

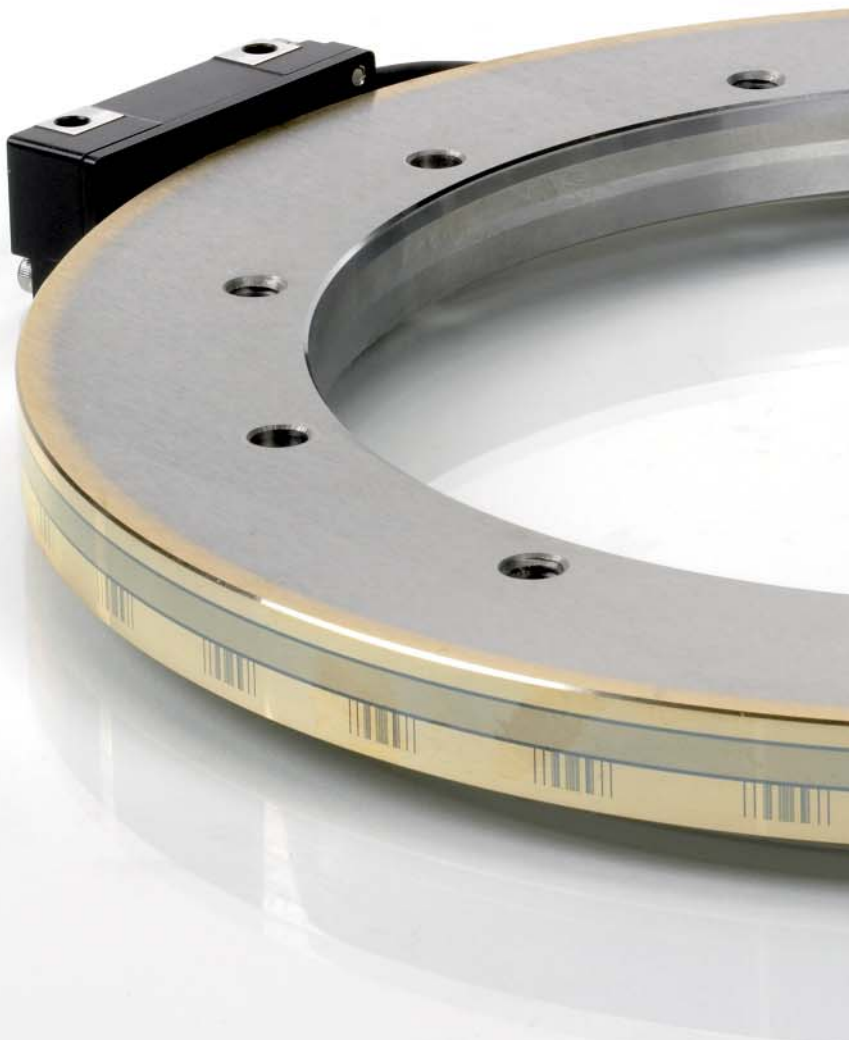

**HEIDENHAIN**



**Angle encoders**  
Without Integral  
Bearing

June 2014

Representante oficial de:



**HEIDENHAIN**

[Argentina – Bolivia – Chile – Colombia - Costa Rica – Ecuador - El Salvador –  
Guatemala – Honduras – Nicaragua – Panamá – Paraguay – Perú -  
República Dominicana – Uruguay – Venezuela.]



Calle 49 N° 5764 - Villa Ballester (B1653AOX) - Prov. de Buenos Aires - ARGENTINA  
Tel: (+54 11) 4768-4242 / Fax: (+54 11) 4849-1212  
Mail: [ventas@nakase.com.ar](mailto:ventas@nakase.com.ar) / Web: [www.nakase.com.ar](http://www.nakase.com.ar)





Information on

- Angle encoders with integral bearing
- Rotary encoders
- Encoders for servo drives
- Exposed linear encoders
- Linear encoders for numerically controlled machine tools
- HEIDENHAIN interface electronics
- HEIDENHAIN controls



is available upon request as well as on the Internet at [www.heidenhain.de](http://www.heidenhain.de).

Comprehensive descriptions of all available interfaces as well as general electrical information are included in the *Interfaces for HEIDENHAIN Encoders* brochure, ID 1078628-xx.

*This catalog supersedes all previous editions, which thereby become invalid. The basis for ordering from HEIDENHAIN is always the catalog edition valid when the contract is made.*

*Standards (ISO, EN, etc.) apply only where explicitly stated in the catalog.*

# Contents

Overview			
	<b>Rotary encoders from HEIDENHAIN</b>		<b>4</b>
<b>Selection guide</b>	Angle encoders and modular encoders without integral bearing		<b>6</b>
	Absolute angle encoders with integral bearing		<b>10</b>
	Incremental angle encoders with integral bearing		<b>12</b>
Technical features and mounting information			
<b>Measuring principles</b>	Measuring standard, incremental measuring principle		<b>14</b>
<b>Scanning the measuring standard</b>			<b>16</b>
<b>Measuring accuracy</b>			<b>18</b>
<b>Reliability</b>			<b>22</b>
<b>Mechanical design types and mounting</b>			<b>24</b>
<b>General mechanical information</b>			<b>32</b>
Specifications	Series or model	Graduation accuracy	
Angle encoders without integral bearing	<b>ERP 880</b>	$\pm 0.9''$	<b>34</b>
	<b>ERP 4080/ERP 8080</b>	To $\pm 1.0''$	<b>36</b>
	<b>ERO 6000 series</b>	To $\pm 2.0''$	<b>38</b>
	<b>ERO 6180</b>	$\pm 10''$	<b>40</b>
	<b>ERA 4000 series</b>	To $\pm 1.7''$	<b>42</b>
	<b>ERA 7000 Series</b>	To $\pm 1.6''$	<b>48</b>
	<b>ERA 8000 series</b>	To $\pm 1.9''$	<b>52</b>
Electrical connection			
<b>Interfaces and pin layouts</b>	Incremental signals	 1 V <sub>PP</sub>	<b>56</b>
		 TTL	<b>57</b>
<b>Cables and connecting elements</b>			<b>58</b>
<b>HEIDENHAIN testing equipment</b>			<b>61</b>
<b>Interface electronics</b>			<b>64</b>
<b>Evaluation electronics units</b>			<b>66</b>

# Rotary encoders from HEIDENHAIN

The term angle encoder is typically used to describe encoders that have an accuracy of better than  $\pm 5''$  and a line count above 10000.

These angle encoders are found in applications that require the **highly accurate measurement of angles** in the range of a few angular seconds, e.g. in rotary tables and swivel heads on machine tools, C axes on lathes, but also in measuring equipment and telescopes.

Other applications, such as scanners, positioning systems, printing units or beam deflection systems, require **high repeatability** and/or a **high angular resolution**. Encoders for such applications are likewise referred to as angle encoders.

In contrast, rotary encoders are used in applications where accuracy requirements are less stringent, e.g. in automation, electrical drives, and many other applications.

The tables on the following pages list different types of angle encoders to suit various applications and meet different requirements.

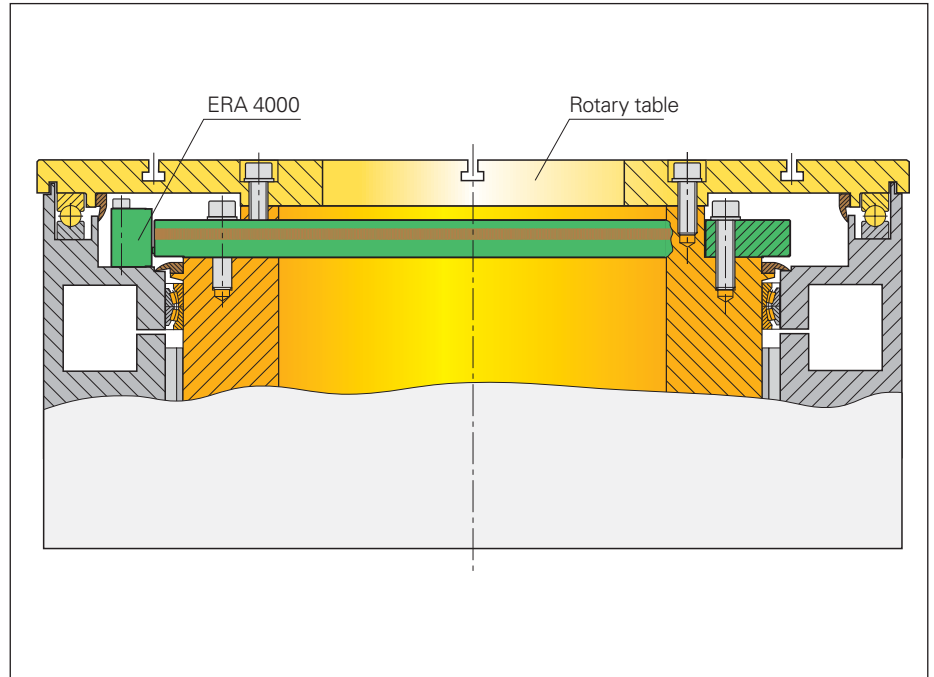

The **ERA 4000** angle encoder mounted onto the rotary table of a machine tool

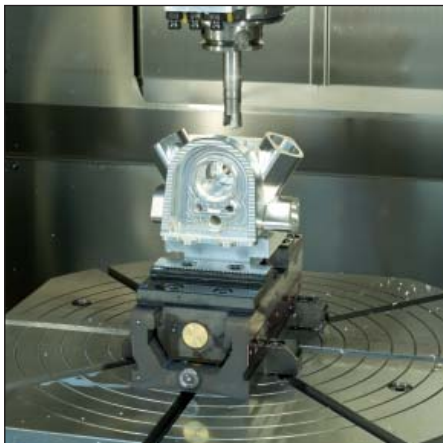

Rotary table on a machine tool

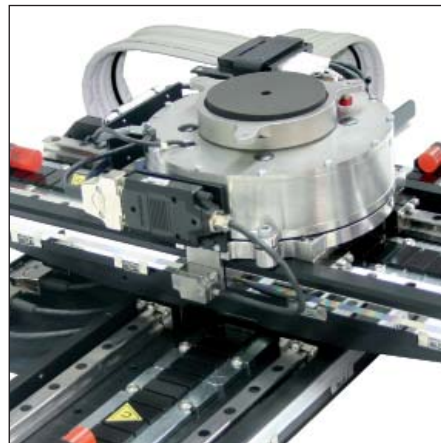

X-Y-theta table

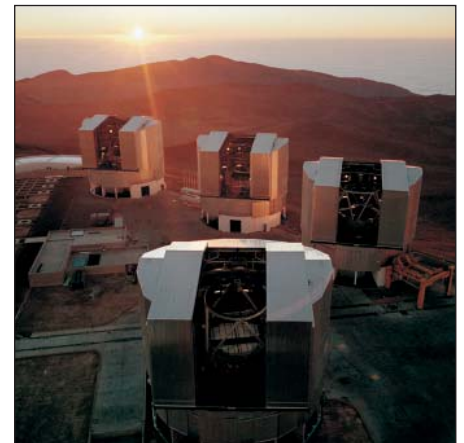

Large telescopes

### Angle encoders without integral bearing

The angle encoders without integral bearing (modular angle encoders) **ERP, ERO** and **ERA** consist of two components—a scanning head and a graduation carrier, which must be aligned with each other during mounting. The eccentricity of the shaft as well as installation and adjustment therefore have a decisive effect on the achievable accuracy.

Modular angle encoders are available with various graduation carriers

- ERP/ERO: Glass circular scale with hub
- ERA 4000: Steel drum
- ERA 7000/8000: Steel tape

Angle encoders without integral bearing are designed for integration in machine elements or components. They are designed to meet the following requirements:

- Large hollow shaft diameters (up to 10 m with a scale tape)
- High shaft speeds
- No additional starting torque from shaft seals
- High reproducibility
- High adaptability to mounting space (versions with scale tape available as full circles or circle segments)

Because angle encoders without integral bearing are supplied without enclosure, the required degree of protection must be ensured through proper installation.

*Selection guide on pages 6 to 9*



### Angle encoders with integral bearing

The angle encoders with integral bearing, **RCN, RON, RPN** and **ROD**, are complete, sealed systems. They are characterized by their simple mounting and uncomplicated adjustment. The integrated stator coupling (with the RCN, RON and RPN) or the separate shaft coupling (with the ROD) compensates axial motion of the measured shaft.

Angle encoders with integrated stator coupling therefore provide excellent dynamic performance because the coupling must absorb only that torque caused by friction in the bearing during angular acceleration of the shaft.

Other advantages:

- Compact size for limited installation space
- Hollow shaft diameters up to 100 mm to provide space for power lines, etc.
- Simple installation
- Large mounting tolerances

*Selection guide on pages 10 to 13*



You can find more detailed information on **angle encoders with integral bearing** on the Internet at [www.heidenhain.de](http://www.heidenhain.de) or in our separate catalog.

# Selection guide

## Angle encoders without integral bearing

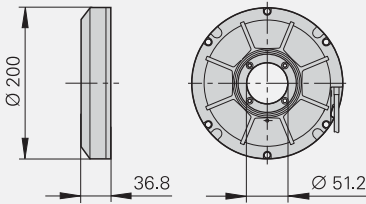
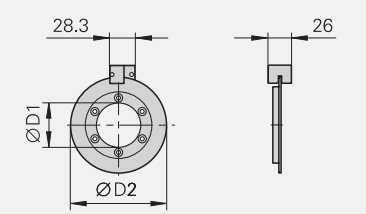
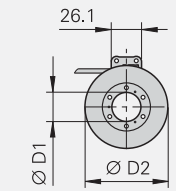
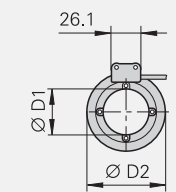
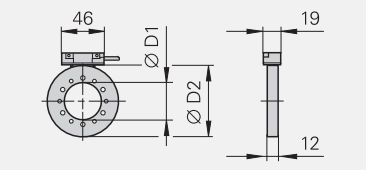
Series	Version and mounting	Overall dimensions in mm	Diameter D1/D2	Accuracy of graduation	Mechanically perm. speed
<b>Angle encoders with graduation on glass disk</b>					
<b>ERP 880</b>	Phase grating on glass disk with hub; screwed onto front of shaft		–	± 0.9"	≤ 1000 min <sup>-1</sup>
<b>ERP 4000</b>	Phase grating on glass disk with hub; screwed onto front of shaft		D1: 8 mm D2: 44 mm	± 2"	≤ 300 min <sup>-1</sup>
<b>ERP 8000</b>			D1: 50 mm D2: 108 mm	± 1"	≤ 100 min <sup>-1</sup>
<b>ERO 6000</b>	METALLUR graduation on glass disk with hub; screwed onto front of shaft		D1: 25/95 mm D2: 71/150 mm	± 5" / ± 3.5"	≤ 1600 min <sup>-1</sup> / ≤ 800 min <sup>-1</sup>
<b>ERO 6100</b>	Chrome graduation on glass; screwed onto front of shaft		D1: 41 mm D2: 70 mm	± 10"	≤ 3500 min <sup>-1</sup>
<b>Angle encoders with graduation on steel scale drum</b>					
<b>ERA 4x80</b>	Scale drum with centering collar; screwed onto front of shaft		D1: 40 mm to 512 mm D2: 76.5 mm to 560.46 mm	± 5" to ± 2"	≤ 10000 min <sup>-1</sup> to ≤ 1500 min <sup>-1</sup>
<b>ERA 4282</b>	Scale drum for increased accuracy; screwed onto front of shaft		D1: 40 mm to 270 mm D2: 76.5 mm to 331.31 mm	± 4" to ± 1.7"	≤ 10000 min <sup>-1</sup> to ≤ 2500 min <sup>-1</sup>

<sup>1)</sup> Through integrate interpolation



	Interface	Signal periods/rev	Reference marks	Type	Page
	~ 1 V <sub>PP</sub>	180 000	One	<b>ERP 880</b>	<b>34</b>
	~ 1 V <sub>PP</sub>	131 072	No	<b>ERP 4080</b>	<b>36</b>
	~ 1 V <sub>PP</sub>	360 000	No	<b>ERP 8080</b>	
	~ 1 V <sub>PP</sub>	9 000/ 18 000	One	<b>ERO 6080</b>	<b>38</b>
	□ TTL	45 000 to 900 000 <sup>1)</sup>	One	<b>ERO 6070</b>	
	~ 1 V <sub>PP</sub>	4 096	One	<b>ERO 6180</b>	<b>40</b>
	~ 1 V <sub>PP</sub>	12 000 to 52 000	Distance- coded	<b>ERA 4280C</b>	<b>42</b>
		6 000 to 44 000		<b>ERA 4480C</b>	
		3 000 to 13 000		<b>ERA 4880C</b>	
	~ 1 V <sub>PP</sub>	12 000 to 52 000	Distance- coded	<b>ERA 4282C</b>	<b>46</b>



ERP 880



ERP 4080



ERO 6080



ERA 4000



# Selection guide

## Angle encoders without integral bearing and modular encoders

Series	Version and mounting	Overall dimensions in mm	Diameter D1/D2	Accuracy of graduation	Mechanically perm. speed
<b>Angle encoders with graduation on steel tape</b>					
<b>ERA 7000</b>	Steel scale tape for internal mounting, full circle version <sup>1)</sup> ; scale tape is tensioned on the inside circumference		458.62 mm to 1146.10 mm	± 3.9" to ± 1.6"	≤ 250 min <sup>-1</sup> to ≤ 220 min <sup>-1</sup>
<b>ERA 8000</b>	Steel scale tape for external mounting, full circle version; scale tape is tensioned on the outside circumference		458.11 mm to 1145.73 mm	± 4.7" to ± 1.9"	Approx. ≤ 45 min <sup>-1</sup>
<b>Modular encoders with magnetic graduation</b>					
<b>ERM 2200</b>	Steel scale drum with MAGNODUR graduation; screwed onto front of shaft		D1: 70 mm to 380 mm D2: 113.16 mm to 452.64 mm	± 7" to ± 2.5"	≤ 14000 min <sup>-1</sup> to ≤ 3000 min <sup>-1</sup>
<b>ERM 200</b>	Steel scale drum with MAGNODUR graduation; screwed onto front of shaft		D1: 40 mm to 410 mm D2: 75.44 mm to 452.64 mm	± 11" to ± 3.5"	≤ 19000 min <sup>-1</sup> to ≤ 3000 min <sup>-1</sup>
<b>ERM 2400</b>	Steel scale drum with MAGNODUR graduation; fastened by clamping		D1: 40/55 mm D2: 64.37/ 75.44 mm	± 17" to ± 9"	≤ 33000 min <sup>-1</sup> to ≤ 27000 min <sup>-1</sup>
<b>ERM 2900</b>			D1: 40 mm to 100 mm D2: 58.6 to 120.96 mm	± 68" to ± 33"	≤ 47000 min <sup>-1</sup> to ≤ 16000 min <sup>-1</sup>

<sup>1)</sup> Segment versions upon request

	Interface	Signal periods/rev	Reference marks	Type	Page
	~ 1 V <sub>PP</sub>	36000 to 90000	Distance-coded	<b>ERA 7480C</b>	<b>48</b>
	~ 1 V <sub>PP</sub>	36000 to 90000	Distance-coded	<b>ERA 8480C</b>	<b>52</b>
	~ 1 V <sub>PP</sub>	1800 to 7200	One	<b>ERM 2280</b>	Catalog: <i>Magnetic Modular Encoders</i>
	□ TTL	600 to 3600	One	<b>ERM 220</b>	
	~ 1 V <sub>PP</sub>			<b>ERM 280</b>	
	~ 1 V <sub>PP</sub>	512 to 600	One	<b>ERM 2485</b>	
	~ 1 V <sub>PP</sub>	192 to 400	One	<b>ERM 2984</b>	



**ERA 7480**



**ERA 8480**



**ERM 2200**



**ERM 280**

# Selection guide

## Absolute angle encoders with integral bearing

Series	Overall dimensions in mm	System accuracy	Mechanically perm. speed	Position values/ Revolution	Interface	
<b>With integrated stator coupling</b>						
<b>RCN 2000</b>		± 5"	≤ 1500 min <sup>-1</sup>	67 108 864 ± 26 bits	EnDat 2.2/02	
		± 2.5"			268 435 456 ± 28 bits	EnDat 2.2/22
						Fanuc 05
		Mit 03-4				
		EnDat 2.2/02				
				EnDat 2.2/22		
Fanuc 05						
Mit 03-4						
<b>RCN 5000</b>		± 5"	≤ 1500 min <sup>-1</sup>	67 108 864 ± 26 bits	EnDat 2.2/02	
		± 2.5"			268 435 456 ± 28 bits	EnDat 2.2/22
						Fanuc 05
		Mit 03-4				
		EnDat 2.2/02				
				EnDat 2.2/22		
Fanuc 05						
Mit 03-4						
<b>RCN 8000</b>	 	± 2"	≤ 500 min <sup>-1</sup>	536 870 912 ± 29 bits	EnDat 2.2/02	
		± 1"			536 870 912 ± 29 bits	EnDat 2.2/22
						Fanuc 05
		Mit 03-4				
		EnDat 2.2/02				
		EnDat 2.2/22				
Fanuc 05						
Mit 03-4						
<b>With mounted stator coupling</b>						
<b>ECN 200</b>		± 10"	≤ 3000 min <sup>-1</sup>	33 554 432 ± 25 bits	EnDat 2.2/02	
					EnDat 2.2/22	
				83 886 08 ± 23 bits	Fanuc 02	
					Mit 02-4	

Incremental signals	Signal periods/ rev	Type	Further Information
~ 1 V <sub>pp</sub>	16384	<b>RCN 2380</b>	Catalog Angle encoders with integral bearing
-	-	<b>RCN 2310</b>	
-	-	<b>RCN 2390F</b>	
-	-	<b>RCN 2390M</b>	
~ 1 V <sub>pp</sub>	16384	<b>RCN 2580</b>	
-	-	<b>RCN 2510</b>	
-	-	<b>RCN 2590F</b>	
-	-	<b>RCN 2590M</b>	
~ 1 V <sub>pp</sub>	32768	<b>RCN 5380</b>	
-	-	<b>RCN 5310</b>	
-	-	<b>RCN 5390F</b>	
-	-	<b>RCN 5390M</b>	
~ 1 V <sub>pp</sub>	32768	<b>RCN 5580</b>	
-	-	<b>RCN 5510</b>	
-	-	<b>RCN 5590F</b>	
-	-	<b>RCN 5590M</b>	
~ 1 V <sub>pp</sub>	32768	<b>RCN 8380</b>	
-	-	<b>RCN 8310</b>	
-	-	<b>RCN 8390F</b>	
-	-	<b>RCN 8390M</b>	
~ 1 V <sub>pp</sub>	32768	<b>RCN 8580</b>	
-	-	<b>RCN 8510</b>	
-	-	<b>RCN 8590F</b>	
-	-	<b>RCN 8590M</b>	
~ 1 V <sub>pp</sub>	2048	<b>ECN 225</b>	Catalog Angle encoders with integral bearing
-	-	<b>ECN 225</b>	
-	-	<b>ECN 223F</b>	
-	-	<b>ECN 223M</b>	



RCN 2000



RCN 5000



RCN 8000  
Ø 60 mm



RCN 8000  
Ø 100 mm



ECN 200  
Ø 50 mm

# Selection guide

## Incremental angle encoders with integral bearing

Series	Overall dimensions in mm	System accuracy	Mechanically perm. speed	Interface
<b>With integrated stator coupling</b>				
<b>RON 200</b>		$\pm 5''$	$\leq 3000 \text{ min}^{-1}$	$\square$ TTL
		$\pm 2.5''$		$\square$ TTL
<b>RON 700</b>		$\pm 2''$	$\leq 1000 \text{ min}^{-1}$	$\sim 1 V_{PP}$
				$\sim 1 V_{PP}$
<b>RON 800 RPN 800</b>		$\pm 1''$	$\leq 1000 \text{ min}^{-1}$	$\sim 1 V_{PP}$
<b>RON 900</b>		$\pm 0.4''$	$\leq 100 \text{ min}^{-1}$	$\sim 11 \mu A_{PP}$
<b>For separate shaft coupling</b>				
<b>ROD 200</b>		$\pm 5''$	$\leq 10000 \text{ min}^{-1}$	$\square$ TTL
<b>ROD 700</b>		$\pm 2''$	$\leq 1000 \text{ min}^{-1}$	$\sim 1 V_{PP}$
<b>ROD 800</b>		$\pm 1''$	$\leq 1000 \text{ min}^{-1}$	$\sim 1 V_{PP}$

<sup>1)</sup> After integrated interpolation

	Signal periods/rev	Type	Further Information
	18000 <sup>1)</sup>	<b>RON 225</b>	Catalog Angle encoders with integral bearing
	180000/90000 <sup>1)</sup>	<b>RON 275</b>	
	18000	<b>RON 285</b>	
	18000	<b>RON 287</b>	
	18000	<b>RON 785</b>	
	18000/36000	<b>RON 786</b>	
	36000	<b>RON 886</b>	
	180000	<b>RPN 886</b>	
	36000	<b>RON 905</b>	
	18000 <sup>1)</sup>	<b>ROD 220</b>	Catalog Angle encoders with integral bearing
	180000 <sup>1)</sup>	<b>ROD 270</b>	
	18000	<b>ROD 280</b>	
	18000/36000	<b>ROD 780</b>	
	36000	<b>ROD 880</b>	



**RON 285**



**RON 786**



**RON 905**



**ROD 280**



**ROD 780**

# Measuring principles

## Measuring standard

HEIDENHAIN encoders incorporate measuring standards of periodic structures known as graduations.

These graduations are applied to a glass or steel substrate. Glass scales are used primarily in encoders for speeds up to  $10\,000\text{ min}^{-1}$ . Steel drums are used for higher speeds—up to  $20\,000\text{ min}^{-1}$ . The scale substrate for large diameters is a steel tape.

HEIDENHAIN manufactures the precision graduations in specially developed, photolithographic processes.

- AURODUR: matte-etched lines on gold-plated steel tape with typical graduation period of  $40\text{ }\mu\text{m}$
- METALLUR: contamination-tolerant graduation of metal lines on gold, with typical graduation period of  $20\text{ }\mu\text{m}$
- DIADUR: extremely robust chromium lines on glass (typical graduation period of  $20\text{ }\mu\text{m}$ ) or three-dimensional chromium structures (typical graduation period of  $8\text{ }\mu\text{m}$ ) on glass
- SUPRADUR phase grating: optically three dimensional, planar structure; particularly tolerant to contamination; typical graduation period of  $8\text{ }\mu\text{m}$  and finer
- OPTODUR phase grating: optically three dimensional, planar structure with particularly high reflectance, typical graduation period of  $2\text{ }\mu\text{m}$  and finer

These processes permit very fine grating periods and are characterized by a high definition and homogeneity of the line edges. Together with the photoelectric scanning method, this high edge definition is a precondition for the high quality of the output signals.

The master graduations are manufactured by HEIDENHAIN on custom-built high-precision dividing engines.

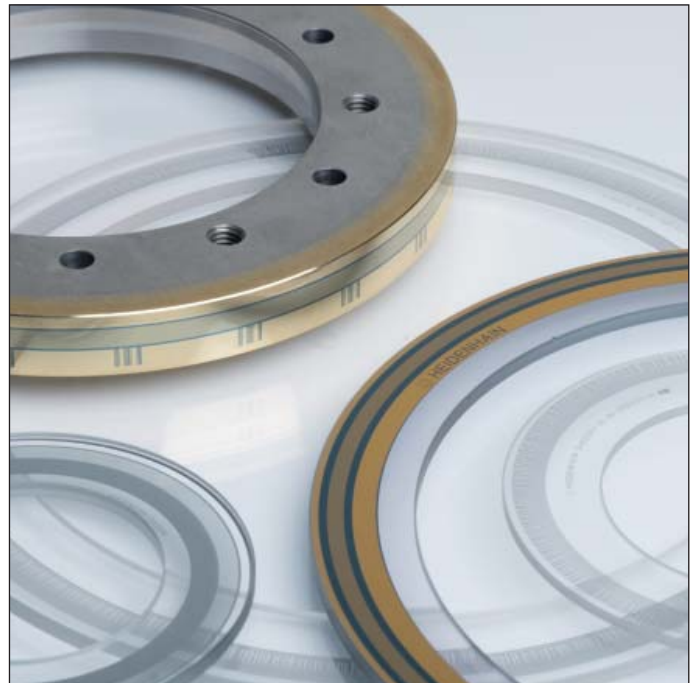

Circular graduations of angle encoders



# Incremental measuring method

With the **incremental measuring method**, the graduation consists of a periodic grating structure. The position information is obtained **by counting** the individual increments (measuring steps) from some point of origin. Since an absolute reference is required to ascertain positions, the measuring standard is provided with an additional track that bears a **reference mark**. The absolute position on the scale, established by the reference mark, is gated with exactly one measuring step.

The reference mark must therefore be scanned to establish an absolute reference or to find the last selected datum.

In some cases, this may require rotation by up to nearly 360°. To speed and simplify such "reference runs," many HEIDENHAIN encoders feature **distance-coded reference marks**—multiple reference marks that are individually spaced according to a mathematical algorithm. The subsequent electronics find the absolute reference after traversing two successive reference marks—meaning only a few degrees of traverse (see nominal increment I in the table).

Encoders with distance-coded reference marks are identified by a "C" behind the model designation (e.g. ERA 4200 C).

With distance-coded reference marks, the **absolute reference** is calculated by counting the signal periods between two reference marks and using the following formulas:

$$\alpha_1 = (\text{abs } A - \text{sgn } A - 1) \times \frac{I}{2} + (\text{sgn } A - \text{sgn } D) \times \frac{\text{abs } M_{RR}}{2}$$

where:

$$A = \frac{2 \times \text{abs } M_{RR} - I}{GP}$$

Where:

$\alpha_1$  = Absolute angular position of the first traversed reference mark to the zero position in degrees

abs = Absolute value

sgn = Sign function (" +1 " or " -1 ")

$M_{RR}$  = Measured distance between the traversed reference marks in degrees

I = Nominal increment between two fixed reference marks (see tables)

GP = Grating period ( $\frac{360^\circ}{\text{Line count}}$ )

D = Direction of rotation (+1 or -1)  
Rotation as per mating dimensions equals +1

## ERA 7480C, ERA 8480C

Line count z	Number of reference marks	Nominal increment I
36000	72	10°
45000	90	8°
90000	180	4°

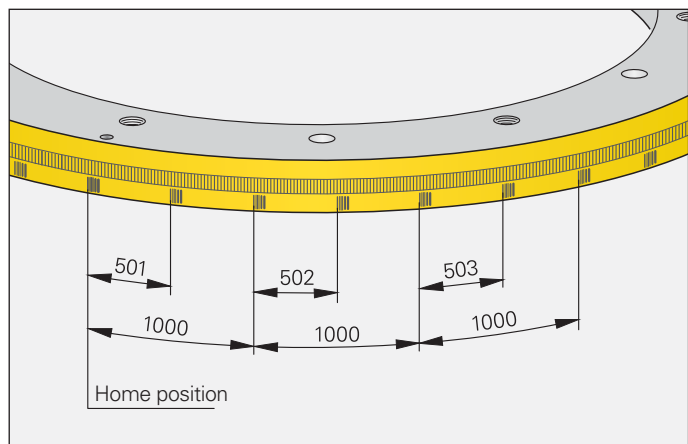

Schematic representation of a circular graduation with distance-coded reference marks (ERA 4480 with 20 000 lines as example)

## ERA 4000C

Line count for grating period			Number of reference marks	Nominal increment I
20 µm	40 µm	80 µm		
–	–	3000	6	120°
8192	4096	4096	8	90°
–	–	5000	10	72°
12000	6000	–	12	60°
–	–	7000	14	51.429°
16384	8192	8192	16	45°
20000	10000	10000	20	36°
24000	12000	12000	24	30°
–	–	13000	26	27.692°
28000	14000	–	28	25.714°
32768	16384	–	32	22.5°
40000	20000	–	40	18°
48000	24000	–	48	15°
52000	26000	–	52	13.846°
–	38000	–	76	9.474°
–	44000	–	88	8.182°

# Scanning the measuring standard

## Photoelectric scanning

Most HEIDENHAIN encoders operate using the principle of photoelectric scanning. Photoelectric scanning of a measuring standard is contact-free, and as such, free of wear. This method detects even very fine lines, no more than a few microns wide, and generates output signals with very small signal periods.

The finer the grating period of a measuring standard is, the greater the effect of diffraction on photoelectric scanning. HEIDENHAIN uses two scanning principles with angle encoders:

- The **imaging scanning principle** for grating periods from 10  $\mu\text{m}$  to approx. 70  $\mu\text{m}$ .
- The **interferential scanning principle** for very fine graduations with grating periods of 4  $\mu\text{m}$  and finer.

### Imaging principle

Put simply, the imaging scanning principle functions by means of projected-light signal generation: two graduations with equal grating periods—the circular scale and the scanning reticle—are moved relative to each other. The carrier material of the scanning reticle is transparent, whereas the graduation on the measuring standard may be applied to a transparent or reflective surface.

When parallel light passes through a grating, light and dark surfaces are projected at a certain distance. An index grating with the same grating period is located here. When the two gratings move relative to each other, the incident light is modulated. If the gaps in the gratings are aligned, light passes through. If the lines of one grating coincide with the gaps of the other, no light passes through.

Photovoltaic cells convert these variations in light intensity into electrical signals. The specially structured grating of the scanning reticle filters the light to generate nearly sinusoidal output signals. The smaller the period of the grating structure is, the closer and more tightly tolerated the gap must be between the scanning reticle and circular scale. Practical mounting tolerances for encoders with the imaging scanning principle are achieved with grating periods of 10  $\mu\text{m}$  and larger.

The ERA angle encoders, for example, operate according to the imaging scanning principle.

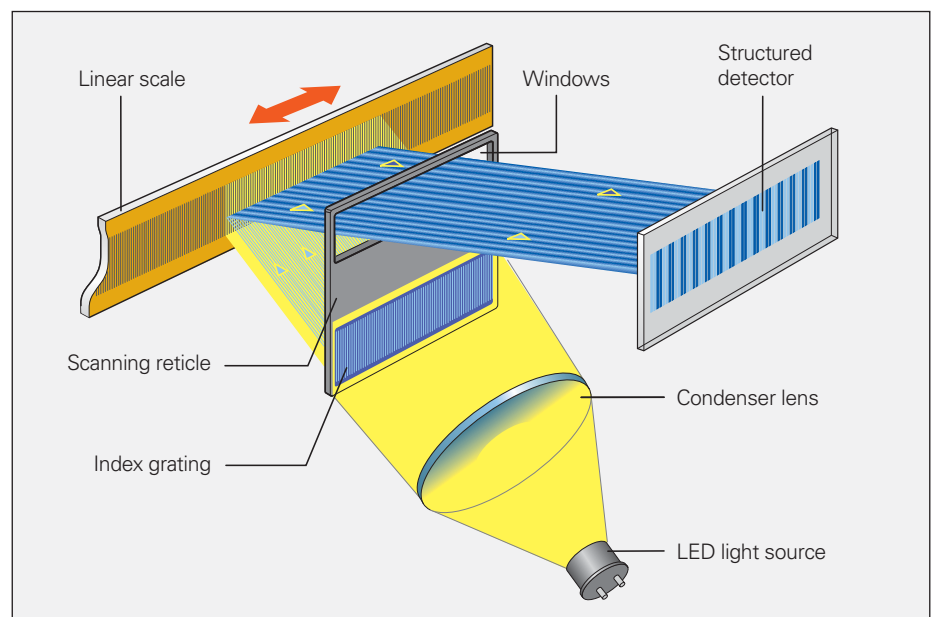
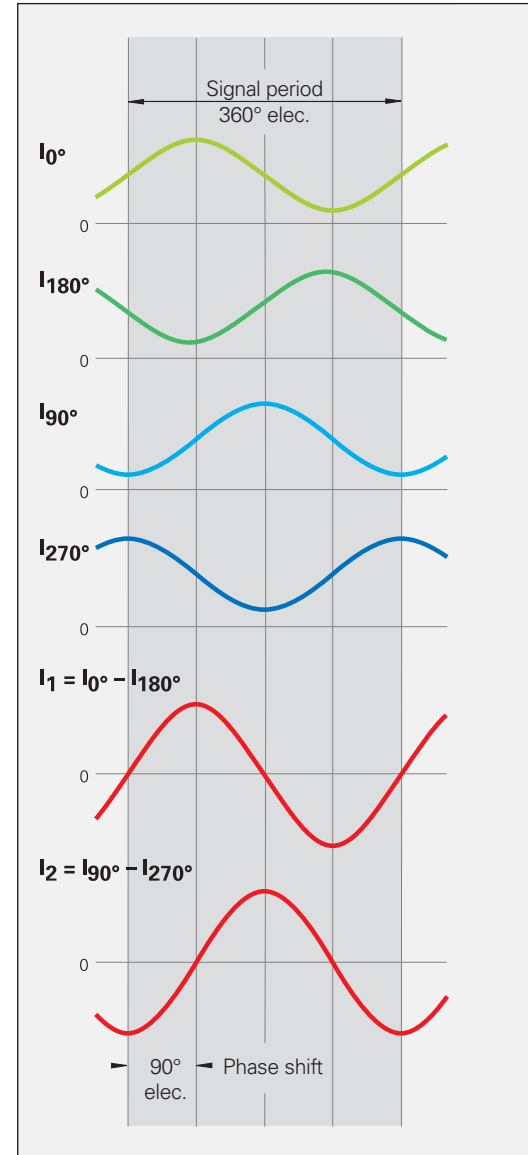

Photoelectric scanning in accordance with the imaging principle with a steel scale and single-field scanning

The sensor generates four nearly sinusoidal current signals ( $I_{0^\circ}$ ,  $I_{90^\circ}$ ,  $I_{180^\circ}$  and  $I_{270^\circ}$ ), electrically phase-shifted to each other by  $90^\circ$ . These scanning signals do not at first lie symmetrically about the zero line. For this reason the photovoltaic cells are connected in a push-pull circuit, producing two  $90^\circ$  phase-shifted output signals  $I_1$  and  $I_2$  in symmetry with respect to the zero line.

In the XY representation on an oscilloscope, the signals form a Lissajous figure. Ideal output signals appear as a centered circle. Deviations in the circular form and position are caused by position error within one signal period (see *Measuring Accuracy*) and therefore go directly into the result of measurement. The size of the circle, which corresponds to the amplitude of the output signal, can vary within certain limits without influencing the measuring accuracy.

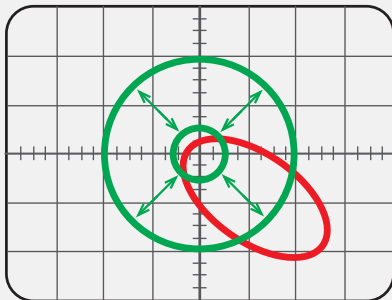

XY representation of the output signals

### Interferential scanning principle

The interferential scanning principle exploits the diffraction and interference of light on a fine graduation to produce signals used to measure displacement. A step grating is used as the measuring standard: reflective lines  $0.2 \mu\text{m}$  high are applied to a flat, reflective surface. In front of that is the scanning reticle—a transparent phase grating with the same grating period as the scale.

When a light wave passes through the scanning reticle, it is diffracted into three partial waves of the orders  $-1$ ,  $0$ , and  $+1$ , with approximately equal luminous intensity. The waves are diffracted by the scale such that most of the luminous intensity is found in the reflected diffraction orders  $+1$  and  $-1$ . These partial waves meet again at the phase grating of the scanning reticle where they are diffracted again and interfere. This produces essentially three waves that leave the scanning reticle at different angles. Photovoltaic cells convert this alternating light intensity into electrical signals.

A relative motion of the scanning reticle to the scale causes the diffracted wave fronts to undergo a phase shift: when the grating moves by one period, the wave front of the first order is displaced by one wavelength in the positive direction, and the wavelength of diffraction order  $-1$  is displaced by one wavelength in the negative direction. Since the two waves interfere with each other when exiting the grating, the waves are shifted relative to each other by two wavelengths. This results in two signal periods from the relative motion of just one grating period.

Interferential encoders function with average grating periods of  $4 \mu\text{m}$  and finer. Their scanning signals are largely free of harmonics and can be highly interpolated. These encoders are therefore especially suited for high resolution and high accuracy. Even so, their generous mounting tolerances permit installation in a wide range of applications.

The ERP angle encoders, for example, operate according to the interferential scanning principle.

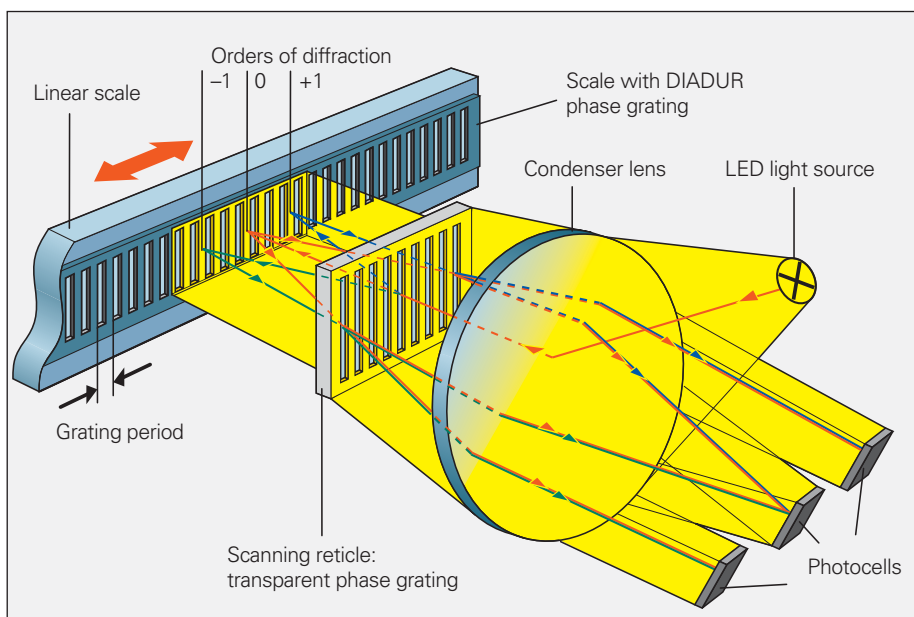

Photoelectric scanning according to the interferential principle and single-field scanning

# Measuring accuracy

The accuracy of angular measurement is mainly determined by

- the quality of the graduation,
- the stability of the graduation carrier,
- the quality of the scanning process,
- the quality of the signal processing electronics,
- the eccentricity of the graduation to the bearing,
- the error of the bearing,
- the coupling to the measured shaft.

These factors of influence are comprised of encoder-specific error and application-dependent issues. All individual factors of influence must be considered in order to assess the attainable total accuracy.

## Encoder-specific error

The encoder-specific error is given in the Specifications:

- Accuracy of graduation
- Position error within one signal period

## Accuracy of graduation

The accuracy of the graduation  $\pm a$  results from its quality. This includes

- the homogeneity and period definition of the graduation,
- the alignment of the graduation on its carrier,
- for encoders with massive graduation carriers: the stability of the graduation carrier, in order to also ensure accuracy in the mounted condition,
- for encoders with steel scale tape: the error due to irregular scale-tape expansion during mounting, as well as the error at the scale-tape butt joints of full-circle applications.

*The accuracy of the graduation  $\pm a$  is ascertained under ideal conditions by using a series-produced scanning head to measure position error at positions that are integral multiples of the signal period.*

## Position error within one signal period

The position error within one signal period  $\pm u$  results from the quality of the scanning and—for encoders with integrated pulse-shaping or counter electronics—the quality of the signal-processing electronics. For encoders with sinusoidal output signals, however, the errors are determined by the signal processing electronics of the subsequent electronics.

The following individual factors influence the result:

- The length of the signal period
- The homogeneity and period definition of the graduation
- The quality of scanning filter structures
- The characteristics of the detectors
- The stability and dynamics of further processing of the analog signals

These factors of influence are to be considered when specifying position error within one signal period.

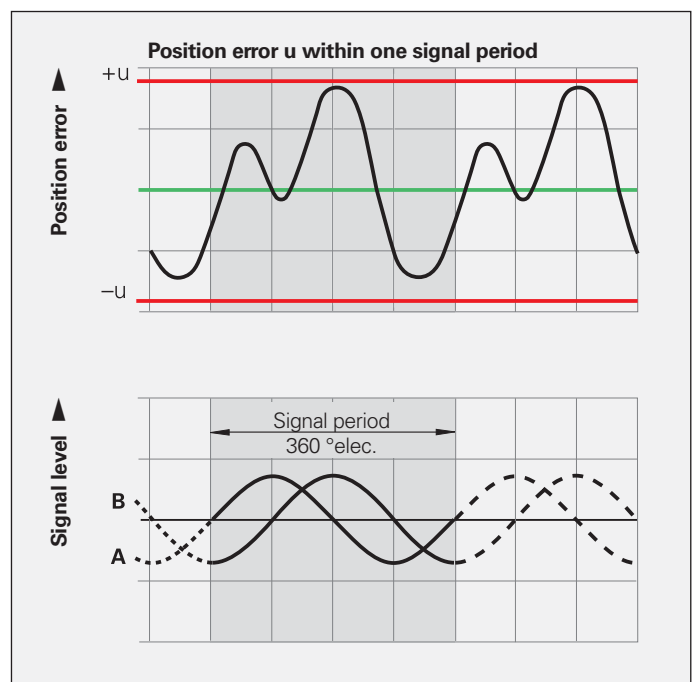
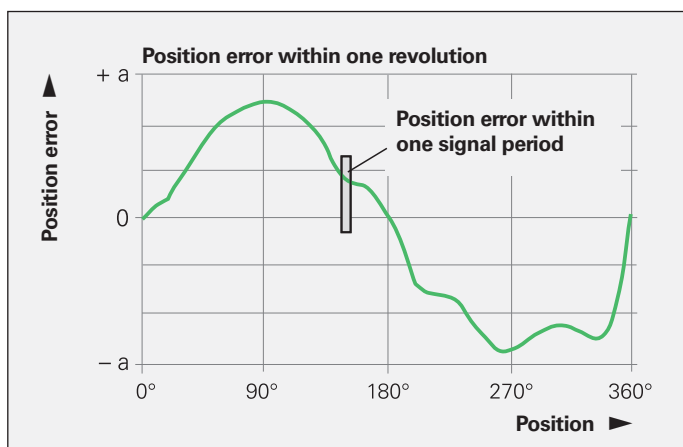

Position error within one signal period  $\pm u$  is specified in percent of the signal period. For modular angle encoders without integral bearing the value is typically better than  $\pm 1\%$  of the signal period (ERP 880:  $\pm 1.5\%$ ). You will find the specified values in the Specifications.

Position errors within one signal period already become apparent in very small angular motions and in repeated measurements. They especially lead to speed ripples in the speed control loop.

### Application-dependent error

The mounting and adjustment of the scanning head, in addition to the given encoder-specific error, normally have a significant effect on the accuracy that can be achieved by **encoders without integral bearings**. Of particular importance are the mounting eccentricity of the graduation and the radial runout of the measured shaft. The application-dependent error values must be measured and calculated individually in order to evaluate the total accuracy.

In contrast, the specified system accuracy for encoders with integral bearing already includes the error of the bearing and the shaft coupling (see catalog *Angle Encoders with Integral Bearing*).

### Errors due to eccentricity of the graduation to the bearing

Under normal circumstances, the graduation will have a certain eccentricity relative to the bearing once the disk/hub assembly, scale drum or steel scale tape is mounted. In addition, dimensional and form deviations of the customer's shaft can result in added eccentricity. The following relationship exists between the eccentricity  $e$ , the graduation diameter  $D$  and the measuring error  $\Delta\varphi$  (see illustration below):

$$\Delta\varphi = \pm 412 \cdot \frac{e}{D}$$

$\Delta\varphi$  = Measurement error in " (angular seconds)

$e$  = Eccentricity of the scale drum to the bearing in  $\mu\text{m}$  (1/2 the radial deviation)

$D$  = Mean graduation diameter in mm

$M$  = Center of graduation

$\varphi$  = "True" angle

$\varphi'$  = Scanned angle

Encoder-specific error of ERA 7000 and ERA 8000

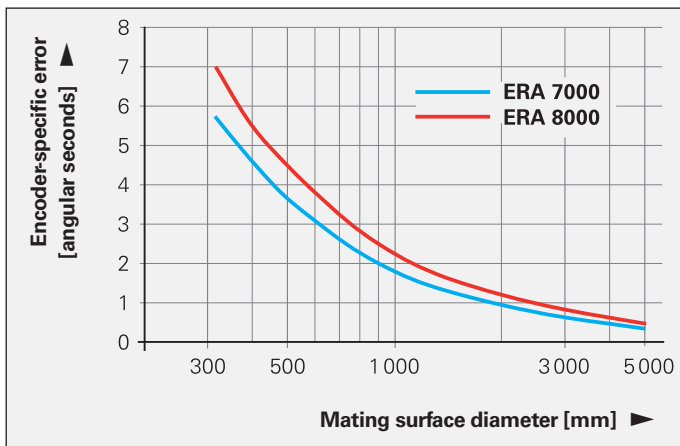

### Mean graduation centerline diameter D for:

ERP 880	D = 126 mm
ERP 4000	D = 40 mm
ERP 8000	D = 104 mm
ERO 6000	D = 64 mm or 142 mm
ERO 6100	D = 64 mm
ERA 4000	D $\hat{=}$ Drum outside diameter
ERA 7000	D $\hat{=}$ Scale mating diameter
ERA 8000	

Eccentricity of the graduation to the bearing

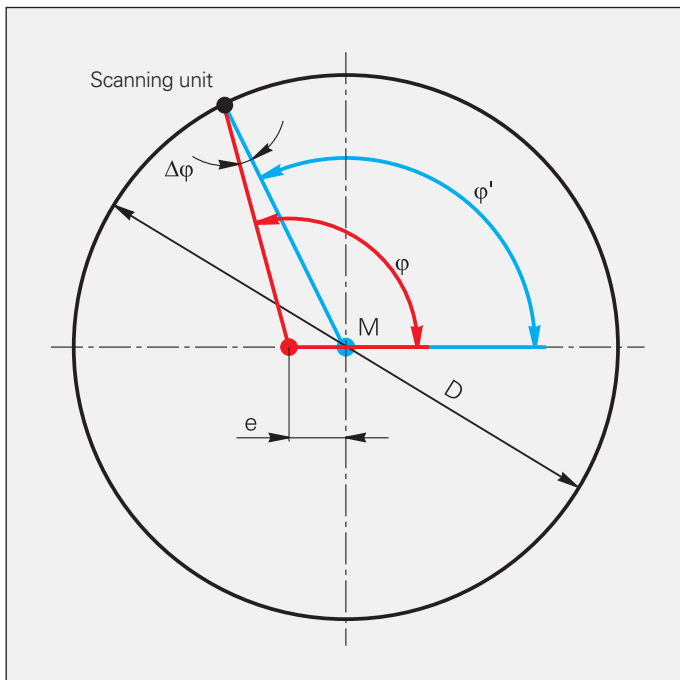

Resultant measuring error  $\Delta\varphi$  for various eccentricity values  $e$  as a function of mean graduation diameter  $D$

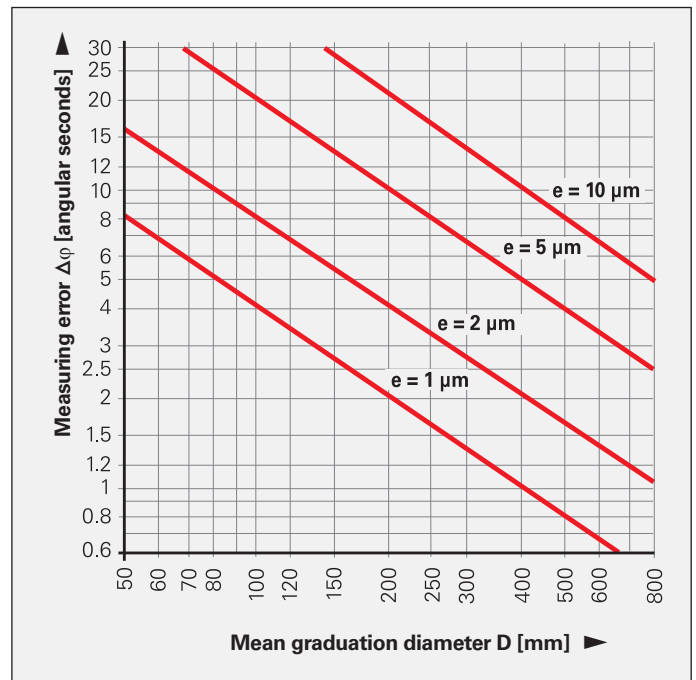

**Error due to radial runout of the bearing**

The equation for the measuring error  $\Delta\phi$  is also valid for radial error of the bearing if the value  $e$  is replaced with the eccentricity value, i.e. half of the radial error (half of the displayed value). Bearing compliance to radial shaft loading causes similar errors.

**Deformation of the graduation resulting from mounting**

The profile, reference surfaces, position of the graduation relative to the mounting surface, mounting holes, etc. of the scale drums and disk/hub assemblies are all designed so that the mounting and operation only marginally influence the accuracy of the encoders.

**Shape and diameter error of the bearing surface (for ERA 7000 and ERA 8000)**

Shape errors of the bearing surface can impair the attainable system accuracy.

In the segment solutions, the additional angular error  $\Delta\phi$  occurs when the nominal scale-tape bearing-surface diameter is not exactly maintained:

$$\Delta\phi = (1 - \phi \cdot 3600)$$

where

$\Delta\phi$  = Segment deviation in angular seconds

$\phi$  = Segment angle in degrees

$D$  = Nominal scale-tape carrier diameter

$D'$  = Actual scale-tape carrier diameter

This error can be eliminated if the line count per  $360^\circ$   $z'$  valid for the actual scale-tape carrier diameter  $D'$  can be entered in the control. The following relationship is valid:

$$z' = z \cdot D'/D$$

where  $z$  = Nominal line count per  $360^\circ$

$z'$  = Actual line count per  $360^\circ$

The angle actually traversed in segment versions should be measured with a comparative encoder, such as an angle encoder with integral bearing.

**Compensation possibilities**

The mounting eccentricity of the graduation and the radial runout of the measured shaft cause a large share of the application-dependent errors. A common and effective method of eliminating these errors is to mount two or even more scanning heads at equal distances around the graduation carrier. The subsequent electronics mathematically combine the individual position values.

The EIB 1500 from HEIDENHAIN is an electronics unit suitable for mathematically combining the position values from two scanning heads in real time, without impairing the control loop (see *Evaluation and display units*).

The accuracy improvement actually attained by this in practice strongly depends on the installation situation and the application. In principle, all eccentricity errors (reproducible errors due to mounting errors, non-reproducible errors due to radial eccentricity of the bearing) as well as all uneven harmonics of the graduation error are eliminated.

Angular error due to variations in scale-tape carrier diameter

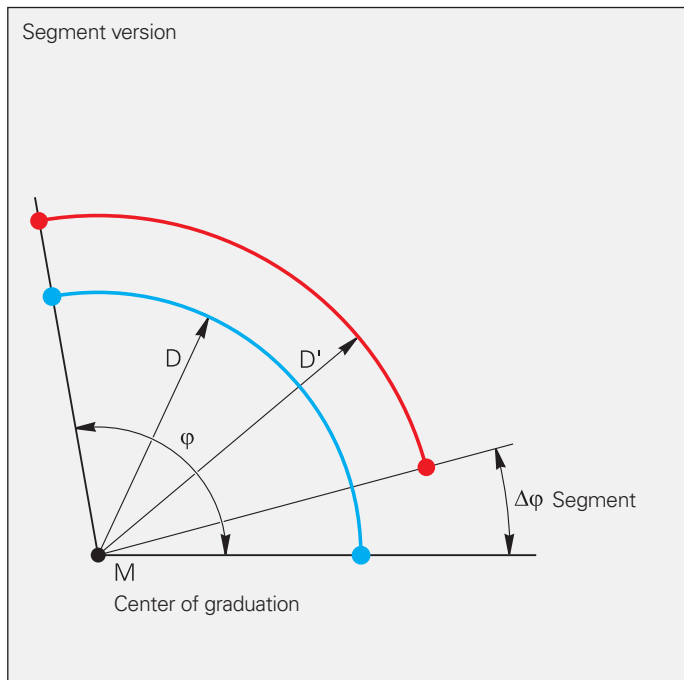

Position calculation of two scanning heads in order to compensate for eccentricity and radial runout

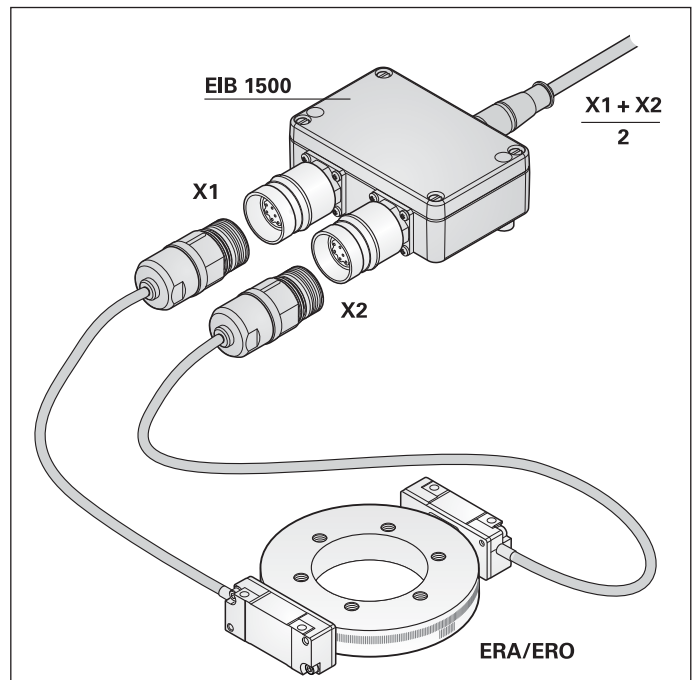



# Calibration chart

For its ERP, ERO and ERA 4000 angle encoders, HEIDENHAIN prepares individual calibration charts and ships them with the encoder.

The **calibration chart** documents the graduation accuracy including the graduation carrier. It is ascertained through a large number of measuring points during one revolution. All measured values lie within the graduation accuracy listed in the specifications.

The deviations are ascertained at constant temperatures (22 °C) during the final inspection and are indicated on the calibration chart.

The **calibration standard** indicated in the manufacturer's inspection certificate documents and guarantees traceability to recognized national and international standards.

The accuracy data of the calibration chart do not include the position error within one signal period and any error resulting from mounting.

For testing and calibration purposes, angle encoders without integral bearing with massive graduation carriers are mounted at HEIDENHAIN exactly the same way as in the application later. This ensures that it is possible to apply the accuracy determined at HEIDENHAIN exactly to the machine.

## Calibration chart example: ERA 4200 C scale drum

- 1 Graphic representation of the graduation error
- 2 Result of calibration

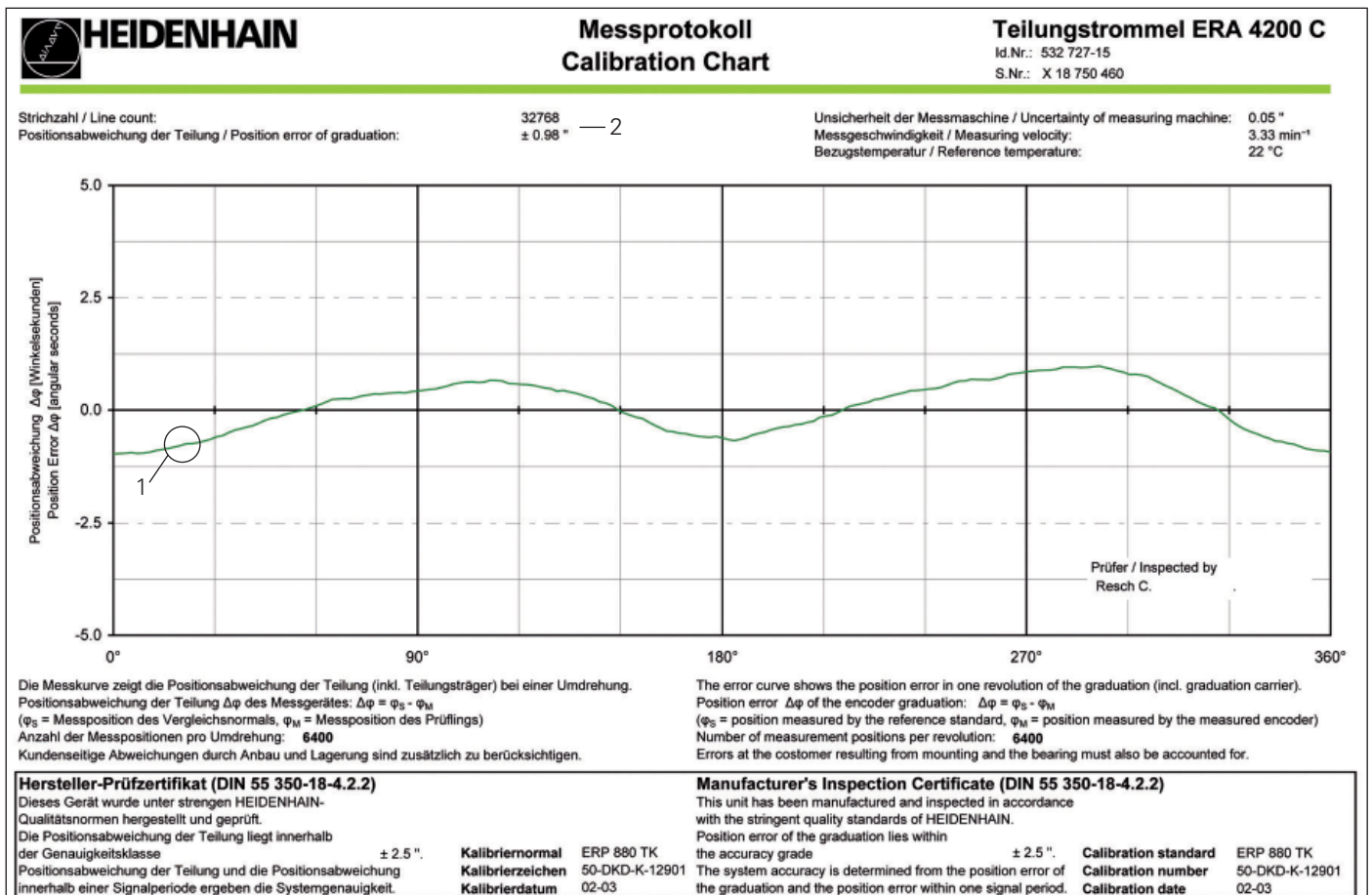



# Reliability

Exposed angle encoders without integral bearing from HEIDENHAIN are optimized for use on fast, precise machines. In spite of the exposed mechanical design, they are highly tolerant to contamination, ensure high long-term stability, and are quickly and easily mounted.

## Lower sensitivity to contamination

Both the high quality of the grating and the scanning method are responsible for the accuracy and reliability of the encoders. Encoders from HEIDENHAIN operate with **single-field scanning**. Only one scanning field is used to generate the scanning signals. Local contamination on the measuring standard (e.g. fingerprints or oil accumulation) influences the light intensity of the signal components, and therefore of the scanning signals, in equal measure. The output signals do change in their amplitude, but not in their offset and phase position. They remain highly interpolable, and the position error within one signal period remains small.

The **large scanning field** additionally reduces sensitivity to contamination. In many cases this can prevent encoder failure. Even if the contamination from printer's ink, PCB dust, water or oil is up to 3 mm in diameter, the encoders continue to provide high-quality signals. The position errors within one revolution remain far below the specified accuracy.

The figures at right show the results of contamination tests with ERA 4000 encoders. The maximum position errors within one signal period  $|u|$  are indicated. Despite significant contamination, the specified value of  $\pm 1\%$  is exceeded only slightly.

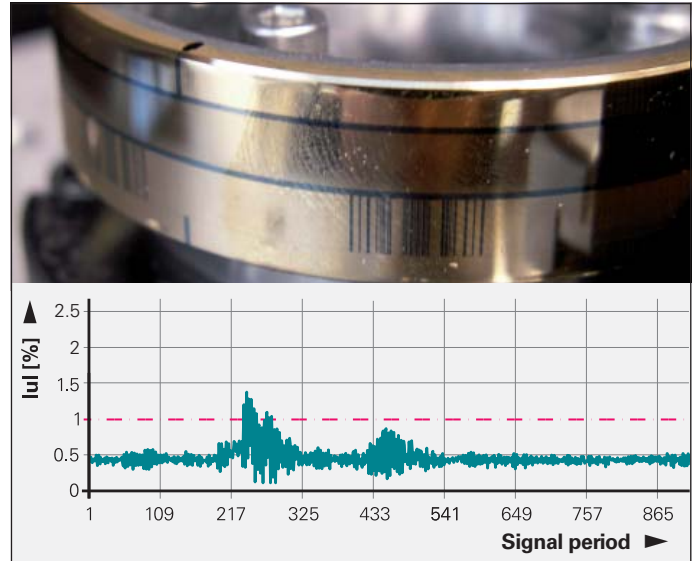

Contamination by fingerprint

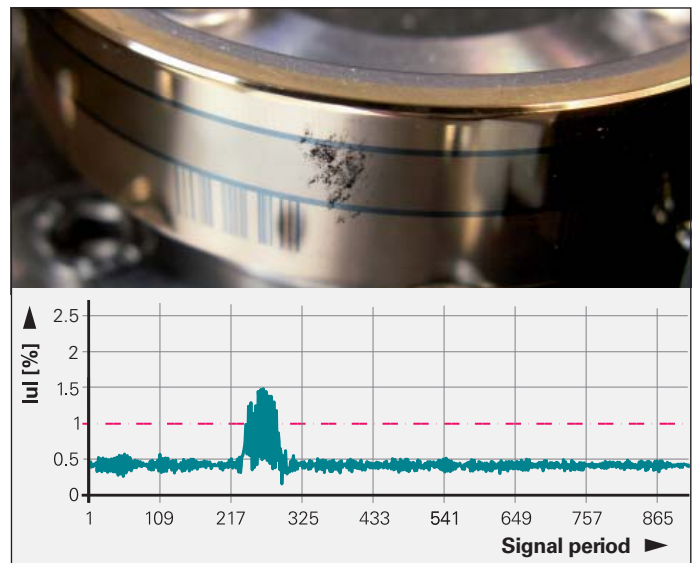

Contamination by toner dust

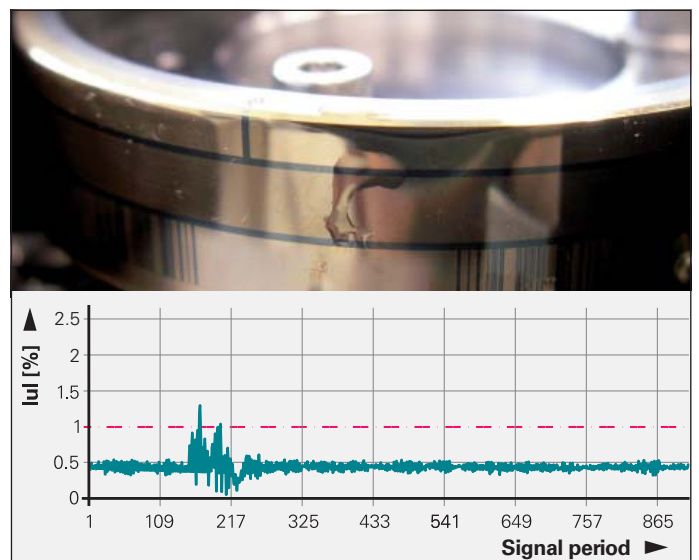

Contamination by water drops

### Durable measuring standards

By the nature of their exposed design, the measuring standards of angle encoders without integral bearing are less protected from their environment. HEIDENHAIN therefore always uses tough gratings manufactured in special processes.

In the DIADUR process, hard chrome structures are applied to a glass or steel carrier.

In the METALLUR process a reflective gold layer is covered with a thin layer of glass. On this layer are lines of chromium only several nanometers thick, which are semitransparent and act as absorbers. Measuring standards with METALLUR graduations have proven to be particularly robust and insensitive to contamination because the low height of the structure leaves practically no surface for dust, dirt or water particles to accumulate.

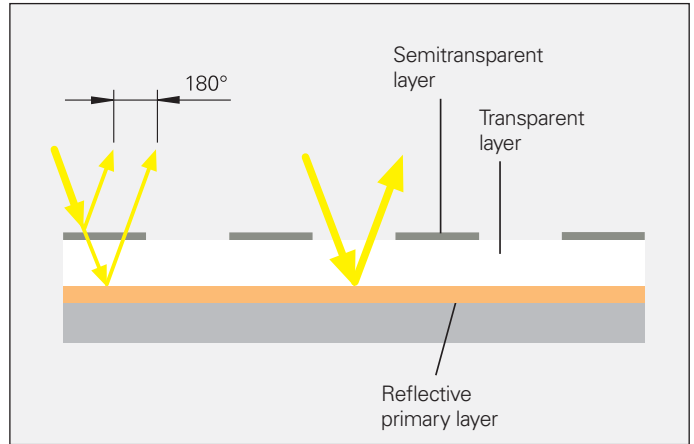

Composition of a METALLUR graduation

### Application-oriented mounting tolerances

The mounting tolerances of angle encoders without integral bearing from HEIDENHAIN have only a slight influence on the output signals. In particular, a variation in the scanning gap between the graduation carrier and scanning head causes only negligible change in the signal amplitude, and barely affect the position error within one signal period. This behavior is substantially responsible for the high reliability of angle encoders from HEIDENHAIN.

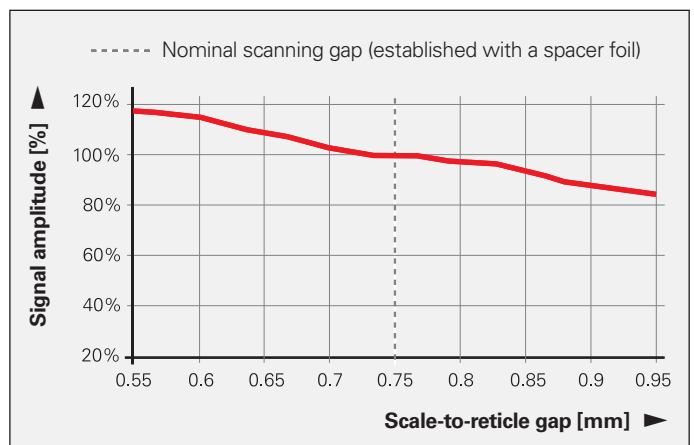

Influence of the scanning gap on the signal amplitude for ERA 4000

# Mechanical design types and mounting

## General information

Angle encoders without integral bearing consist of a scanning head and a graduation carrier. The graduation carrier can either be a scale tape or a massive component, such as a scale drum or disk/hub assembly. The motion of the scanning head and graduation relative to each other is determined solely via the machine bearing. For this reason the machine must be designed from the very beginning to meet the following prerequisites:

- The **bearing** must be so designed that the mounting tolerances of the encoders are maintained and the accuracy requirements expected for the axis are fulfilled (see *Specifications*) during mounting as well as operation.
- The **mounting surface** for the graduation carrier must meet the demands of the respective encoder regarding flatness, roundness, eccentricity and the diameter.
- To facilitate **adjustment** of the scanning head to the graduation, the scanning head should be fastened to a bracket or by using appropriate fixed stops.

All angle encoders without integral bearing with **massive graduation carriers** are designed so that the specified accuracy can actually be achieved in the application. The mounting methods and alignment strategies ensure the highest possible reproducibility.

### Centering the graduation

Since graduations from HEIDENHAIN have a very high degree of accuracy, the attainable overall accuracy is predominantly affected by mounting errors (mainly eccentricity errors). Various possibilities for centering, depending on the encoder and mounting method, are possible for minimizing the eccentricity errors in practice.

#### 1. Centering collar

The graduation carrier is pushed or shrunk onto the shaft. However, this very simple strategy requires a very exact shaft geometry.

#### 2. Three-point centering

The graduation carrier is centered over three positions at 120° increments marked on the carrier. That way, any roundness errors of the surface on which the carrier is being centered do not affect the exact alignment of the axis center point.

#### 3. Optical centering

Graduation carriers made from glass are often centered with the aid of a microscope. This method uses the clear and unambiguous reference edges or centering rings on the graduation carriers.

#### 4. Centering with two scanning heads

This strategy is suited for all angle encoders without integral bearing with massive graduation carriers. Since HEIDENHAIN graduations typically have long-range error characteristics, and the graduation or position value itself is used as reference here, this is the most exact of all centering strategies.

### Scanning heads

Since final assembly of the angle encoders without integral bearing takes place on the machine, exact mounting of the scanning head is necessary once the graduation carrier has been mounted. For exact alignment of the scanning head to the scale, it must in principle be aligned and adjustable in five axes (see illustration). This adjustment is greatly facilitated by the design of the scanning heads, with the corresponding mounting strategy and large mounting tolerances. For example, mounting of the scanning heads for ERA encoders is reduced to using the included spacer foil to set to scanning gap correctly.

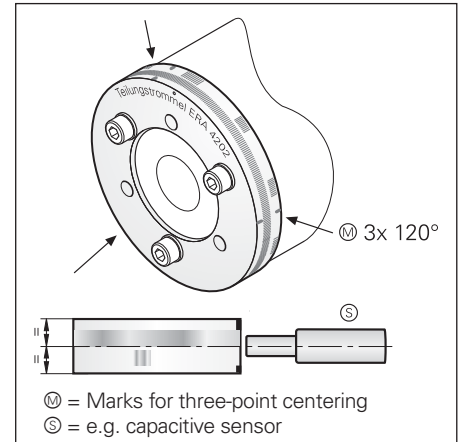

Three-point centering

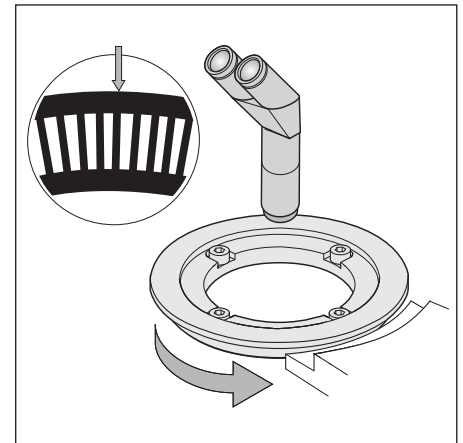

Optical centering

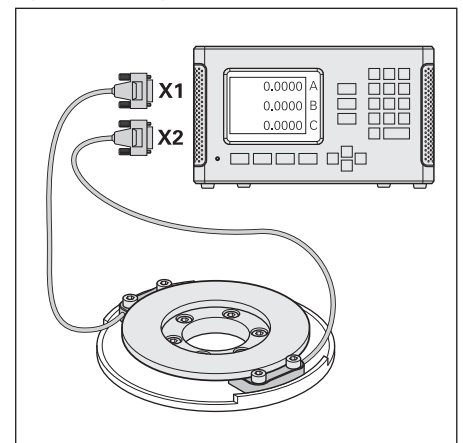

Centering with two scanning heads

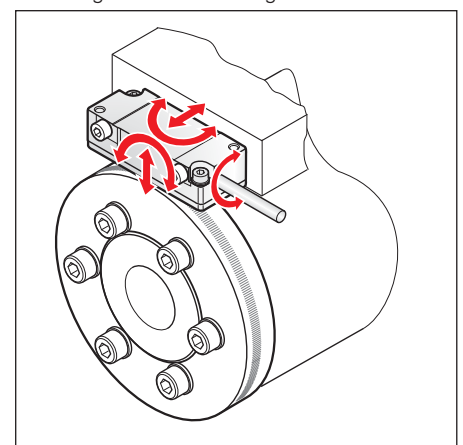

# ERP 880

The ERP 880 modular angle encoder consists of the following components: scanning unit, disk/hub assembly, and PCB. Cover caps for protection from contact or contamination can be supplied as accessories.

## Mounting the ERP 880

First the scanning unit is mounted on the stationary machine part with an alignment accuracy to the shaft of  $\pm 1.5 \mu\text{m}$ . Then the disk/hub assembly is screwed onto the front of the shaft, and is also aligned with a maximum eccentricity of  $\pm 1.5 \mu\text{m}$  to the scanning unit. Then the PCB is attached and connected to the scanning unit. Fine adjustment takes place with "electrical centering" using the PVM 9 (see *HEIDENHAIN measuring equipment*) and an oscilloscope. A housing can protect the ERP 880 from contamination.

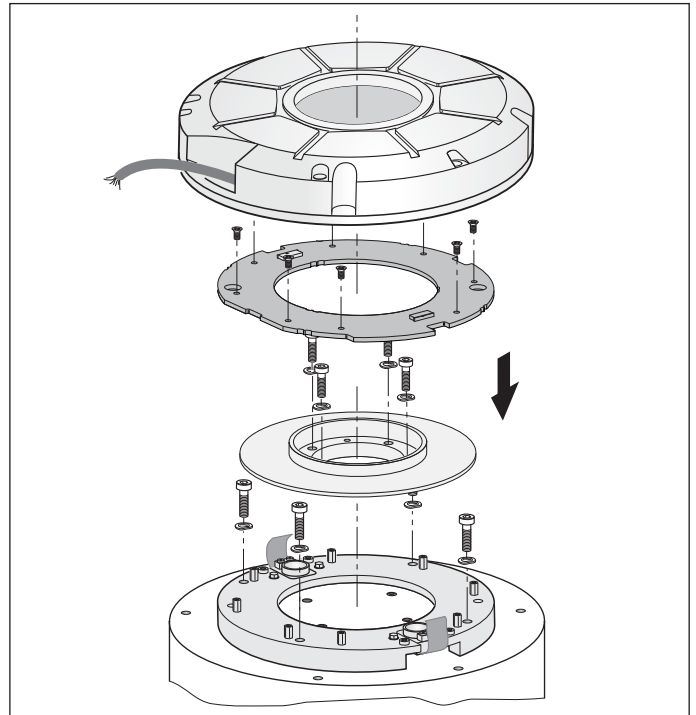

Mounting  
the ERP 880  
(in principle)

## IP 40 housing

With sealing ring for IP 40 protection  
Cable, 1 m, with male coupling, 12-pin  
ID 369774-01

## IP 64 housing

With shaft sealing ring for IP 64 protection  
Cable, 1 m, with male coupling, 12-pin  
ID 369774-02



# Mechanical design types and mounting

## ERP 4080/ERP 8080

The ERP 4080 and ERP 8080 modular angle encoders are intended for measuring tasks requiring utmost precision and resolution. They operate on the principle of interferentially scanning a phase grating. They consist of a scanning head and a disk/hub assembly.

### Determining the axial mounting tolerance

To attain the greatest possible accuracy, it is important to ensure that the wobble of the shaft and the wobble of the disk/hub assembly do not add to each other. The positions of the maximum and minimum wobble of the hub are marked. The wobble of the shaft must be measured and the maximum and minimum positions determined. The disk/hub assembly is then mounted such that the remaining wobble is minimized.

### Mounting the disk/hub assembly

The disk/hub assembly is slid onto the drive shaft, centered using the inside diameter of the hub, and fastened with screws. The circular scale can be centered using a dial indicator on the inside diameter of the hub, or optically using the centering circle integrated in the circular scale, or electrically with the aid of a second, diametrically opposed scanning head.

### Mounting the scanning head

The scanning head is fastened with two screws (or with the mounting aid) and the appropriate spacer foils on the mounting surface so that it can be moved slightly. The scanning head is adjusted electronically with the aid of the PWM 9 or PWT 18 (see *HEIDENHAIN measuring equipment*) by moving the scanning head within the mounting holes until the output signals reach an amplitude of  $\geq 0.9 V_{PP}$ .

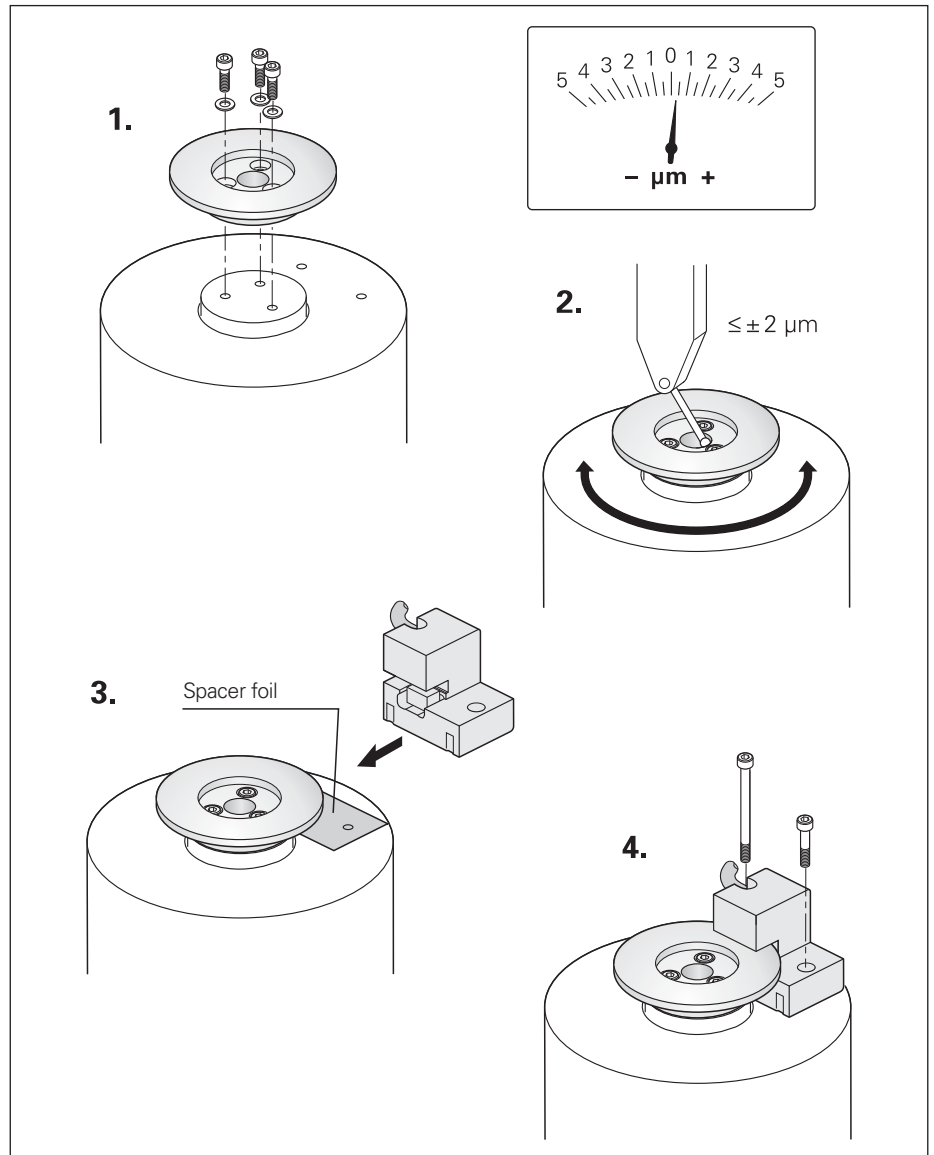

### Optional accessories

#### Mounting Aid

For adjusting the scanning head  
ID 622976-02

#### Adapter for length gauges

For measuring the mounting tolerances  
ID 627142-01

#### Spacer foils

For axial position adjustment

10 $\mu\text{m}$	ID 619943-01
20 $\mu\text{m}$	ID 619943-02
30 $\mu\text{m}$	ID 619943-03
40 $\mu\text{m}$	ID 619943-04
50 $\mu\text{m}$	ID 619943-05
60 $\mu\text{m}$	ID 619943-06
70 $\mu\text{m}$	ID 619943-07
80 $\mu\text{m}$	ID 619943-08
90 $\mu\text{m}$	ID 619943-09
100 $\mu\text{m}$	ID 619943-10

Set (one foil per gap from  
10  $\mu\text{m}$  to 100  $\mu\text{m}$ ): ID 619943-11

# ERO 6000, ERO 6100

The ERO 6000 and ERO 6100 modular angle encoders consist of a scanning head and a disk/hub assembly. These are positioned and adjusted relative to each other on the machine.

## Mounting the ERO 6000

A mating surface with fixed stop and defined inside diameter is advantageous for simple mounting of the scanning head. The scanning head is pressed against this mounting surface and secured with two screws. No further alignment is necessary. Then the disk/hub assembly is screwed onto the front of the shaft, and centered either mechanically via three-point centering or electrically. The scanning gap between the scanning head and graduated disk is already defined by the mounting surface, so no further adjustment is necessary here either.

## Mounting the ERO 6100

The disk/hub assembly is mounted on the shaft axially and centered optically. A mounting bracket with stop edge and defined inside diameter, and that can be adjusted axially, is advantageous for simple mounting of the scanning head. The scanning head is pressed against the stop surfaces of the mounting bracket and then secured with two screws. The included spacer foil is used to correctly set the scanning gap between the scanning head and graduated disk, and the mounting bracket is then secured.

The output signals are checked with the PWT. An APE 381 interface electronics unit is necessary for the ERO 6x80 (see *HEIDENHAIN measuring equipment*).

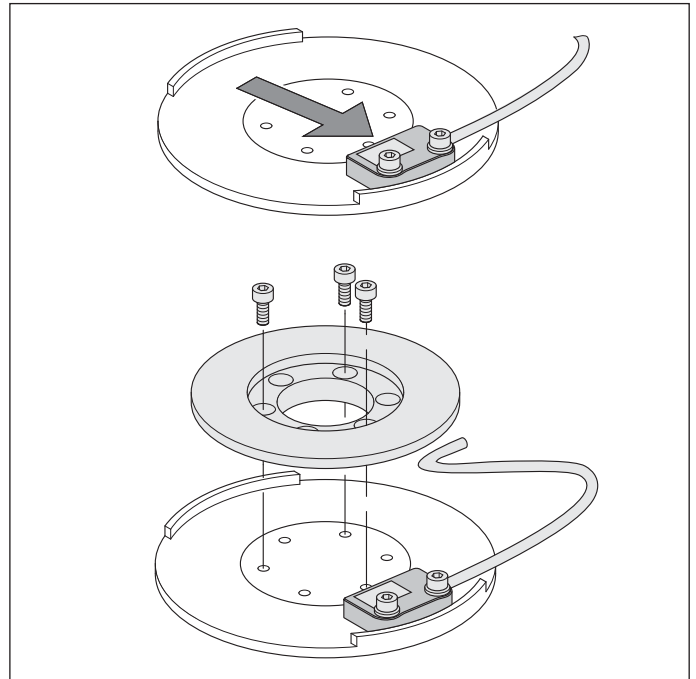

Mounting the  
ERO 6000

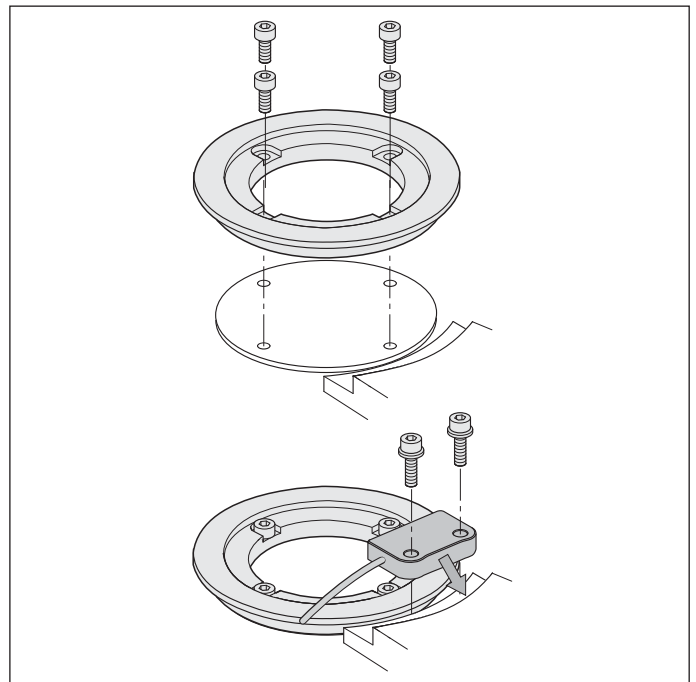

Mounting the  
ERO 6100



# Mechanical design types and mounting

## ERA 4000 series

The ERA 4000 modular angle encoders are supplied as two components: the scale drum and the scanning head.

The **scanning heads** of the ERA 4000 series feature very compact dimensions. The **scale drums** of the ERA 4000 are available in different versions to suit the particular application. The ERA 4x80 versions are available with various grating periods depending on the accuracy requirements. The appropriate scanning heads are shown in the table at right. Special design measures are required to protect the ERA from contamination. The ERA 4480 angle encoders are also available for various drum diameters with a protective cover. A special scanning head (with compressed-air inlet) is needed for versions with protective cover. The protective cover suited to the scale drum diameter must be ordered separately.

Special design features of the ERA modular angular encoders assure comparatively fast mounting and easy adjustment.

### Mounting the ERA 4x00 scale drum

The scale drum is slid onto the drive shaft and fastened with screws. The scale drum is centered via the centering collar on its inner circumference. The drum does not need to be adjusted. HEIDENHAIN recommends a slight oversize of the shaft on which the scale drum is to be mounted. For mounting, the scale drum may be slowly warmed on a heating plate over a period of approx. 10 minutes to a maximum temperature of 100 °C.

### Mounting the ERA 4202 scale drum

The scale drum is centered over three positions at 120° increments on its circumference and fastened with screws. The benefits of three-point centering and the solid design of the scale drum make it possible to attain a very high accuracy when the encoder is mounted, with relatively little mounting effort. The positions for centering are marked on the scale drum.

Application	Scale drum	Grating period	Type	Appropriate scanning head
High shaft speeds	Centering collar	20 µm	ERA 4200	ERA 4280
		40 µm	ERA 4400	ERA 4480
		80 µm	ERA 4800	ERA 4880
Increased positioning accuracy and high shaft speeds	Three-point centering	20 µm	ERA 4202	ERA 4280

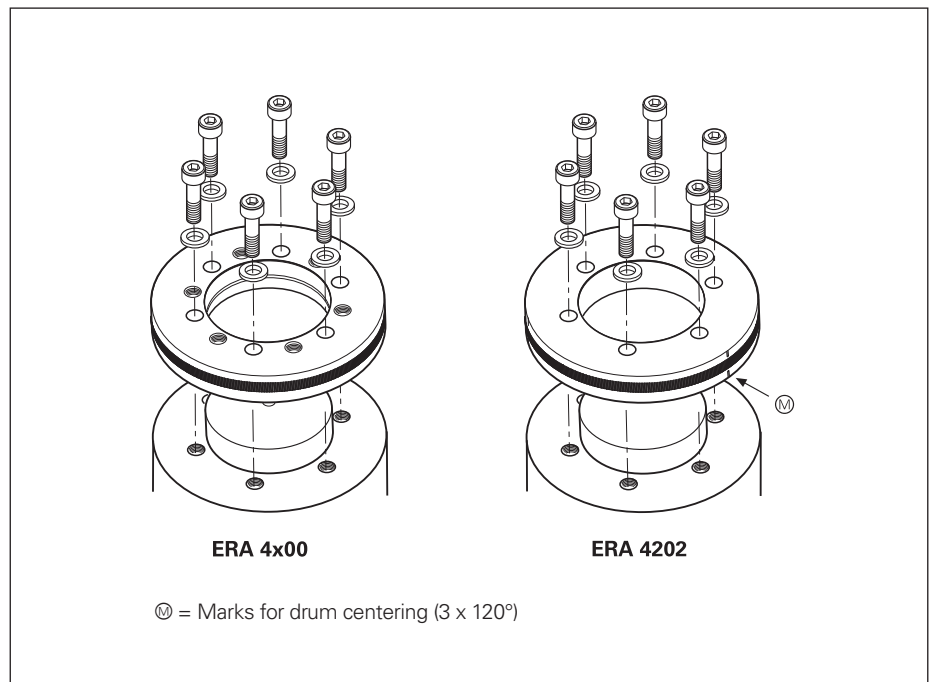

Mounting the scale drums



### Mounting the scanning head

In order to mount the scanning head, the spacer foil is held against the circumference of the scale drum. The scanning head is pressed against the foil, fastened, and the foil is removed. ERA 4000 encoders with 20 µm grating period also feature an eccentric bushing for fine adjustment of the scanning field.

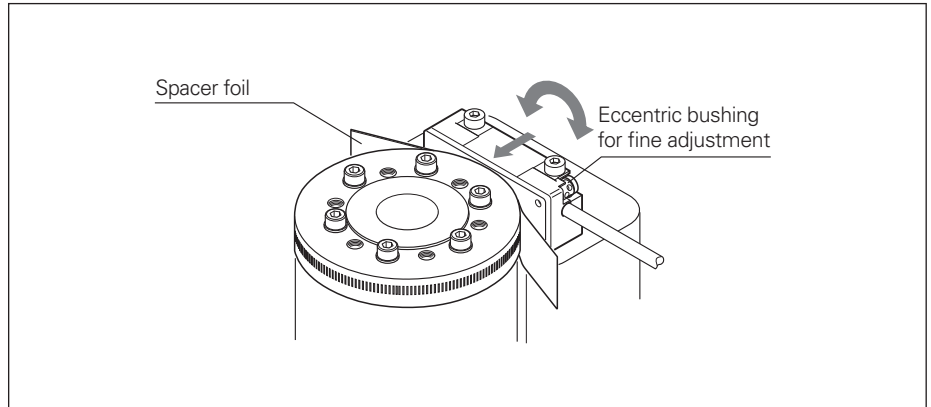

Mounting the Scanning Head

### Mounting the protective cover

The ERA 4480 modular angle encoders with protective cover are available in various diameters. This cover provides additional protection against contamination when compressed air is applied.

The scale drum and the scanning unit are mounted as described above. The separate spacer foil supplied with the protective cover is placed around the scale drum. It protects the scale drum when mounting the protective cover, and ensures that a constant scanning gap is maintained. Then the protective cover is slid onto the scale drum and secured. The spacer foil is removed. For information about the compressed-air inlet see *General mechanical information*.

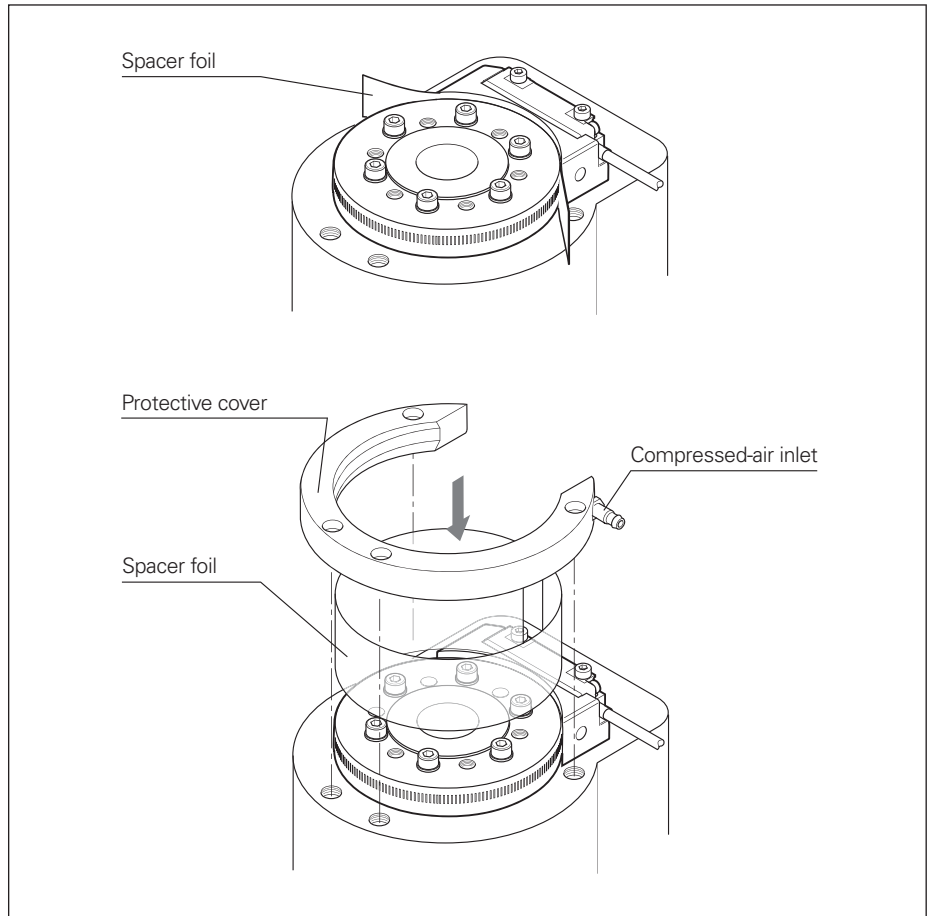

Mounting an ERA 4480 with protective cover

# Mechanical design types and mounting

## ERA 7000 and ERA 8000 series

The ERA 7000 and ERA 8000 series of angle encoders consist of a scanning unit and a one-piece steel scale tape. The steel scale tape is available up to a length of 30 m.

The tape is mounted on

- the **inside diameter** (ERA 7000 series) or
- the **outside diameter** (ERA 8000 series) of a machine element.

The ERA 74x0C and ERA 84x0C angle encoders are designed for **full-circle applications**. Thus, they are particularly suited to hollow shafts with large inside diameters (from approx. 400 mm) and to applications requiring an accurate measurement over a large circumference, e.g. large rotary tables, telescopes, etc.

In applications where there is no full circle, or measurement is not required over 360°, **circle segments** are available.

### Mounting the scale tape for full-circle applications

**ERA 74x0C:** An **internal slot** with a specified diameter is required as scale tape carrier. The tape is inserted starting at the butt joint and is clicked into the slot. The length is cut so that the tape is held in place by its own force.

**ERA 84x0C:** The scale tape is supplied with the halves of the tensioning cleat already mounted on the tape ends. An **external slot** is necessary for mounting. A recess must also be provided for the tensioning cleat. After the scale tape has been inserted, it is fastened aligned along the slot edge and tensioned using the tensioning cleat.

The scale tape ends are manufactured so exactly that only minor signal-form deviations can occur in the area of the butt joint. To make sure that the scale tape does not move within the slot, it is fixed with adhesive at multiple points in the area of the butt joint.

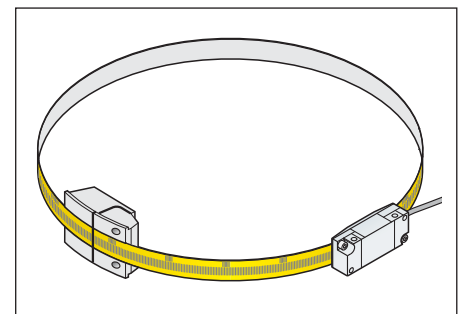
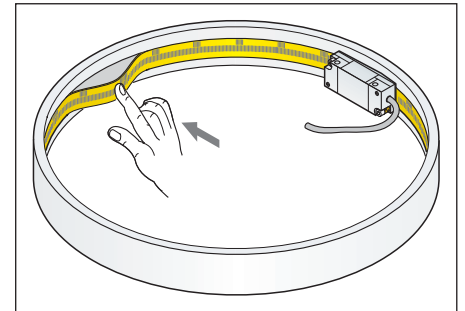

### Mounting the scale tape for circle segments

**ERA 74x1C:** An internal slot with a specified diameter is required. The two cam disks fixed in this slot are adjusted so that the scale can be snapped into the slot under pressure.

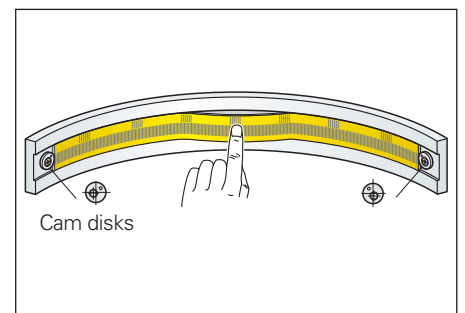

**ERA 84x1C:** The scale tape is supplied with premounted end pieces. An external slot with recesses for the bearing pieces is required for placing the scale tape. The end pieces are fitted with tension springs, which create an optimal bearing preload for increasing the accuracy of the scale tape, and evenly distribute the expansion over the entire length of the scale tape.

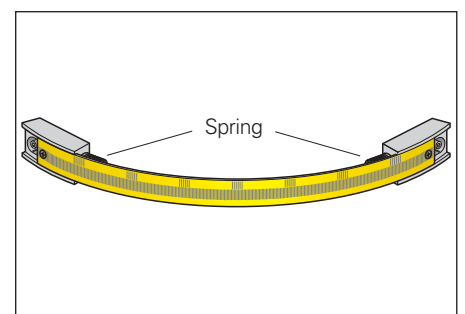

**ERA 84x2C:** An external slot or one-sided axial stop is recommended for placing the scale tape. The scale tape is supplied without tensioning elements. It must be preloaded with a spring balance, and secured using the two oblong holes.

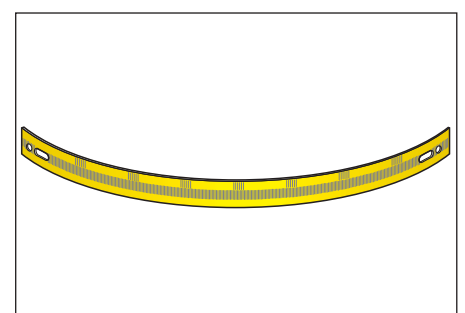

### Determining the mating diameter

In order to guarantee the correct functioning of the distance-coded reference marks, the circumference must be a multiple of 1000 grating periods. The association between the mating diameter and the line count can be seen in the table.

	Mating diameter in mm	Measuring range in degrees for segment versions
<b>ERA 7000C</b>	$n \cdot 0.01273112 + 0.3$	$n_1 \cdot 4.583204 : (D - 0.3)$
<b>ERA 8000C</b>	$n \cdot 0.0127337 - 0.3$	$n_1 \cdot 4.584121 : (D + 0.3)$

$n$  = line count of full circle;  $n_1$  = line count of measuring range  
 $D$  = mating diameter [mm]

### Specification of segment angle

For segment versions, the angle available as measuring range must be a multiple of 1000 grating periods. Also, the circumference of the theoretical full circle must be a multiple of 1000 grating periods, since this often simplifies integration with the numerical control.

### Mounting the scanning head

In order to mount the scanning head, the spacer foil is held against the circumference of the scale drum. The scanning head is pressed against the foil, fastened, and the foil is removed. In addition, the scanning field can be finely adjusted via a cam bushing.

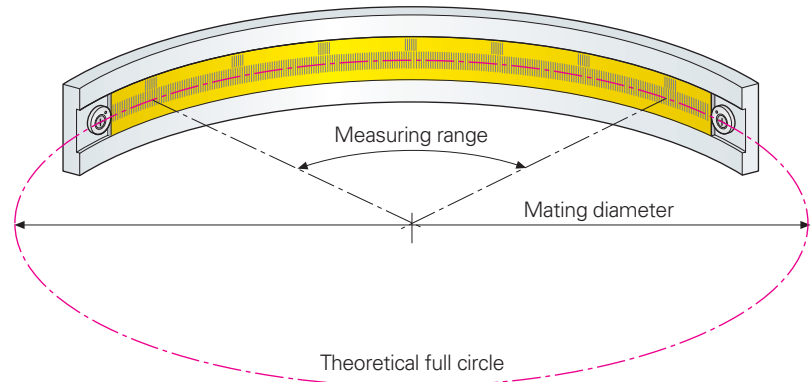

### Checking the output signals at the butt joint

In order to check whether the scale tapes of the ERA 74x0 C and ERA 84x0 C have been mounted correctly, the output signals should be checked at the butt joint—before the adhesive has hardened.

The quality of the output signals can be checked using HEIDENHAIN's PWT phase-angle testing unit. When the scanning head is moved along the scale tape, the PWT graphically displays the quality of the signals as well as the position of the reference mark.

The PWM 9 phase angle measuring unit calculates a quantitative value for the deviation of the actual output signals from the ideal signal (see *HEIDENHAIN measuring equipment*).

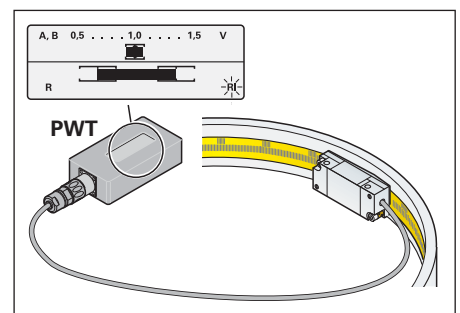
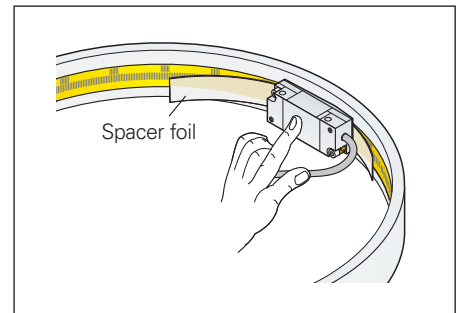

# General mechanical information

## Protection

For angle encoders **without integral bearing**, the necessary protection against contamination and contact must be ensured during installation through design measures such as additional labyrinth seals.

Unless otherwise indicated, all RCN, RON, RPN and ROD angle encoders **with integral bearing** meet protection standard IP 67 according to EN 60 529 or IEC 60 529 for the housing and cable outlet, and IP 64 at the shaft inlet.

Some versions of the ERA 4480 angle encoders up to a drum inside diameter of 180 mm are available with an optional protective cover. Connection to a source of compressed air slightly above atmospheric pressure provides additional protection against contamination.

The compressed air introduced directly onto the encoders must be cleaned by a micro filter, and must comply with the following quality classes as per **ISO 8573-1** (2010 edition):

- Solid contaminants: **Class 1**  

Particle size	Number of particles per m <sup>3</sup>
0.1 µm to 0.5 µm	≤ 20000
0.5 µm to 1.0 µm	≤ 400
1.0 µm to 5.0 µm	≤ 10
- Max. pressure dew point: **Class 4**  
 (pressure dew point at 3 °C)
- Total oil content: **Class 1**  
 (max. oil concentration: 0.01 mg/m<sup>3</sup>)

For optimum supply of sealing air to the angle encoders with integral bearing, the required air flow is 1 to 4 l/min per encoder. Ideally the air flow is regulated by the HEIDENHAIN connecting pieces with integrated throttle (see *Accessories*). At an inlet pressure of approx.  $1 \cdot 10^5$  Pa (1 bar), the throttles ensure the prescribed volume of airflow.

Accessory:

**DA 400 compressed air unit**  
 ID 894602-01

## DA 400

HEIDENHAIN offers the DA 400 compressed-air filter system for purifying the compressed air. It is designed specifically for the introduction of compressed air into encoders.

The DA 400 consists of three filter stages (pre-filter, fine filter and activated carbon filter) and a pressure regulator with pressure gauge. The pressure gauge and the automatic pressure switch (which is available as an accessory) effectively monitor the sealing air.

The compressed air introduced into the DA 400 must fulfill the requirements of the following purity classes as per DIN/ISO 8573-1 (2010 edition):

- Solid contaminants: **Class 5**  

Particle size	Number of particles per m <sup>3</sup>
0.1 µm to 0.5 µm	Not specified
0.5 µm to 1.0 µm	Not specified
1.0 µm to 5.0 µm	≤ 100000
- Max. pressure dew point: **Class 6**  
 (pressure dew point at 10 °C)
- Total oil content: **Class 4**  
 (max. oil concentration: 5 mg/m<sup>3</sup>)

The following components are necessary for connection to angle encoders:

### Connecting piece, straight

With throttle and gasket  
 ID 226270-xx

### Connecting piece, straight, short

With throttle and gasket  
 ID 275239-xx

### M5 coupling joint, swiveling

With seal  
 ID 207834-xx



DA 400

For more information, ask for our *DA 400* Product Information Sheet.

### Temperature range

The angle encoders are inspected at a **reference temperature** of 22 °C. The system accuracy given in the calibration chart applies at this temperature.

### The operating temperature range

indicates the ambient temperature limits between which the angle encoders will function properly.

The **storage temperature range** of –30 °C to +80 °C is valid as long as the unit remains in its packaging (ERP 4080/ERP 8080: 0 °C to 60 °C).

### Protection against contact

After encoder installation, all rotating parts must be protected against accidental contact during operation.

### Acceleration

Angle encoders are subject to various types of acceleration during operation and mounting.

- The indicated maximum values for **vibration resistance** are valid according to EN 60068-2-6.
- The maximum permissible acceleration values (semi-sinusoidal shock) for **shock and impact** are valid for 6 ms (EN 60 068-2-27).

Under no circumstances should a hammer or similar implement be used to adjust or position the encoder.

### Shaft speeds

The maximum permissible shaft speeds for the ERA 4000 angle encoders series were determined according to the FKM guideline. This guideline serves as mathematical attestation of component strength with regard to all relevant influences and it reflects the latest state of the art. The requirements for fatigue strength (10<sup>7</sup> million reversals of load) were considered in the calculation of the permissible shaft speeds. Because installation has a significant influence, all requirements and directions in the specifications and mounting instructions must be followed for the shaft-speed data to be valid.

### Expendable parts

Encoders from HEIDENHAIN are designed for a long service life. Preventive maintenance is not required. However, they contain components that are subject to wear, depending on the application and manipulation. These include in particular cables with frequent flexing.

Other such components are the bearings of encoders with integral bearing, shaft sealing rings on rotary and angle encoders, and sealing lips on sealed linear encoders.

### System tests

Encoders from HEIDENHAIN are usually integrated as components in larger systems. Such applications require **comprehensive tests of the entire system** regardless of the specifications of the encoder.

The specifications shown in this brochure apply to the specific encoder, not to the complete system. Any operation of the encoder outside of the specified range or for any other than the intended applications is at the user's own risk.

### Assembly

Work steps to be performed and dimensions to be maintained during mounting are specified solely in the mounting instructions supplied with the unit. All data in this catalog regarding mounting are therefore provisional and not binding; they do not become terms of a contract.

DIADUR, AURODUR and METALLUR are registered trademarks of DR. JOHANNES HEIDENHAIN GmbH, Traunreut.

# ERP 880

Incremental angle encoder  
for very high accuracy

- High resolution
- Protective cover as accessory

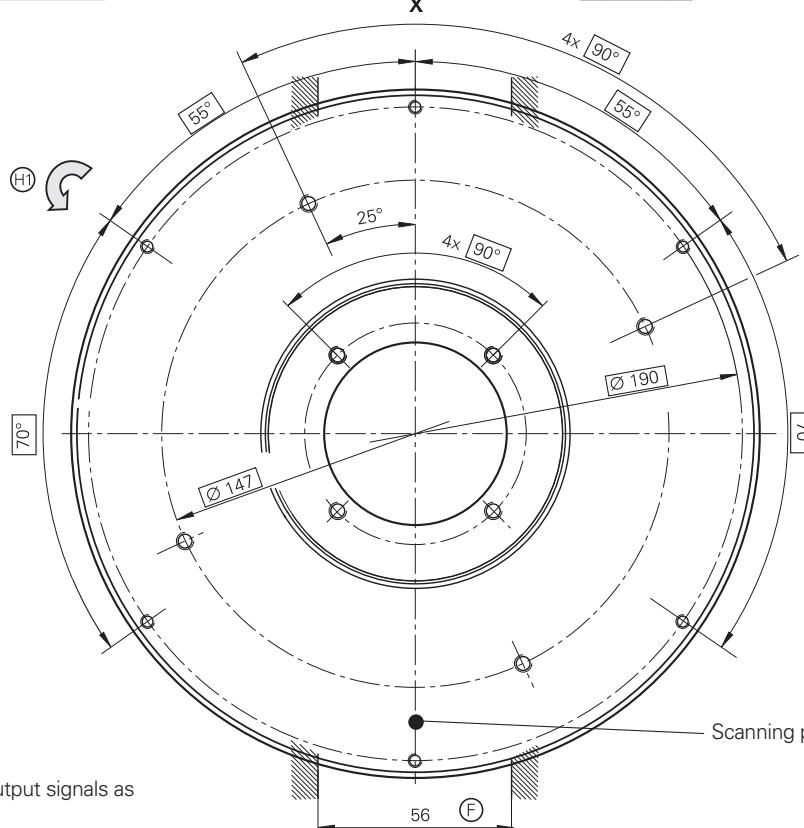
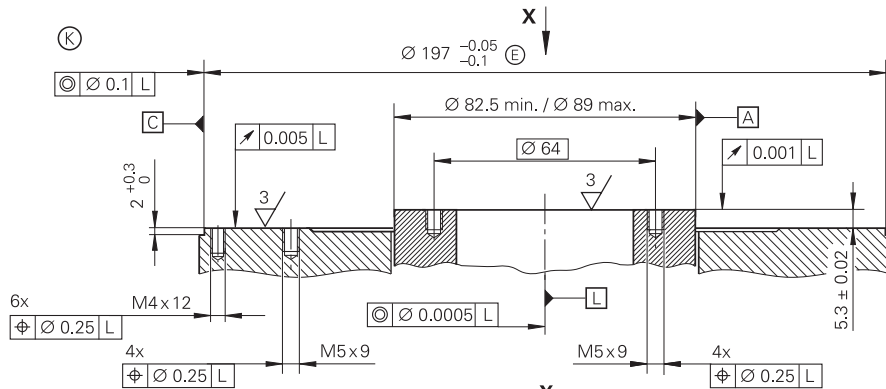
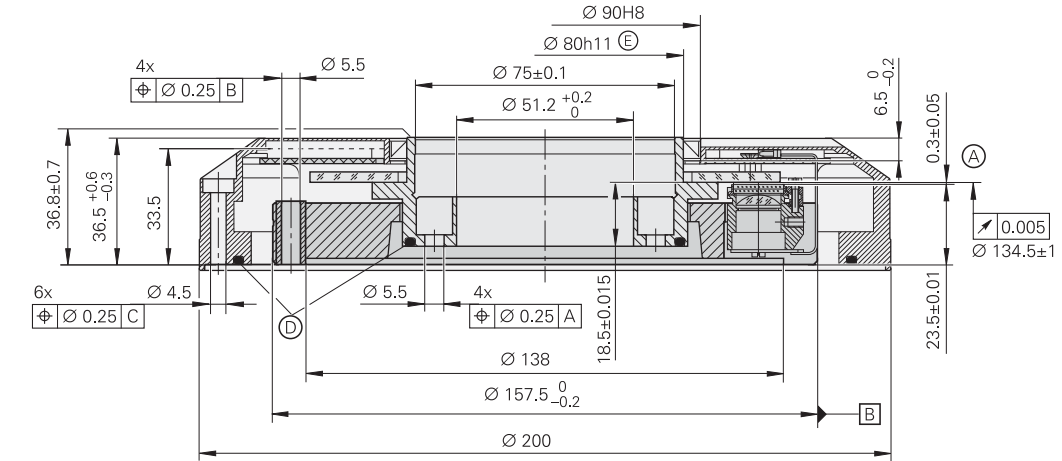

mm  
  
 Tolerancing ISO 8015  
 ISO 2768 - m H  
 < 6 mm: ±0.2 mm

Cable radial, also usable axially

Ⓐ = Disk-to-scanning-reticle gap

Ⓛ = Axis of bearing rotation

Ⓞ = Required mating dimensions

Ⓟ = Space needed for service

Ⓠ = Seal

Ⓡ = Direction of shaft rotation for output signals as per the interface description

ERP 880	
<b>Measuring standard</b>	DIADUR phase grating on glass
Signal periods	180 000
<b>Accuracy of graduation</b>	± 0.9"
<b>Position error per signal period <sup>1)</sup></b>	± 0.1"
<b>Reference marks</b>	One
<b>Hub inside diameter</b>	51.2 mm
Mech. permissible speed	≤ 1 000 min <sup>-1</sup>
Moment of inertia of rotor	1.2 · 10 <sup>-3</sup> kgm <sup>2</sup>
Permissible axial motion of measured shaft	≤ ± 0.05 mm
<b>Interface</b>	~ 1 V <sub>PP</sub>
Cutoff frequency	-3 dB ≥ 800 kHz -6 dB ≥ 1.3 MHz
<b>Electrical connection</b>	<i>With housing:</i> Cable 1 m, with M23 coupling <i>Without housing:</i> Via 12-pin PCB connector (adapter cable ID 372164-xx)
Cable length	≤ 150 m (with HEIDENHAIN cable)
Power supply	5 V ± 0.5 V DC
Current requirement	≤ 250 mA (without load)
<b>Vibration</b> 55 to 2000 Hz <b>Shock</b> 6 ms	≤ 50 m/s <sup>2</sup> (EN 60068-2-6) ≤ 1000 m/s <sup>2</sup> (EN 60068-2-27)
<b>Operating temperature</b>	0 °C to 50 °C
<b>Protection*</b> EN 60529	<i>Without housing:</i> IP 00 <i>With housing:</i> IP 40 <i>With housing and shaft seal:</i> IP 64
<b>Starting torque</b>	–      0.25 Nm
<b>Weight</b>	3.0 kg      3.1 kg incl. housing

\* Please select when ordering

<sup>1)</sup> The position error within one signal period and the accuracy of the graduation result together in the encoder-specific error; for additional error through mounting and the bearing of the measured shaft, see *Measuring accuracy*



# ERP 4080/ERP 8080

Incremental angle encoder for high accuracy

- Very high resolution
- Consists of scanning head and disk/hub assembly



## ERP 4080

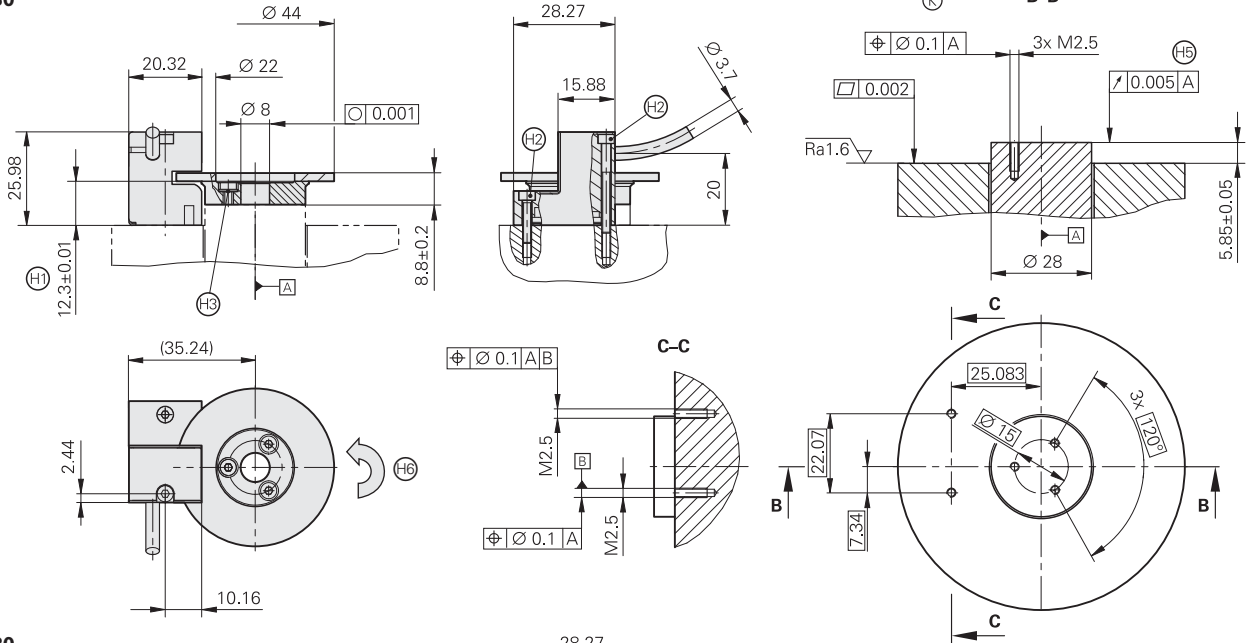

## ERP 8080

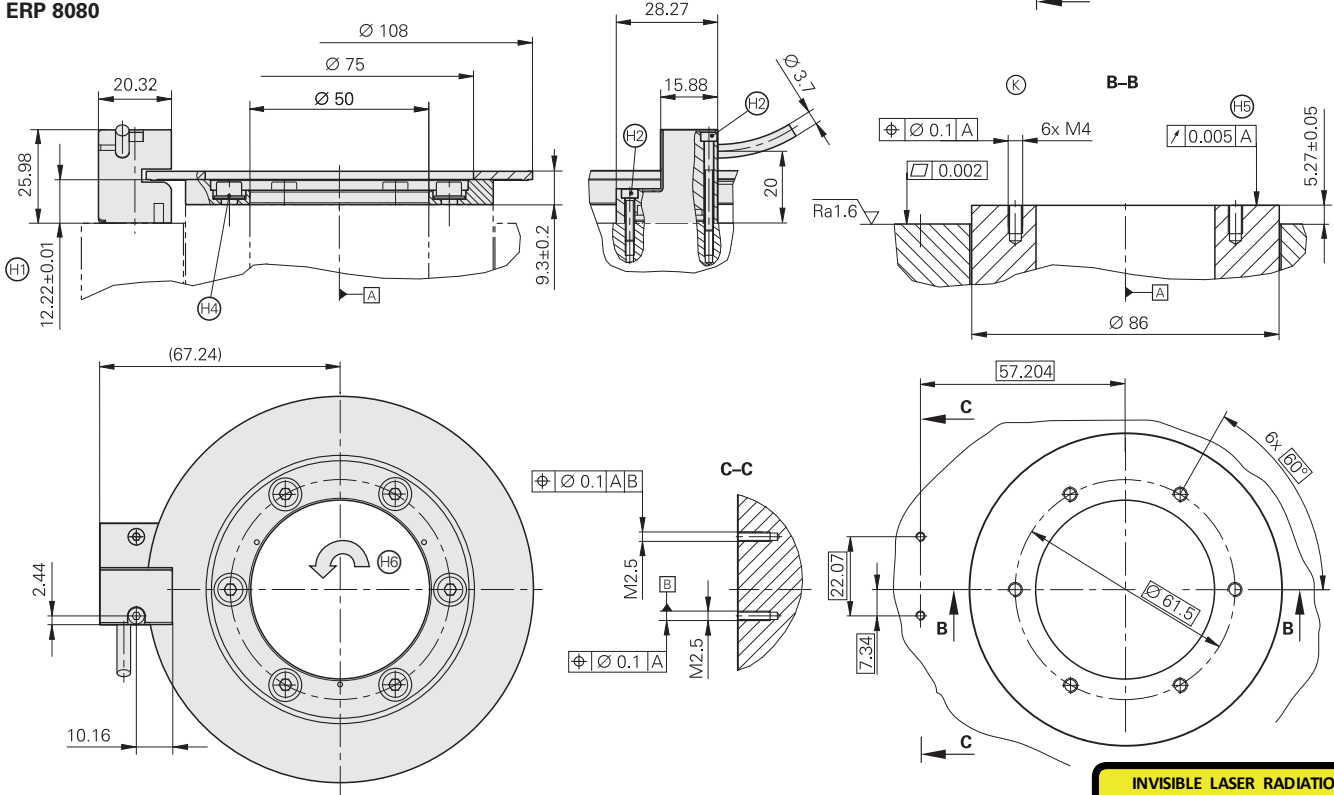

mm  
 Tolerancing ISO 8015  
 ISO 2768 - m H  
 < 6 mm: ±0.2 mm

- ⊙ = Bearing
- ⊙ = Required mating dimensions
- ⊕ = Mounting clearance set with spacer foil
- ⊕ = Cylinder head screw ISO 4762-A2-M2.5
- ⊕ = Cylinder head screw ISO 4762-A2-M2.5 and washer ISO 7089-2.5-140HV-A2
- ⊕ = Cylinder head screw ISO 4762-A2-M4 and washer ISO 7089-4-140HV-A2
- ⊕ = Mounting surface not convex
- ⊕ = Direction of shaft rotation for output signals as per the interface description

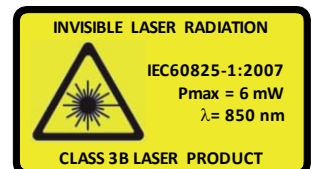

Scanning head	AK ERP 4080	AK ERP 8080
Interface	~ 1 V <sub>pp</sub>	
Cutoff frequency -3 dB	≥ 250 kHz	
Electrical connection	Cable 1 m, with D-sub connector (15-pin)	
Cable length	≤ 30 m (with HEIDENHAIN cable)	
Power supply	5 V DC ± 0.25 V	
Current requirement	≤ 150 mA (without load)	
Laser	<i>Scanning head and graduated disk mounted: Class 1</i> <i>Scanning head not mounted: Class 3B</i> <i>Laser diode used: Class 3B</i>	
Vibration 55 to 2000 Hz Shock 6 ms	≤ 50 m/s <sup>2</sup> (EN 60068-2-6) ≤ 500 m/s <sup>2</sup> (EN 60068-2-27)	
Operating temperature	15 °C to 40 °C	
Weight	Approx. 33 g (without cable)	

Circular scale	TKN ERP 4080	TKN ERP 8080 (scale)
Measuring standard	Phase grating on glass	
Signal periods	131 072	360 000
Accuracy of graduation	± 2"	± 1"
Position error per signal period <sup>1)</sup>	± 0.1"	± 0.05"
Reference marks	No	
Hub inside diameter	8 mm	50 mm
Mech. permissible speed	≤ 300 min <sup>-1</sup>	≤ 100 min <sup>-1</sup>
Moment of inertia of rotor	5 · 10 <sup>-6</sup> kgm <sup>2</sup>	250 · 10 <sup>-6</sup> kgm <sup>2</sup>
Permissible axial motion of measured shaft	≤ ± 0.01 mm (including wobble)	
Protection EN 60529	IP 00 (for clean room application)	
Weight	Approx. 36 g	Approx. 180 g

<sup>1)</sup> The position error within one signal period and the accuracy of the graduation result together in the encoder-specific error; for additional error through mounting and the bearing of the measured shaft, see Measuring accuracy

# ERO 6000 series

Incremental angle encoder for high accuracy

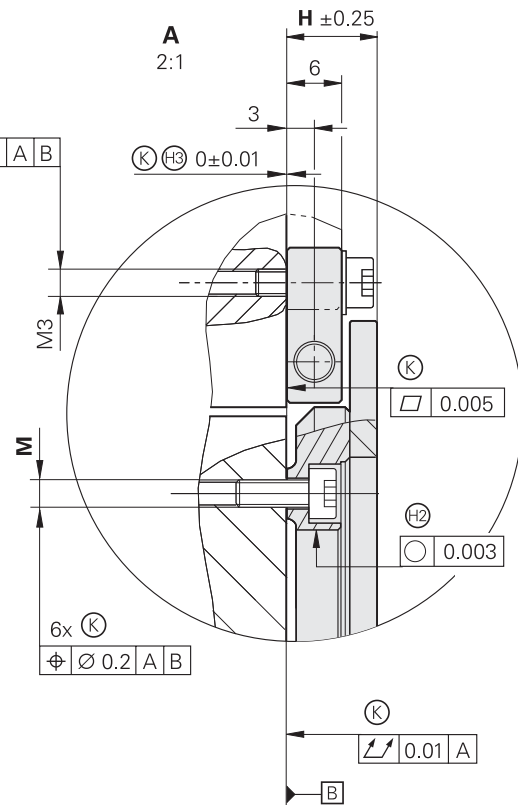
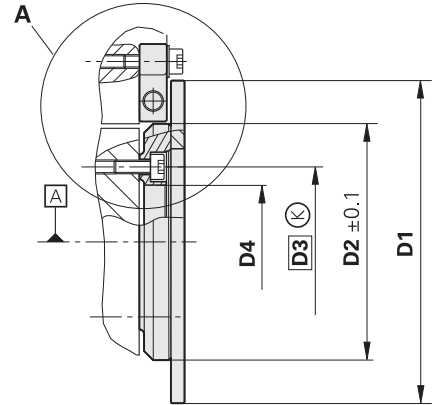
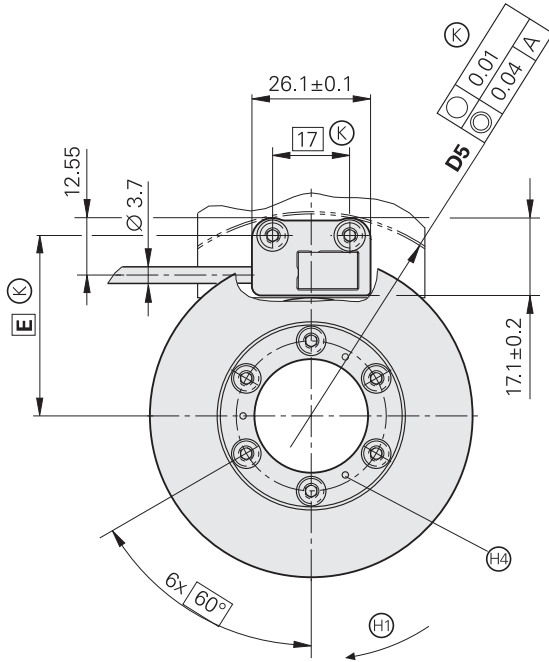

- Compact design
- Low weight, low moment of inertia
- Consists of scanning head and disk/hub assembly



D1	D2	D3	D4	D5	E	H	M
Ø 71	Ø 52	Ø 33	Ø 25H6	Ø 88.9H6	39.7	9.9	M3
Ø 150	Ø 130	Ø 107	Ø 95 <sup>+0.015</sup> <sub>0</sub>	Ø 166H6	78.7	10.2	M4

Tolerancing ISO 8015  
 ISO 2768 - m H  
 < 6 mm: ±0.2 mm

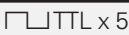
- ▣ = Bearing
- ⊙ = Required mating dimensions
- ⊕ = Positive direction of rotation
- ⊖ = Centering collar
- ⊗ = Mounting tolerance between mounting surface of scanning head and disk/hub assembly
- ⊗ = Marks for centering the circular scale (3 x 120°)

Scanning head	AK ERO 6080		AK ERO 6070	
Interface	 1 V <sub>pp</sub>	 x 5	 x 10	 x 50
Reference mark signal	Square-wave pulse			
Integrated interpolation*	–	5-fold	10-fold	50-fold
Cutoff frequency –3 dB	≥ 200 kHz	–	–	–
Scanning frequency	–	≤ 200 kHz	≤ 100 kHz	≤ 25 kHz
Edge separation a	–	≥ 0.220 μs	≥ 0.220 μs	≥ 0.175 μs
<b>Electrical connection</b>	Cable 3 m with male D-sub connector (15-pin), interface electronics for ERO 6070 in the connector			
Cable length	≤ 30 m			
Power supply	5 V DC ± 0.25 V			
Current requirement	< 100 mA (without load)	< 200 mA (without load)		
<b>Vibration</b> 55 to 2000 Hz <b>Shock</b> 6 ms	≤ 200 m/s <sup>2</sup> (EN 60068-2-6) ≤ 500 m/s <sup>2</sup> (EN 60068-2-27)			
<b>Operating temperature</b>	0 °C to 50 °C			
<b>Weight</b> Scanning head Connector Cable	Approx. 6 g (w/o cable) Approx. 32 g Approx. 22 g/m	Approx. 6 g (w/o cable) Approx. 140 g Approx. 22 g/m		

Circular scale	TKN ERO 6000	
Measuring standard	METALLUR graduation on glass	
Signal periods*	9000	18000
Accuracy of graduation	± 5"	± 3.5"
Position error per signal period <sup>1)</sup>	± 2"	± 1"
Reference marks	One	
Hub inside diameter	25 mm	95 mm
Circular scale outside diameter	71 mm	150 mm
Mech. permissible speed	≤ 1600 min <sup>-1</sup>	≤ 800 min <sup>-1</sup>
Moment of inertia	44 x 10 <sup>-6</sup> kgm <sup>2</sup>	1.1 x 10 <sup>-3</sup> kgm <sup>2</sup>
Permissible axial motion	≤ 0.1 mm	
Protection EN 60529	IP 00	
Weight	Approx. 84 g	Approx. 323 g

\* Please select when ordering

<sup>1)</sup> The position error within one signal period and the accuracy of the graduation result together in the encoder-specific error; for additional error through mounting and the bearing of the measured shaft, see *Measuring accuracy*

# ERO 6180

## Incremental rotary encoder

- Compact design
- Low weight, low moment of inertia
- Consists of scanning head and disk/hub assembly

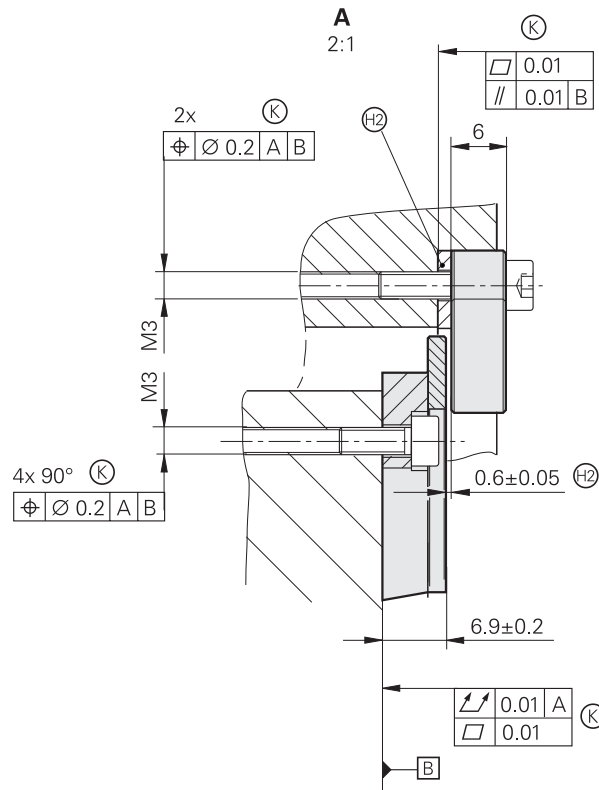
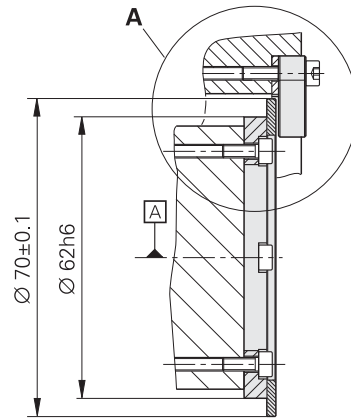
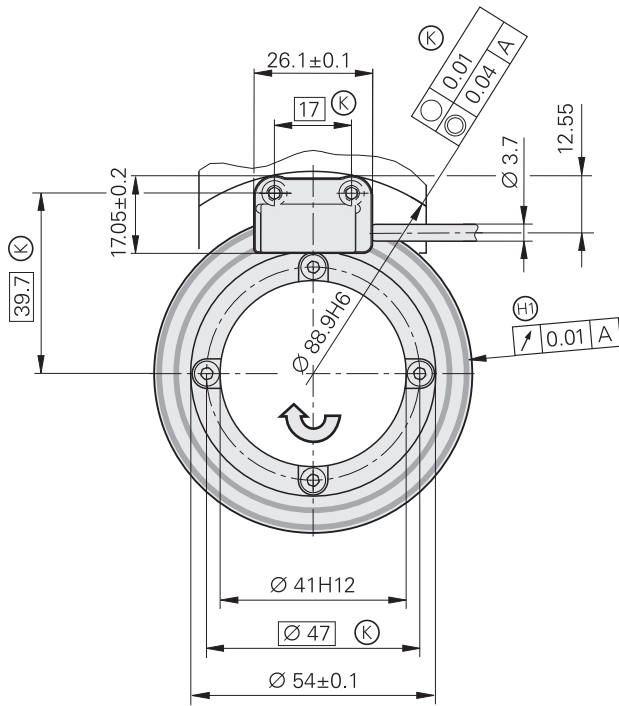

mm



Tolerancing ISO 8015  
ISO 2768 - m H  
< 6 mm: ±0.2 mm

- ▣ = Bearing
- ⊙ = Required mating dimensions
- ⊕ = Centering of the circular scale with hub by the customer via the graduation
- ⊗ = Scanning gap adjustment by means of a shim
- ↻ = Direction of scanning unit motion for output signals in accordance with interface description

<b>Scanning head</b>	<b>AK ERO 6180</b>
<b>Interface</b>	 1 V <sub>pp</sub>
Reference mark signal	Square-wave pulse
Cutoff frequency -3 dB	≥ 200 kHz
<b>Electrical connection</b>	Cable 3 m with D-sub connector (male, 15-pin)
Cable length	≤ 30 m
Power supply	5 V DC ± 0.25 V
Current requirement	< 100 mA (without load)
<b>Vibration</b> 55 to 2000 Hz <b>Shock</b> 6 ms	≤ 200 m/s <sup>2</sup> (EN 60068-2-6) ≤ 500 m/s <sup>2</sup> (EN 60068-2-27)
<b>Operating temperature</b>	0 °C to 50 °C
<b>Weight</b> Scanning head Connector Cable	Approx. 6 g (without cable) Approx. 32 g Approx. 22 g/m

<b>Circular scale</b>	<b>TKN ERO 6100</b>
<b>Measuring standard</b>	Chromium graduation on glass
<b>Signal periods</b>	4096
<b>Accuracy of graduation</b>	± 10"
<b>Position error per signal period</b> <sup>1)</sup>	± 5"
<b>Reference marks</b>	One
<b>Hub inside diameter</b>	41 mm
<b>Circular scale outside diameter</b>	70 mm
Mech. permissible speed	≤ 3500 min <sup>-1</sup>
Moment of inertia	50 × 10 <sup>-6</sup> kgm <sup>2</sup>
Permissible axial motion	≤ 0.1 mm
<b>Protection</b> EN 60529	IP 00
<b>Weight</b>	Approx. 71 g

<sup>1)</sup> The position error within one signal period and the accuracy of the graduation result together in the encoder-specific error; for additional error through mounting and the bearing of the measured shaft, see *Measuring accuracy*

# ERA 4280C, ERA 4480C, ERA 4880C

Incremental angle encoder for high accuracy

- Steel scale drum with centering collar
- Optional protective cover available for ERA 4480 C
- Consists of scanning head and scale drum



ERA 4000



ERA 4000 with protective cover

<b>Scanning head</b>	
<b>Interface</b>	
Cutoff frequency -3 dB	
<b>Electrical connection</b>	
Cable length	
Power supply	
Current requirement	
<b>Vibration</b> 55 to 2000 Hz	
<b>Shock</b> 6 ms	
<b>Operating temperature</b>	
<b>Weight</b>	Scanning head

<b>Scale drum</b>	
<b>Measuring standard</b>	
Coefficient of expansion	
<b>Signal periods/ Position error per signal period<sup>1)</sup></b>	ERA 4200
	ERA 4400
	ERA 4800
<b>Accuracy of graduation</b>	
<b>Reference marks</b>	
<b>Drum inside diameter*</b>	
<b>Drum outside diameter*</b>	
Mech. permissible speed	
Moment of inertia of rotor	
Permissible axial movement	
<b>Protection*</b> EN 60529	
Without protective cover	
With protective cover <sup>2)</sup> and compressed air	
<b>Weight</b>	Scale drum
	Protective cover



<b>AK ERA 4280</b> graduation period 20 $\mu\text{m}$ <b>AK ERA 4480</b> graduation period 40 $\mu\text{m}$ <b>AK ERA 4880</b> graduation period 80 $\mu\text{m}$									
$\sim 1 V_{PP}$									
$\geq 350 \text{ kHz}$									
Cable 1 m, with M23 coupling (12-pin)									
$\leq 150 \text{ m}$ (with HEIDENHAIN cable)									
$5 \text{ V} \pm 0.5 \text{ V DC}$									
$< 100 \text{ mA}$ (without load)									
$\leq 200 \text{ m/s}^2$ (EN 60068-2-6) $\leq 1000 \text{ m/s}^2$ (EN 60068-2-27)									
$-10 \text{ }^\circ\text{C}$ to $80 \text{ }^\circ\text{C}$									
20 g; Scanning head for protective cover: 35 g (each without cable)									

<b>TTR ERA 4200C</b> graduation period 20 $\mu\text{m}$ <b>TTR ERA 4400C</b> graduation period 40 $\mu\text{m}$ <b>TTR ERA 4800C</b> graduation period 80 $\mu\text{m}$									
Steel drum $\alpha_{\text{therm}} \approx 10.5 \cdot 10^{-6} \text{ K}^{-1}$									
12000/ $\pm 1.1$ "	16384/ $\pm 0.8$ "	20000/ $\pm 0.7$ "	28000/ $\pm 0.5$ "	32768/ $\pm 0.4$ "	40000/ $\pm 0.4$ "	52000/ $\pm 0.3$ "	–	–	–
6000/ $\pm 2.2$ "	8192/ $\pm 1.6$ "	10000/ $\pm 1.3$ "	14000/ $\pm 1.0$ "	16384/ $\pm 0.8$ "	20000/ $\pm 0.7$ "	26000/ $\pm 0.5$ "	38000/ $\pm 0.4$ "	44000/ $\pm 0.3$ "	–
3000/ $\pm 4.4$ "	4096/ $\pm 3.2$ "	5000/ $\pm 2.6$ "	7000/ $\pm 1.9$ "	8192/ $\pm 1.6$ "	10000/ $\pm 1.3$ "	13000/ $\pm 1.0$ "	–	–	–
$\pm 5$ "	$\pm 3.7$ "	$\pm 3$ "	$\pm 2.5$ "						$\pm 2$ "
Distance-coded, one upon request									
40 mm	70 mm	80 mm	120 mm	150 mm	180 mm	270 mm	425 mm	512 mm	
76.75 mm	104.63 mm	127.64 mm	178.55 mm	208.89 mm	254.93 mm	331.31 mm	484.07 mm	560.46 mm	
10000 $\text{min}^{-1}$	8500 $\text{min}^{-1}$	6250 $\text{min}^{-1}$	4500 $\text{min}^{-1}$	4250 $\text{min}^{-1}$	3250 $\text{min}^{-1}$	2500 $\text{min}^{-1}$	1800 $\text{min}^{-1}$	1500 $\text{min}^{-1}$	
$0.27 \cdot 10^{-3} \text{ kgm}^2$	$0.81 \cdot 10^{-3} \text{ kgm}^2$	$1.9 \cdot 10^{-3} \text{ kgm}^2$	$7.1 \cdot 10^{-3} \text{ kgm}^2$	$12 \cdot 10^{-3} \text{ kgm}^2$	$28 \cdot 10^{-3} \text{ kgm}^2$	$59 \cdot 10^{-3} \text{ kgm}^2$	$195 \cdot 10^{-3} \text{ kgm}^2$	$258 \cdot 10^{-3} \text{ kgm}^2$	
$\leq \pm 0.5 \text{ mm}$ (scale drum relative to scanning head)									
IP 00									
IP 40	IP 40	IP 40	IP 40	IP 40	IP 40	IP 40	–	–	–
$\approx 0.28 \text{ kg}$	$\approx 0.41 \text{ kg}$	$\approx 0.68 \text{ kg}$	$\approx 1.2 \text{ kg}$	$\approx 1.5 \text{ kg}$	$\approx 2.3 \text{ kg}$	$\approx 2.6 \text{ kg}$	$\approx 3.8 \text{ kg}$	$\approx 3.6 \text{ kg}$	
$\approx 0.07 \text{ kg}$	$\approx 0.1 \text{ kg}$	$\approx 0.12 \text{ kg}$	$\approx 0.17 \text{ kg}$	$\approx 0.22 \text{ kg}$	$\approx 0.26 \text{ kg}$	$\approx 0.35 \text{ kg}$	–	–	–

\* Please select when ordering

<sup>1)</sup> The position error within one signal period and the accuracy of the graduation result together in the encoder-specific error; for additional error through mounting and the bearing of the measured shaft, see *Measuring accuracy*

<sup>2)</sup> Only with ERA 4480; the protective cover must be ordered separately

# ERA 4280C, ERA 4480C, ERA 4880C

Without protective cover

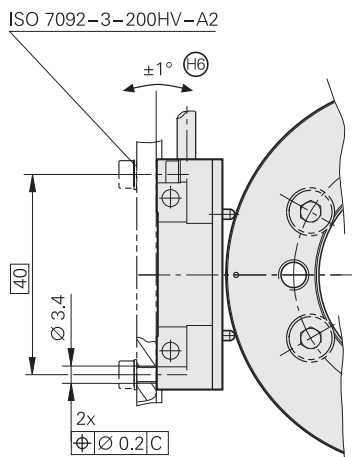
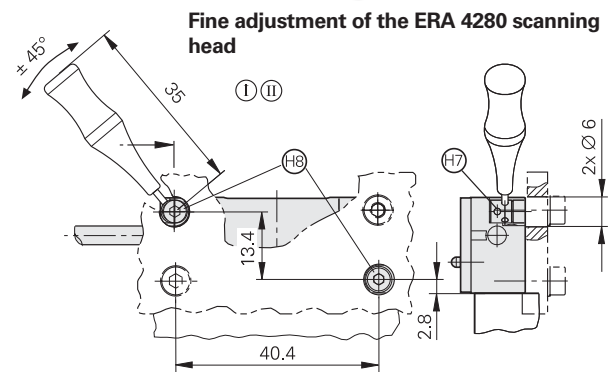
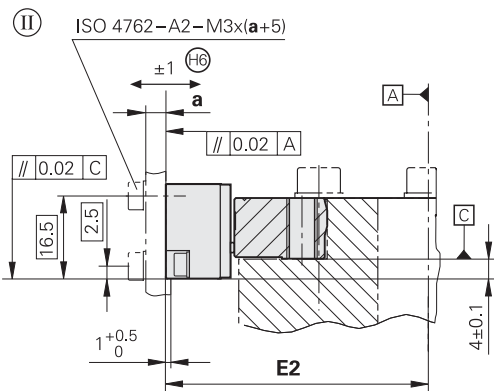
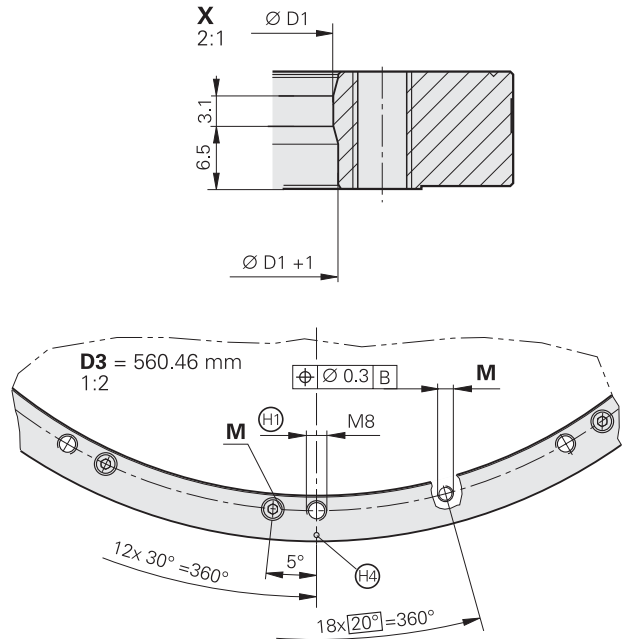
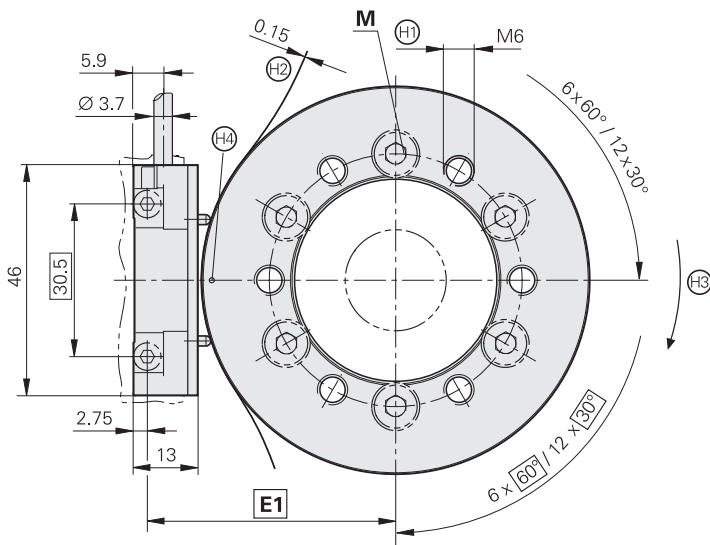
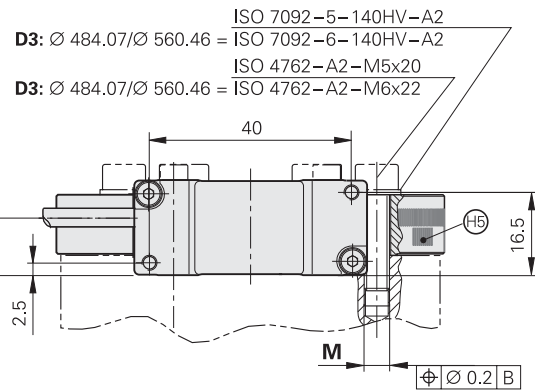
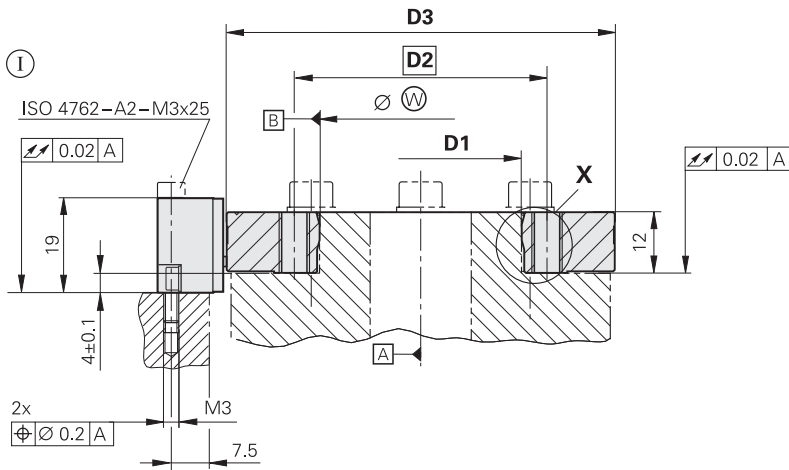

For CAD data go to [cad.heidenhain.de](http://cad.heidenhain.de)

mm  
Tolerancing ISO 8015  
ISO 2768 - m H  
< 6 mm: ±0.2 mm

D1	W	*)	D2	D3	E1	E2	M
Ø 40 -0.001/-0.005	Ø 40 +0.004	0.001	Ø 50	Ø 76.75	49.34	52.08	6x M5
Ø 70 -0.001/-0.005	Ø 70 +0.005	0.001	Ø 85	Ø 104.63	63.28	66.02	6x M5
Ø 80 -0.001/-0.005	Ø 80 +0.006	0.0015	Ø 95	Ø 127.64	74.78	77.52	6x M5
Ø 120 -0.001/-0.008	Ø 120 +0.008	0.002	Ø 140	Ø 178.55	100.24	102.98	6x M5
Ø 150 -0.001/-0.008	Ø 150 +0.008	0.002	Ø 165	Ø 208.89	115.41	118.15	6x M5
Ø 180 -0.001/-0.008	Ø 180 +0.010	0.003	Ø 200	Ø 254.93	138.43	141.17	6x M5
Ø 270 0/-0.01	Ø 270 +0.012	0.003	Ø 290	Ø 331.31	176.62	179.36	12x M5
Ø 425 0/-0.01	Ø 425 +0.015	0.006	Ø 445	Ø 484.07	253.00	255.74	12x M6
Ø 512 0/-0.015	Ø 512 +0.016	0.007	Ø 528	Ø 560.46	291.19	293.93	18x M6

\*) Roundness of mating diameter for shaft

# ERA 4480C

With protective cover

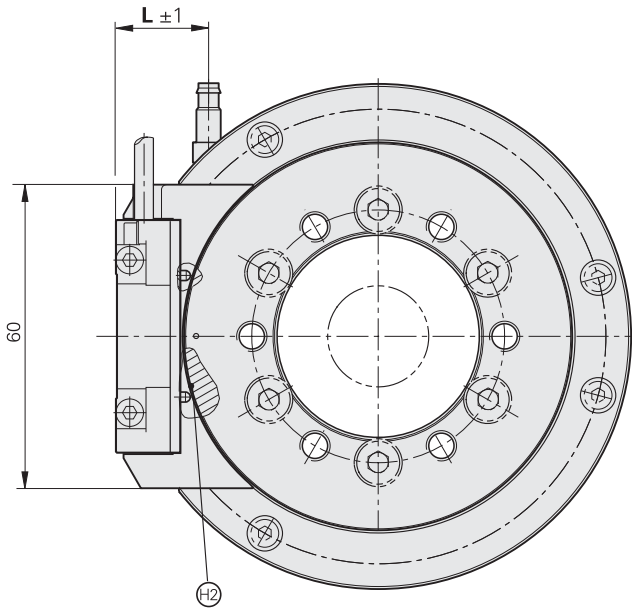
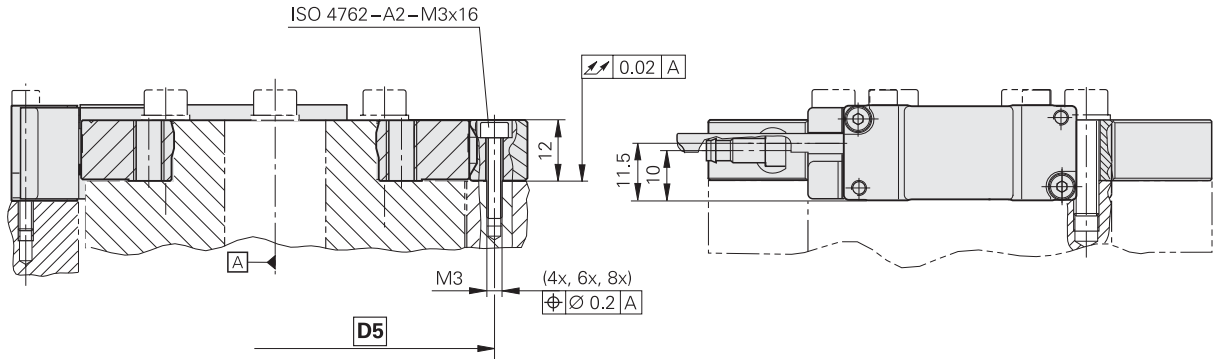

- ⊙, ⊕ = Mounting options
- M = Mounting screws
- ⊠ = Bearing
- ⊗ = Mating shaft
- ⊖ = Back-off thread
- ⊕ = Mounting clearance (spacer foil)
- ⊕ = Positive direction of rotation for output signals as per interface description
- ⊕ = Marker for reference mark, position tolerance with respect to reference mark ± 1.0 mm
- ⊕ = Reference mark
- ⊕ = Ensure adjustability of mounting surface for scanning head
- ⊕ = Eccentric bushing
- ⊕ = Holes required for fine adjustment
- ⊕ = Mounting clearance 0.15 mm (protective cover)

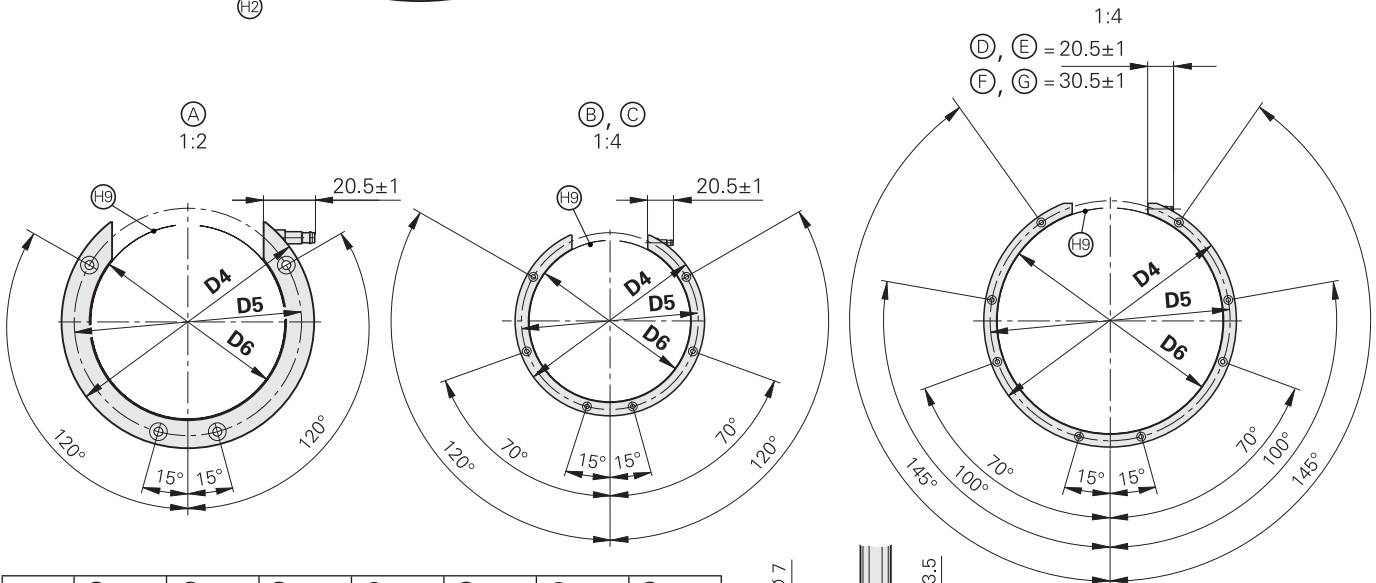

	A	B	C	D	E	F	G
<b>D3</b>	∅ 76.75	∅ 104.63	∅ 127.64	∅ 178.55	∅ 208.89	∅ 254.93	∅ 331.31
<b>D4</b>	∅ 100	∅ 127	∅ 150	∅ 200	∅ 232	∅ 278	∅ 354
<b>D5</b>	∅ 90	∅ 117	∅ 140	∅ 190	∅ 222	∅ 268	∅ 344
<b>D6</b>	∅ 77.2	∅ 105.2	∅ 128.2	∅ 179.1	∅ 209.4	∅ 255.6	∅ 332
<b>L</b>	18.6	16.5	15.5	14.5	13.2	12.7	12.1

For CAD data go to [cad.heidenhain.de](http://cad.heidenhain.de)

# ERA 4282 C

## Incremental angle encoder for high accuracy

- Steel scale drum for increased accuracy requirements
- Consists of scanning head and scale drum

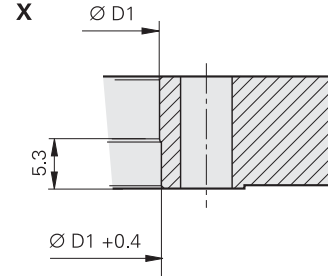
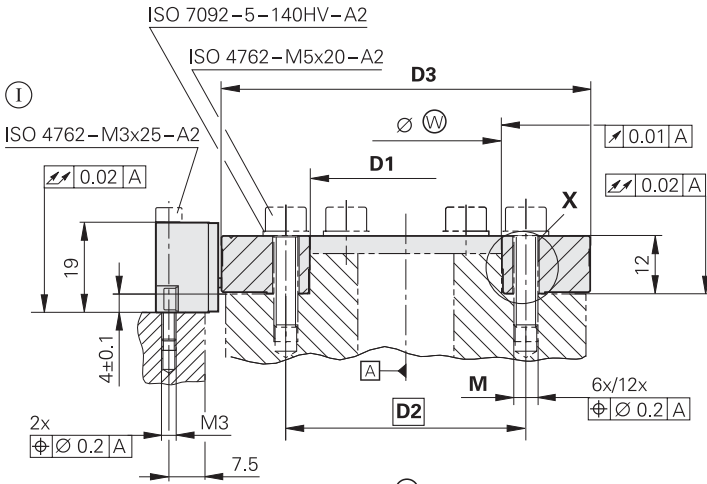

mm  
  
 Tolerancing ISO 8015  
 ISO 2768 - m H  
 < 6 mm: ±0.2 mm

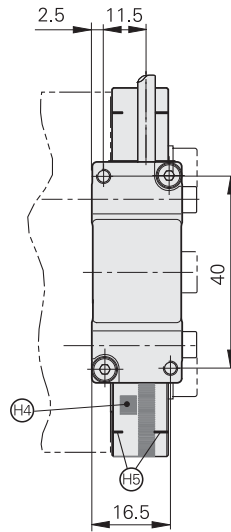
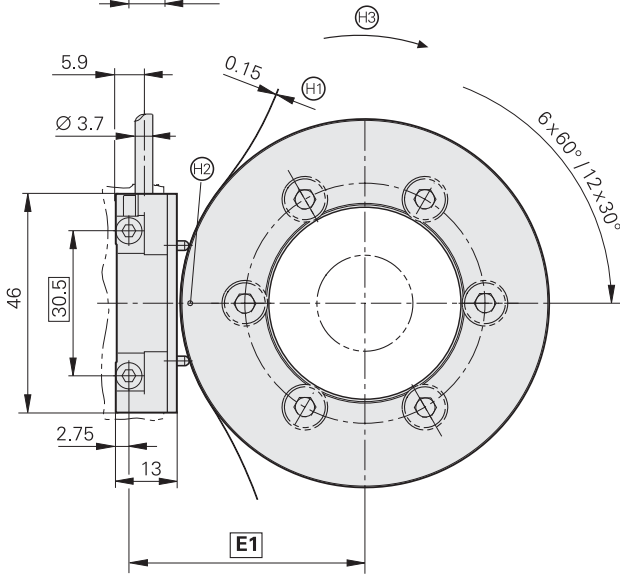

- ⊙, ⊕ = Mounting options
- ▭ = Bearing
- ⊕ = Mating shaft
- ⊕ = Mounting clearance (spacer foil)
- ⊕ = Marker for reference mark
- ⊕ = Positive direction of rotation for output signals as per interface description
- ⊕ = Reference mark
- ⊕ = Marks for drum centering (3 x 120°)
- ⊕ = Ensure adjustability of mounting surface for scanning head
- ⊕ = Eccentric bushing
- ⊕ = Mounting holes for fine adjustment (only for ERA 4280 scanning head)

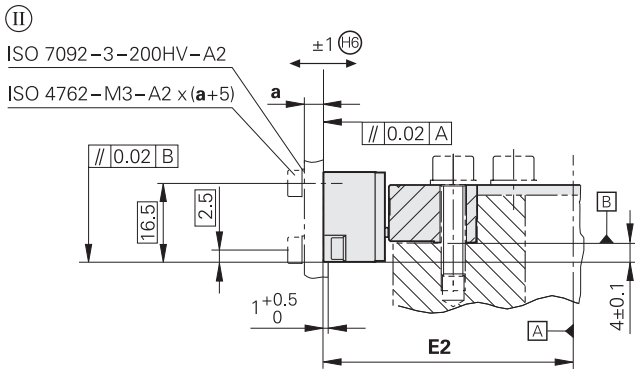

### Fine adjustment of the ERA 4280 scanning head

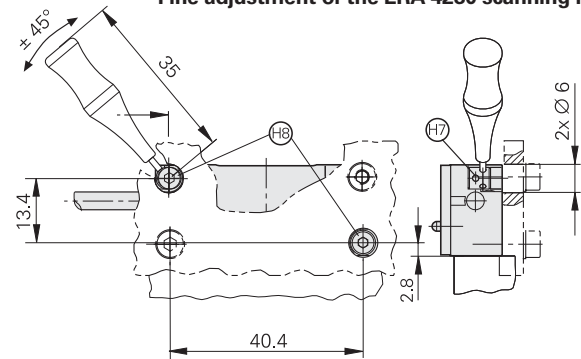

For CAD data go to [cad.heidenhain.de](http://cad.heidenhain.de)

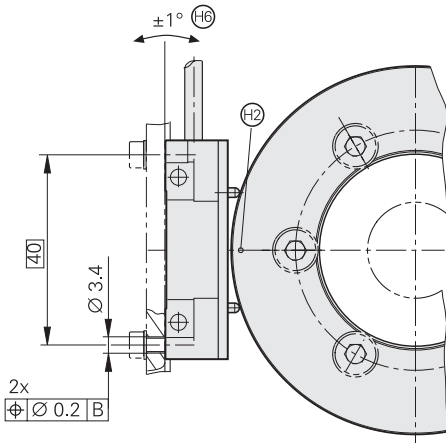

D1	⊕	D2	D3	E1	E2	M
Ø 40 +0.07/+0.05	Ø ≤ 40	Ø 50	Ø 76.75	49.34	52.08	M5 6x
Ø 70 +0.07/+0.05	Ø ≤ 70	Ø 85	Ø 104.63	63.28	66.02	M5 6x
Ø 80 +0.07/+0.05	Ø ≤ 80	Ø 95	Ø 127.64	74.78	77.52	M5 6x
Ø 120 +0.07/+0.05	Ø ≤ 120	Ø 140	Ø 178.55	100.24	102.98	M5 6x
Ø 150 +0.07/+0.05	Ø ≤ 150	Ø 165	Ø 208.89	115.41	118.15	M5 6x
Ø 180 +0.07/+0.05	Ø ≤ 180	Ø 200	Ø 254.93	138.43	141.17	M5 6x
Ø 185 +0.07/+0.05	Ø ≤ 185	Ø 197	Ø 208.89	115.41	118.15	M3 12x
Ø 210 +0.07/+0.05	Ø ≤ 210	Ø 230	Ø 254.93	138.43	141.17	M3 12x
Ø 270 +0.07/+0.05	Ø ≤ 270	Ø 290	Ø 331.31	176.62	179.36	M5 12x

<b>Scanning head</b>	<b>AK ERA 4280</b>
<b>Interface</b>	$\sim 1 V_{pp}$
Cutoff frequency -3 dB	$\geq 350$ kHz
<b>Electrical connection</b>	Cable 1 m, with M23 coupling (12-pin)
Cable length	$\leq 150$ m (with HEIDENHAIN cable)
Power supply	$5 V \pm 0.5 V$ DC
Current requirement	$< 100$ mA (without load)
<b>Vibration</b> 55 to 2000 Hz <b>Shock</b> 6 ms	$\leq 100$ m/s <sup>2</sup> (EN 60068-2-6) $\leq 500$ m/s <sup>2</sup> (EN 60068-2-27)
<b>Operating temperature</b>	-10 °C to 80 °C
<b>Weight</b>	Approx. 20 g (without cable)

<b>Scale drum</b>	<b>TTR ERA 4202 C</b>								
<b>Measuring standard</b> Grating period Coefficient of expansion	Steel drum 20 $\mu$ m $\alpha_{therm} \approx 10.5 \cdot 10^{-6} K^{-1}$								
<b>Signal periods</b>	12000	16384	20000	28000	32768	40000	32768	40000	52000
<b>Accuracy of graduation</b>	$\pm 4''$	$\pm 3''$	$\pm 2.5''$	$\pm 2''$	$\pm 1.9''$	$\pm 1.8''$	$\pm 1.9''$	$\pm 1.8''$	$\pm 1.7''$
<b>Position error per signal period</b> <sup>1)</sup>	$\pm 1.1''$	$\pm 0.8''$	$\pm 0.7''$	$\pm 0.5''$	$\pm 0.4''$	$\pm 0.4''$	$\pm 0.4''$	$\pm 0.4''$	$\pm 0.3''$
<b>Reference marks</b>	Distance-coded								
<b>Drum inside diameter*</b>	40 mm	70 mm	80 mm	120 mm	150 mm	180 mm	185 mm	210 mm	270 mm
<b>Drum outside diameter*</b>	76.75 mm	104.63 mm	127.64 mm	178.55 mm	208.89 mm	254.93 mm	208.89 mm	254.93 mm	331.31 mm
Mech. permissible speed	10000 min <sup>-1</sup>	8500 min <sup>-1</sup>	6250 min <sup>-1</sup>	4500 min <sup>-1</sup>	4250 min <sup>-1</sup>	3250 min <sup>-1</sup>	3250 min <sup>-1</sup>	3250 min <sup>-1</sup>	2500 min <sup>-1</sup>
Moment of inertia of rotor	$0.28 \cdot 10^{-3}$ kgm <sup>2</sup>	$0.83 \cdot 10^{-3}$ kgm <sup>2</sup>	$2.0 \cdot 10^{-3}$ kgm <sup>2</sup>	$7.1 \cdot 10^{-3}$ kgm <sup>2</sup>	$12 \cdot 10^{-3}$ kgm <sup>2</sup>	$28 \cdot 10^{-3}$ kgm <sup>2</sup>	$6.5 \cdot 10^{-3}$ kgm <sup>2</sup>	$20 \cdot 10^{-3}$ kgm <sup>2</sup>	$59 \cdot 10^{-3}$ kgm <sup>2</sup>
Permissible axial movement	$\leq \pm 0.5$ mm (scale drum relative to scanning head)								
<b>Protection</b> EN 60529	IP 00								
<b>Weight</b>	$\approx 0.30$ kg	$\approx 0.42$ kg	$\approx 0.70$ kg	$\approx 1.2$ kg	$\approx 1.5$ kg	$\approx 2.3$ kg	$\approx 0.66$ kg	$\approx 1.5$ kg	$\approx 2.6$ kg

\* Please select when ordering

<sup>1)</sup> The position error within one signal period and the accuracy of the graduation result together in the encoder-specific error; for additional error through mounting and the bearing of the measured shaft, see Measuring accuracy

# ERA 7000 series

Incremental angle encoder for high accuracy

- Steel scale tape for internal mounting
- Full-circle and segment versions, also for very large diameters
- Consists of scanning head and scale tape



ERA 7480



ERA 7481

<b>Scanning head</b>	<b>AK ERA 7480</b>
<b>Interface</b>	$\sim 1 V_{pp}$
Cutoff frequency -3 dB	$\geq 350$ kHz
<b>Electrical connection</b>	Cable 1 m, with M23 coupling (12-pin)
Cable length	$\leq 150$ m (with HEIDENHAIN cable)
Power supply	5 V DC $\pm 0.25$ V
Current requirement	$< 100$ mA (without load)
<b>Vibration</b> 55 to 2000 Hz <b>Shock</b> 6 ms	$\leq 200$ m/s <sup>2</sup> (EN 60068-2-6) $\leq 1000$ m/s <sup>2</sup> (EN 60068-2-27)
<b>Operating temperature</b>	-10 °C to 80 °C
<b>Weight</b>	Approx. 20 g (without cable)

<b>Scale Tape</b>	<b>MSB ERA 7400C</b> full circle version <b>MSB ERA 7401C</b> segment version			
<b>Measuring standard</b> Grating period Coefficient of expansion	Steel scale-tape with METALLUR graduation 40 $\mu$ m $\alpha_{therm} \approx 10.5 \cdot 10^{-6} K^{-1}$			
<b>Signal periods</b> <sup>1)</sup>	36000	45000	90000	
<b>Accuracy of the graduation</b> <sup>2)</sup>	$\pm 3.9''$	$\pm 3.2''$	$\pm 1.6''$	
<b>Position error per signal period</b> <sup>2)</sup>	$\pm 0.4''$	$\pm 0.3''$	$\pm 0.1''$	
<b>Accuracy of the scale tape</b>	$\pm 3$ $\mu$ m/m of tape length			
<b>Reference marks</b>	Distance-coded			
<b>Scale-slot diameter*</b>	Full circle	458.62 mm	573.20 mm	1146.10 mm
	Segment	$\geq 400$ mm		
Mech. permissible speed	$\leq 250$ min <sup>-1</sup>	$\leq 250$ min <sup>-1</sup>	$\leq 220$ min <sup>-1</sup>	
Permissible axial movement	$\leq 0.5$ mm (scale tape relative to scanning head)			
Permissible expansion coefficient of shaft	$\alpha_{therm} \approx 9 \cdot 10^{-6} K^{-1}$ to $12 \cdot 10^{-6} K^{-1}$			
<b>Protection</b> EN 60529	IP 00			
<b>Weight</b>	Approx. 30 g/m			

\* Please select when ordering

<sup>1)</sup> Applies to full-circle version; for segment versions depends on mating diameter and tape length

<sup>2)</sup> The accuracy of the graduation and the position error within one signal period result together in the encoder-specific error; for additional error through mounting and the bearing of the measured shaft, see *Measuring accuracy*

Other diameters and higher speeds available on request



# ERA 7000 series

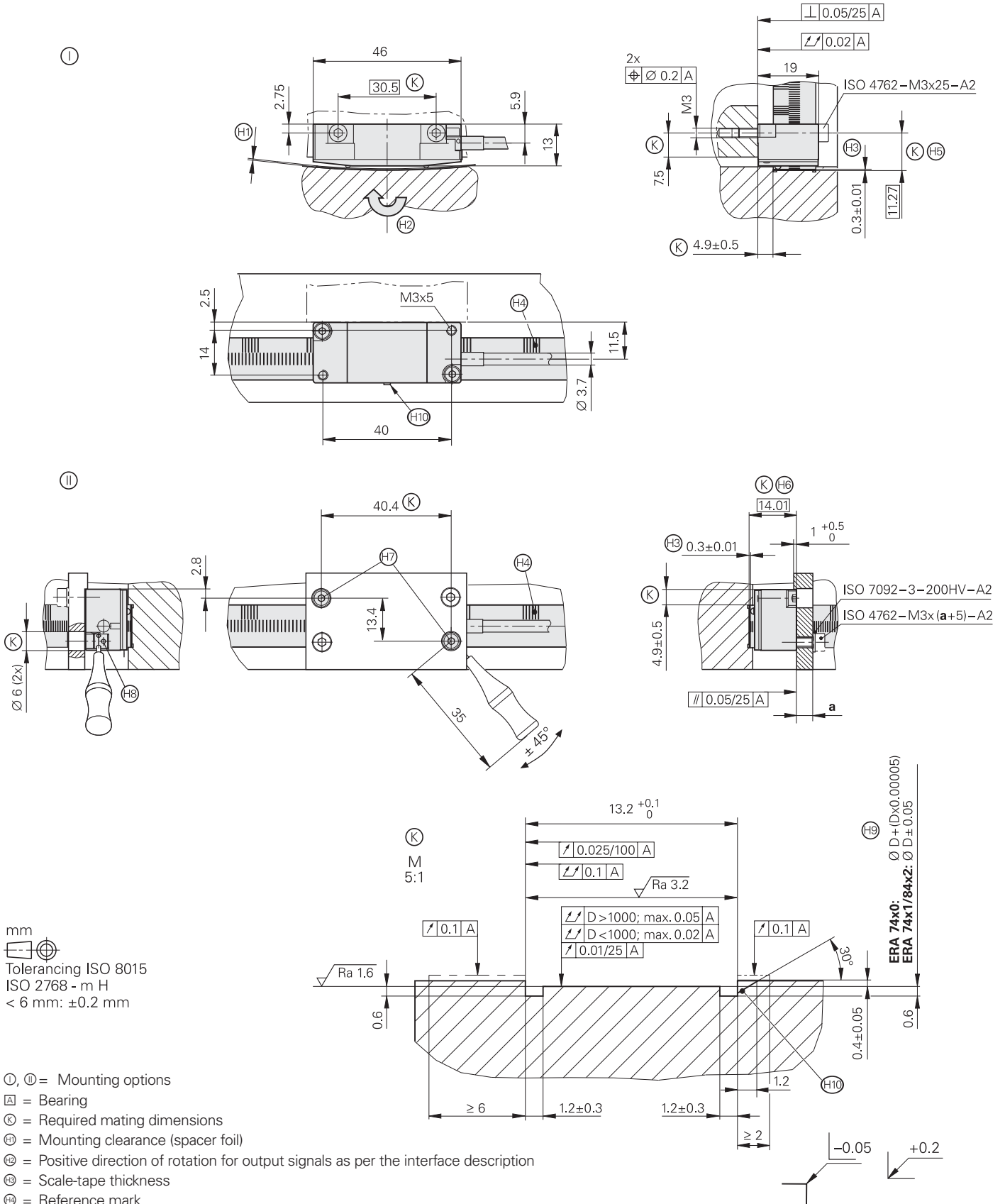

mm  
  
 Tolerancing ISO 8015  
 ISO 2768 - m H  
 < 6 mm:  $\pm 0.2$  mm

- ⓪, ① = Mounting options
- Ⓜ = Bearing
- Ⓚ = Required mating dimensions
- Ⓜ = Mounting clearance (spacer foil)
- Ⓜ = Positive direction of rotation for output signals as per the interface description
- Ⓜ = Scale-tape thickness
- Ⓜ = Reference mark
- Ⓜ = Distance between scale-tape slot floor and threaded mounting hole
- Ⓜ = Distance between scale-tape slot floor and scanning head's rear mounting surface
- Ⓜ = Holes required for fine adjustment
- Ⓜ = Eccentric bushing (Moiré setting)
- Ⓜ = Scale-tape slot floor  $\varnothing D$
- Ⓜ = Notch for removing the scale tape (b = 2 mm)

**ERA 74x1 scale tape (segment)**

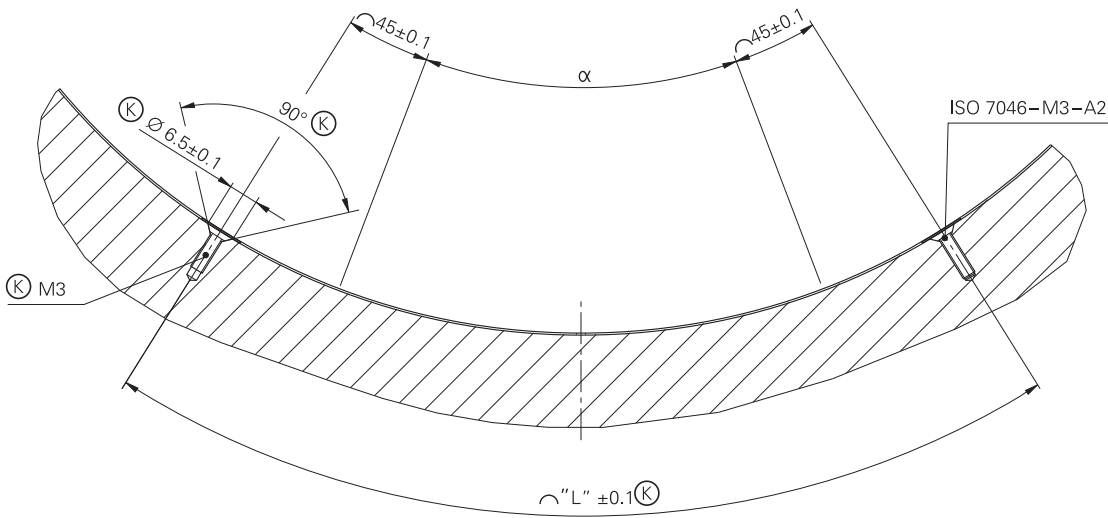
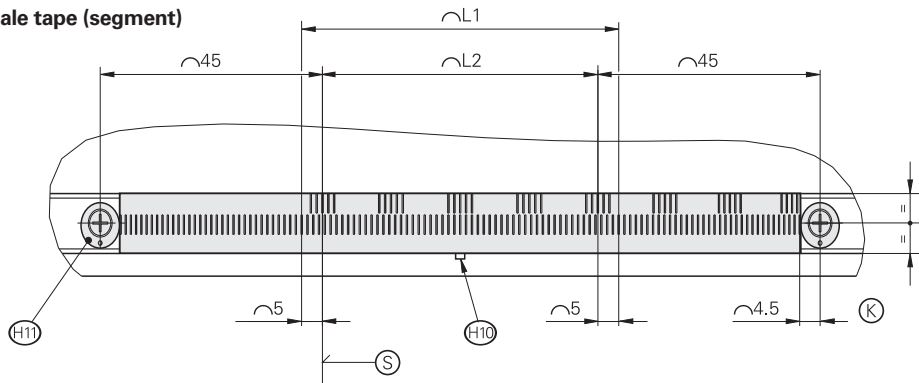

$$D = \frac{n \times 0.04 \times 0.9999}{\pi} + 0.3$$

$$\alpha = \frac{n \times 0.04 \times 0.9999}{(D - 0.3) \times \pi} \times 360^\circ$$

$$L2 = n \times 0.04 \times 0.9999$$

- Ⓚ = Required mating dimensions
- Ⓢ = Beginning of measurement
- Ⓜ = Notch for removing the scale tape (b = 2 mm)
- Ⓜ = Cam disk for tensioning the scale tape
- ⌒ = Length of the arc in the stress-free zone, pay attention to the scale-tape thickness
- ⌒L = Position of the threaded holes
- ⌒L1 = Traverse path
- ⌒L2 = Measuring range in the arc

- n = Line count
- D = Mating diameter
- α = Measuring range in degrees (segment angle)
- π = 3.14159...

# ERA 8000 series

Incremental angle encoder for high accuracy

- Steel scale tape for external mounting
- Full-circle and segment versions, also for very large diameters
- Consists of scanning head and scale tape



ERA 8480 full-circle version



ERA 8481 segment version,  
scale tape secured with tensioning elements



ERA 8482 segment version,  
scale tape without tensioning elements

<b>Scanning head</b>	<b>AK ERA 8480</b>
<b>Interface</b>	$\sim 1 V_{pp}$
Cutoff frequency -3 dB	$\geq 350$ kHz
<b>Electrical connection</b>	Cable 1 m, with M23 coupling (12-pin)
Cable length	$\leq 150$ m (with HEIDENHAIN cable)
Power supply	5 V DC $\pm 0.25$ V
Current requirement	$< 100$ mA (without load)
<b>Vibration</b> 55 to 2000 Hz <b>Shock</b> 6 ms	$\leq 200$ m/s <sup>2</sup> (EN 60068-2-6) $\leq 1000$ m/s <sup>2</sup> (EN 60068-2-27)
<b>Operating temperature</b>	-10 °C to 80 °C
<b>Weight</b>	Approx. 20 g (without cable)

<b>Scale Tape</b>	<b>MSB ERA 8400C</b> full circle version <b>MSB ERA 8401C</b> segment version with tensioning elements <b>MSB ERA 8402C</b> segment version without tensioning elements			
<b>Measuring standard</b> Grating period Coefficient of expansion	Steel scale-tape with METALLUR graduation 40 $\mu$ m $\alpha_{therm} \approx 10.5 \cdot 10^{-6} K^{-1}$			
<b>Signal periods</b> <sup>1)</sup>	36000	45000	90000	
<b>Accuracy of the graduation</b> <sup>2)</sup>	$\pm 4.7''$	$\pm 3.9''$	$\pm 1.9''$	
<b>Position error per signal period</b> <sup>2)</sup>	$\pm 0.4''$	$\pm 0.3''$	$\pm 0.1''$	
<b>Accuracy of the scale tape</b>	$\pm 3$ $\mu$ m/m of tape length			
<b>Reference marks</b>	Distance-coded			
<b>Scale-slot diameter*</b>	Full circle	458.11 mm	572.72 mm	1145.73 mm
	Segment	$\geq 400$ mm		
Mech. permissible speed	$\leq 50$ min <sup>-1</sup>	$\leq 50$ min <sup>-1</sup>	$\leq 45$ min <sup>-1</sup>	
Permissible axial movement	$\leq 0.5$ mm (scale tape relative to scanning head)			
Permissible expansion coefficient of shaft	$\alpha_{therm} \approx 9 \cdot 10^{-6} K^{-1}$ to $12 \cdot 10^{-6} K^{-1}$			
<b>Protection</b> EN 60529	IP 00			
<b>Weight</b>	Approx. 30 g/m			

\* Please select when ordering

<sup>1)</sup> Applies to full-circle version; for segment versions depends on mating diameter and tape length

<sup>2)</sup> The accuracy of the graduation and the position error within one signal period result together in the encoder-specific error; for additional error through mounting and the bearing of the measured shaft, see *Measuring accuracy*

Other diameters and higher speeds available on request

# ERA 8000 series

①

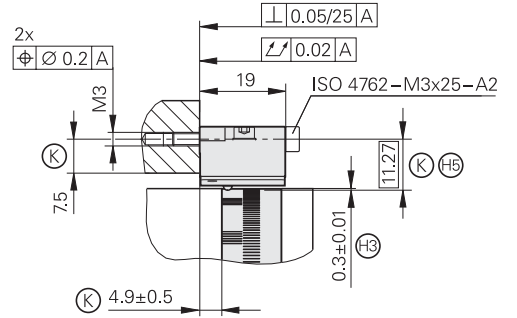
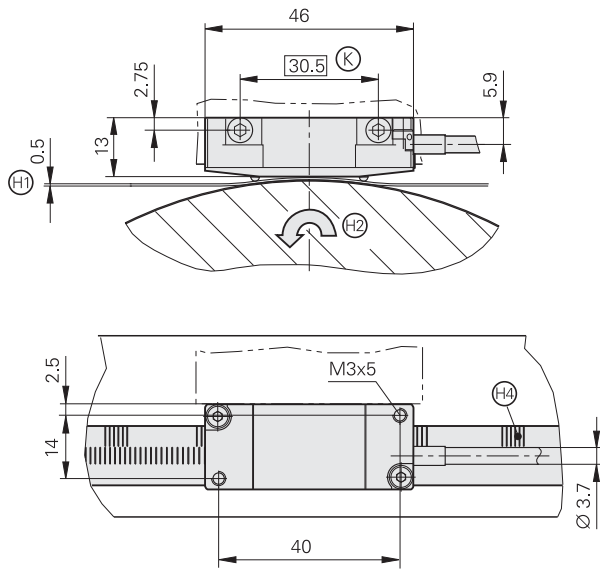

②

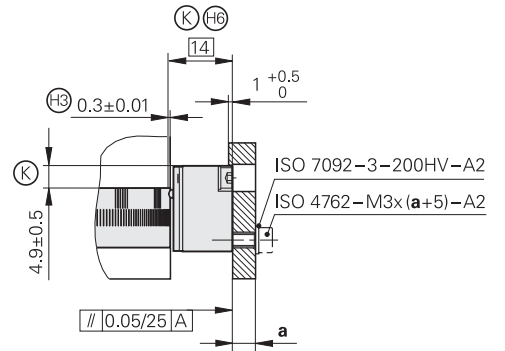
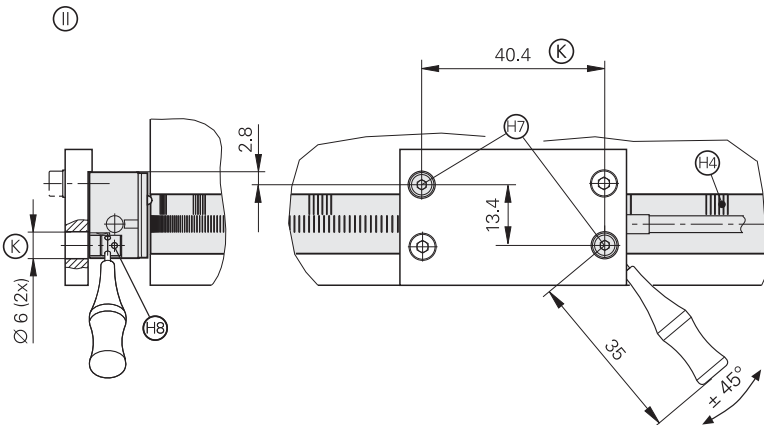

mm  
 Tolerancing ISO 8015  
 ISO 2768 - m H  
 < 6 mm: ±0.2 mm

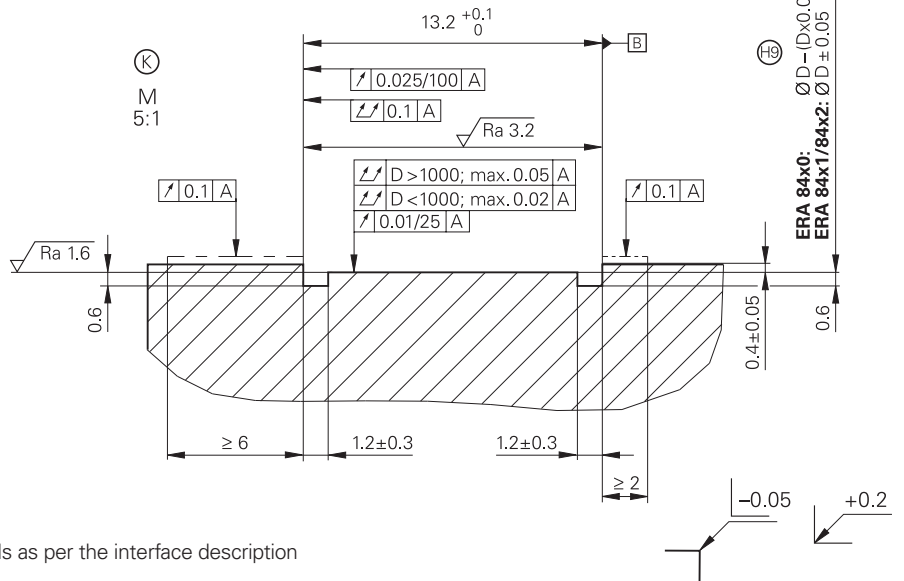

ERA 84x0: Ø D - (D×0.00005)  
 ERA 84x1/84x2: Ø D ± 0.05

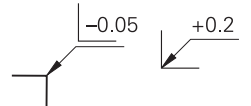

- ①, ② = Mounting options
- ▭ = Bearing
- ⊕ = Required mating dimensions
- ⊙ = Beginning of measurement
- ⊕ = Mounting clearance (spacer foil)
- ⊕ = Positive direction of rotation for output signals as per the interface description
- ⊕ = Scale-tape thickness
- ⊕ = Reference mark
- ⊕ = Distance between floor of scale-tape slot and threaded mounting hole
- ⊕ = Distance between scale-tape slot floor and scanning head's rear mounting surface
- ⊕ = Holes required for fine adjustment
- ⊕ = Eccentric bushing (Moiré setting)
- ⊕ = Scale-tape slot floor Ø D
- ⊕ = Floor of pocket is ferromagnetic for fixing the tensioning cleat
- ⊕ = Length of the chamfer >60 mm

**ERA 84x0 scale tape (full circle)**

Ⓚ  
M  
1:2

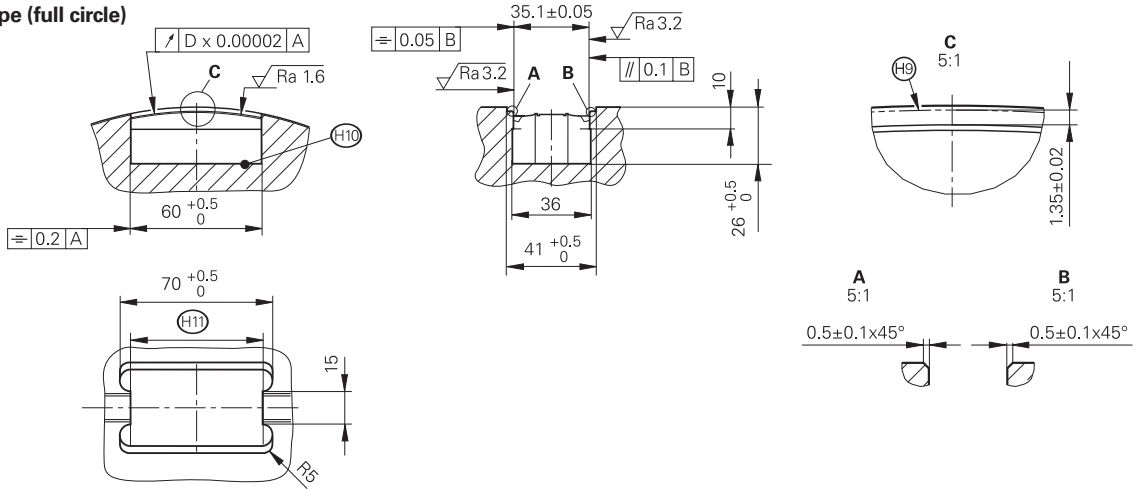

**ERA 84x1 scale tape (segment)**

Ⓚ  
M  
1:2

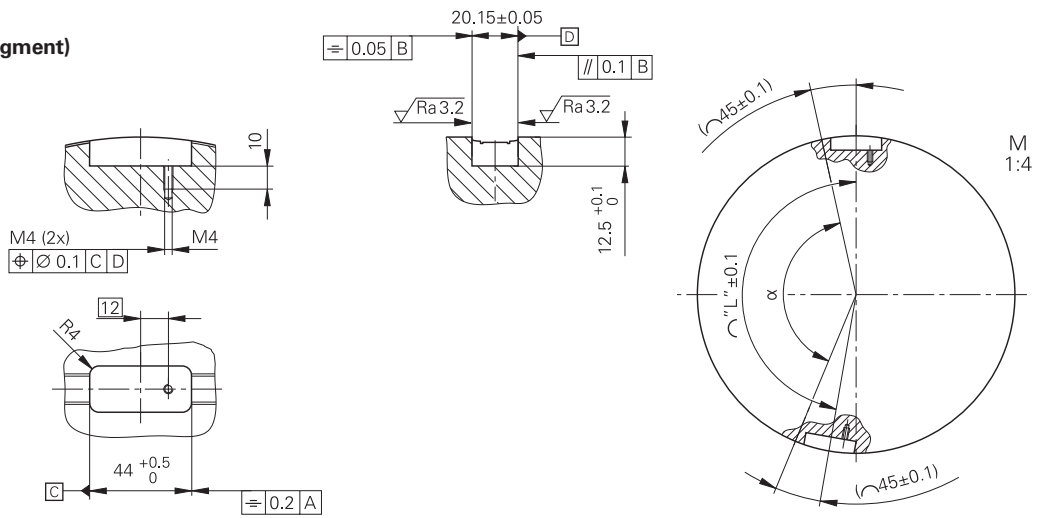

**ERA 84x2 scale tape (segment)**

M  
1:2

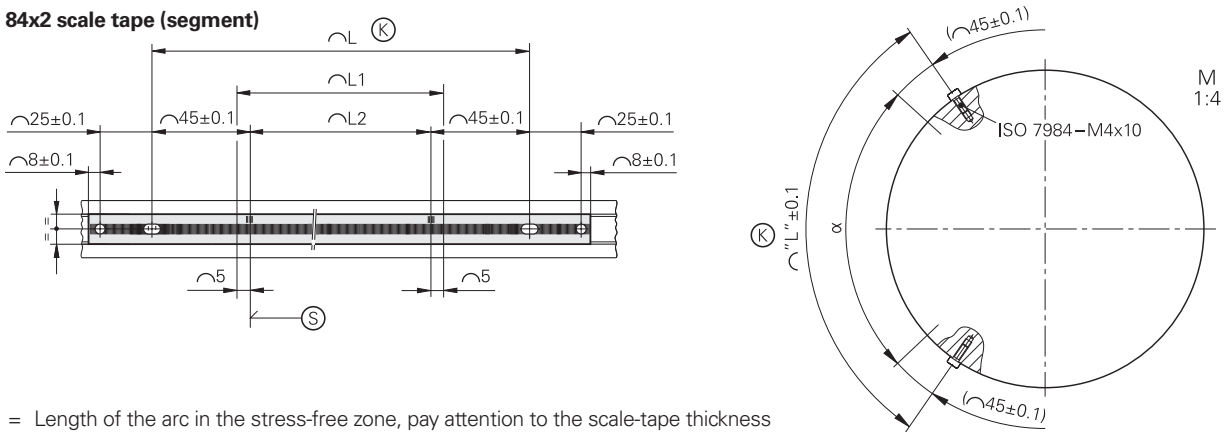

- ⌒ = Length of the arc in the stress-free zone, pay attention to the scale-tape thickness
- ⌒L = Position of the two end-piece openings or threaded mounting holes
- ⌒L1 = Traverse path
- ⌒L2 = Measuring range in the arc

- n = Line count
- D = Slot-floor diameter
- α = Measuring range in degrees (segment angle)
- π = 3.14159...

$$D = \frac{n \times 0.04 \times 1.0001}{\pi} - 0.3$$

$$\alpha = \frac{n \times 0.04 \times 1.0001}{(D + 0.3) \times \pi} \times 360^\circ$$

$$L2 = n \times 0.04 \times 1.0001$$

# Interfaces

## Incremental signals $\sim 1 V_{PP}$

HEIDENHAIN encoders with  $\sim 1 V_{PP}$  interface provide highly interpolable voltage signals.







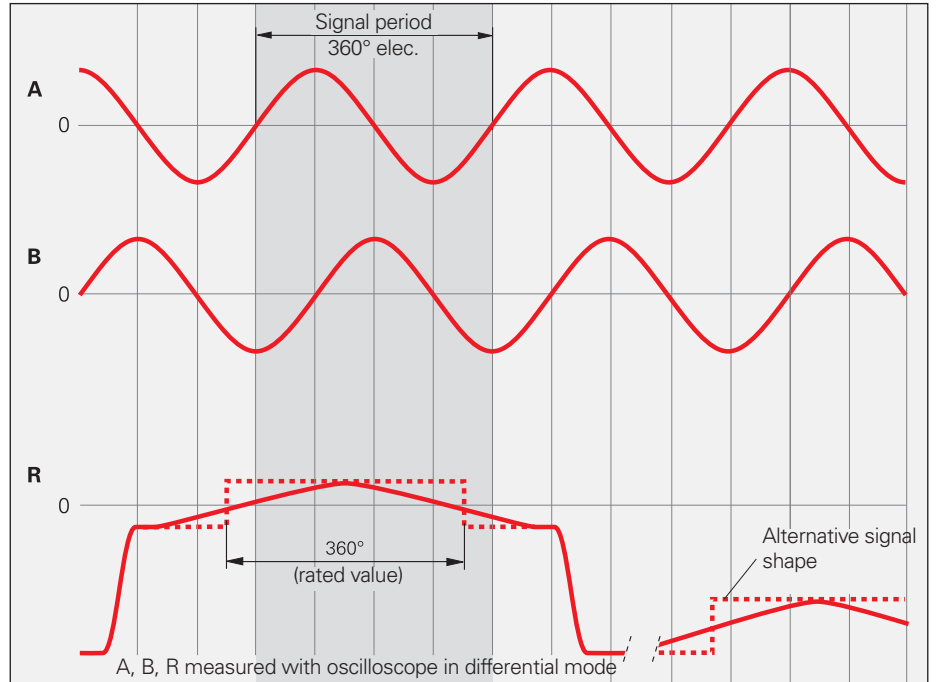

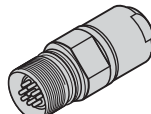
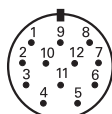

The sinusoidal **incremental signals** A and B are phase-shifted by  $90^\circ$  elec. and have amplitudes of typically  $1 V_{PP}$ . The illustrated sequence of output signals—with B lagging A—applies for the direction of motion shown in the dimension drawing.

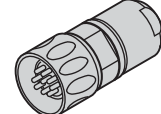
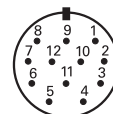
The **reference mark signal** R has an unambiguous assignment to the incremental signals. The output signal might be somewhat lower next to the reference mark.

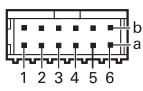
Comprehensive descriptions of all available interfaces as well as general electrical information are included in the *Interfaces for HEIDENHAIN Encoders* catalog.

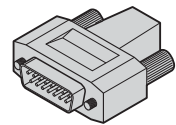
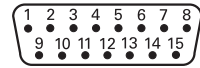

### Pin layout

<b>12-pin coupling M23</b>   					<b>12-pin connector M23</b>   								
<b>12-pin PCB connector</b> on ERP 880  					<b>15-pin D-sub connector</b>   								
	Power supply				Incremental signals						Other signals		
	12	2	10	11	5	6	8	1	3	4	9	7	/
	2a	2b	1a	1b	6b	6a	5b	5a	4b	4a	3b	3a	/
	4	12	2	10	1	9	3	11	14	7	5/6/8	13	15
	$U_P$	Sensor $U_P$	0V	Sensor 0V	A+	A-	B+	B-	R+ <sup>1)</sup>	R- <sup>1)</sup>	Vacant	Vacant	Vacant
	Brown/ Green	Blue	White/ Green	White	Brown	Green	Gray	Pink	Red	Black	/	Violet	Yellow

**Cable shield** connected to housing;  $U_P$  = Power supply voltage

**Sensor:** The sensor line is connected in the encoder (ERO 6x80: in the connector) with the corresponding power line.

Vacant pins or wires must not be used!

<sup>1)</sup> ERP 4080/ERP 8080: Vacant



# Incremental signals $\square$ TTL

HEIDENHAIN encoders with  $\square$ TTL interface incorporate electronics that digitize sinusoidal scanning signals with or without interpolation.

The **incremental signals** are transmitted as the square-wave pulse trains  $U_{a1}$  and  $U_{a2}$ , phase-shifted by  $90^\circ$  elec. The **reference mark signal** consists of one or more reference pulses  $U_{a0}$ , which are gated with the incremental signals. In addition, the integrated electronics produce their **inverted signals**  $\overline{U_{a1}}$ ,  $\overline{U_{a2}}$  and  $\overline{U_{a0}}$  for noise-proof transmission. The illustrated sequence of output signals—with  $U_{a2}$  lagging  $U_{a1}$ —applies to the direction of motion shown in the dimension drawing.

The **fault detection signal**  $\overline{U_{aS}}$  indicates fault conditions such as an interruption in the supply lines, failure of the light source, etc.

The distance between two successive edges of the incremental signals  $U_{a1}$  and  $U_{a2}$  through 1-fold, 2-fold or 4-fold evaluation is one **measuring step**.

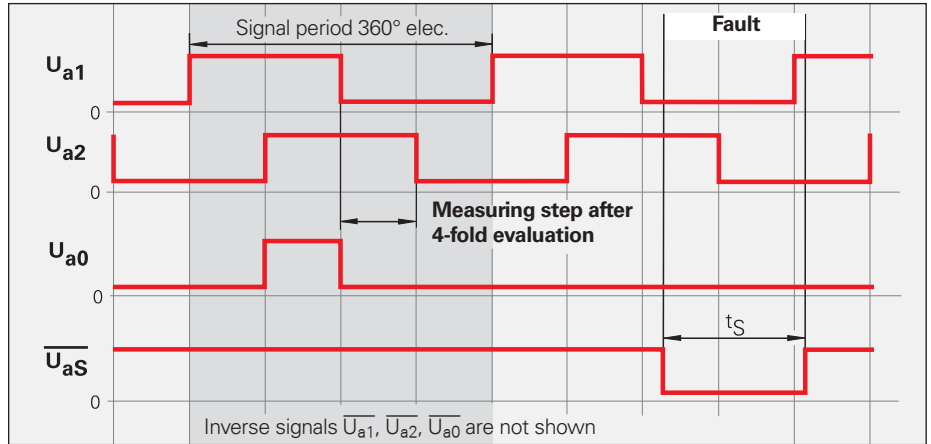

Comprehensive descriptions of all available interfaces as well as general electrical information are included in the *Interfaces for HEIDENHAIN Encoders* catalog.

## Pin layout

15-pin D-sub connector					15-pin D-sub connector with integrated interface electronics									
	Voltage supply				Incremental signals						Other signals			
	4	12	2	10	1	9	3	11	14	7	13	5/6/8	15	
	$U_P$	Sensor $U_P$	0V	Sensor 0V	$U_{a1}$	$\overline{U_{a1}}$	$U_{a2}$	$\overline{U_{a2}}$	$U_{a0}$	$\overline{U_{a0}}$	$\overline{U_{aS}}$	Vacant	Vacant <sup>1)</sup>	
	Brown/ Green	Blue	White/ Green	White	Brown	Green	Gray	Pink	Red	Black	Violet	/	Yellow	

**Cable shield** connected to housing;  $U_P$  = Power supply voltage  
**Sensor:** The sensor line is connected in the encoder (*ERO 6x70*: in the connector) with the corresponding power line.  
 Vacant pins or wires must not be used!

<sup>1)</sup> **ERO 6x70:** TTL/11  $\mu A_{PP}$  switchover for PWT, otherwise not used

# Cables and connecting elements

## General information

**Connector insulated:** Connecting element with coupling ring; available with male or female contacts.

Symbols  

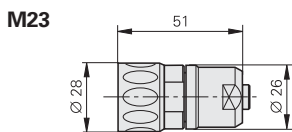

**Coupling insulated:** Connecting element with external thread; available with male or female contacts.

Symbols  

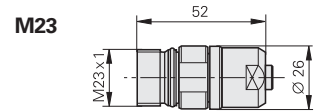

**Mounted coupling with central fastening**

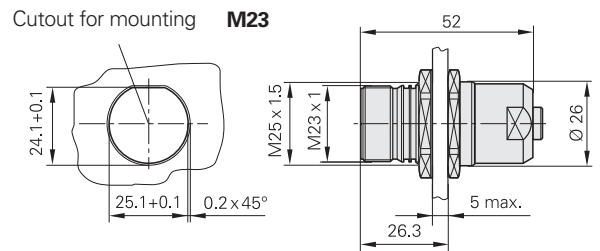

**Mounted coupling with flange**

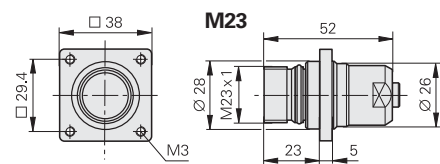

**Flange socket:** Permanently mounted on the encoder or a housing, with external thread (like the coupling), and available with male or female contacts.

Symbols  

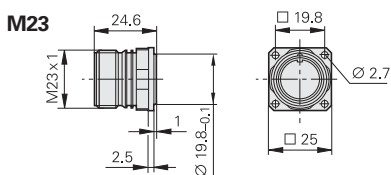



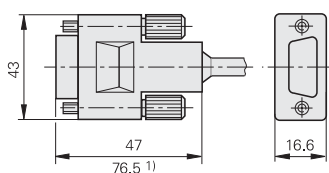

**D-sub connector:** For HEIDENHAIN controls, counters and IK absolute value cards.

Symbols  



<sup>1)</sup> With integrated interpolation electronics

The pins on connectors are **numbered** in the direction opposite to those on couplings or flange sockets, regardless of whether the connecting elements have

male contacts or    
female contacts.  











When engaged, the connections are **protected** to IP 67 (D-sub connector: IP 50; EN 60529). When not engaged, there is no protection.

**Accessories for flange sockets and M23 mounted couplings**

**Bell seal**  
ID 266526-01



**Threaded metal dust cap**  
ID 219926-01

# Connecting cables

		12-pin M23	
<b>PUR connecting cable</b> [6(2 × 0.19 mm <sup>2</sup> ); A <sub>P</sub> = 0.19 mm <sup>2</sup> ]			
<b>PUR connecting cable</b> [4(2 × 0.14 mm <sup>2</sup> ) + (4 × 0.5 mm <sup>2</sup> ); A <sub>P</sub> = 0.5 mm <sup>2</sup> ]		∅ 8 mm	∅ 6 mm <sup>1)</sup>
<b>Complete</b> with connector (female) and coupling (male)		298401-xx	–
<b>Complete</b> with connector (female) and connector (male)		298399-xx	–
<b>Complete</b> with connector (female) and D-sub connector (female) for IK 220/ND 780		310199-xx	–
<b>Complete</b> with connector (female) and D-sub connector (male) for IK 115/IK 215/ND 280/ND 287/EIB 741		310196-xx	–
With <b>one connector (female)</b>		309777-xx	–
<b>Complete</b> with D-sub connector (female) and M23 connector (male)		331693-xx	355215-xx
With <b>one</b> D-sub connector (female)		332433-xx	355209-xx
<b>Complete</b> with D-sub connectors (female and male)		335074-xx	355186-xx
<b>Complete</b> with D-sub connectors (female and female) and pin layout for IK 220/ND 780		335077-xx	349687-xx
<b>Cable only</b>		816317-xx	816323-xx
<b>Output cable</b> for ERP 880	PUR [4(2 × 0.05) + (4 × 0.14)] mm <sup>2</sup> ; A <sub>P</sub> = 0.14 mm <sup>2</sup>	∅ 4.5 mm	
With <b>one</b> PCB connector, 12-pin	 Length 1 m	372164-01	

<sup>1)</sup> Cable length for ∅ 6 mm max. 9 m  
A<sub>P</sub>: Cross section of power supply lines

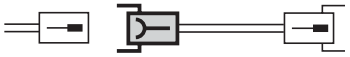
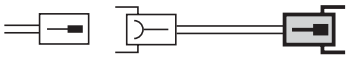
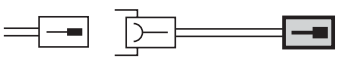
# Connecting elements

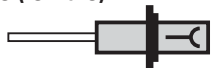
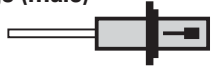
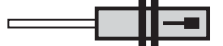
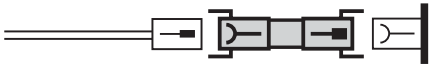
			12-pin M23
<b>Mating element on connecting cable to connecting element on encoder</b>	<b>Connector (female)</b> 	For cable Ø 8 mm	291697-05
<b>Connector</b> for connection to subsequent electronics	<b>Connector (male)</b> 	For cable Ø 8 mm Ø 6 mm	291697-08 291697-07
<b>Coupling on encoder cable or connecting cable</b>	<b>Coupling (male)</b> 	For cable Ø 3.7 mm Ø 4.5 mm Ø 6 mm Ø 8 mm	291698-14 291698-14 291698-03 291698-04
<b>Flange socket</b> for mounting on the subsequent electronics	<b>Flange socket (female)</b> 		315892-08
<b>Mounted couplings</b>	<b>With flange (female)</b> 	Ø 6 mm Ø 8 mm	291698-17 291698-07
	<b>With flange (male)</b> 	Ø 6 mm Ø 8 mm	291698-08 291698-31
	<b>With central fastener (male)</b> 	Ø 6 mm to 10 mm	741045-01
<b>Adapter <math>\sim 1V_{PP}/11\mu A_{PP}</math></b> For converting the $1V_{PP}$ signals to $11\mu A_{PP}$ ; M23 connector (female, 12-pin) and M23 connector (male, 9-pin)			364914-01

# Diagnostic and testing equipment

HEIDENHAIN encoders are provided with all information necessary for commissioning, monitoring and diagnostics. The type of available information depends on whether the encoder is incremental or absolute and which interface is used.

Incremental encoders mainly have 1 V<sub>PP</sub> TTL or HTL interfaces. TTL and HTL encoders monitor their signal amplitudes internally and generate a simple fault detection signal. With 1 V<sub>PP</sub> signals, the analysis of output signals is possible only in external test devices or through computation in the subsequent electronics (analog diagnostics interface).

HEIDENHAIN offers the appropriate PWM inspection devices and PWT test devices for encoder analysis. There are two types of diagnostics, depending on how they are integrated:

- Encoder diagnostics: The encoder is connected directly to the test or inspection device. This makes a comprehensive analysis of encoder functions possible.
- Diagnostics in the control loop: The PWM phase meter is looped into the closed control loop (e.g. through a suitable testing adapter). This makes a real-time diagnosis of the machine or system possible during operation. The functions depend on the interface.

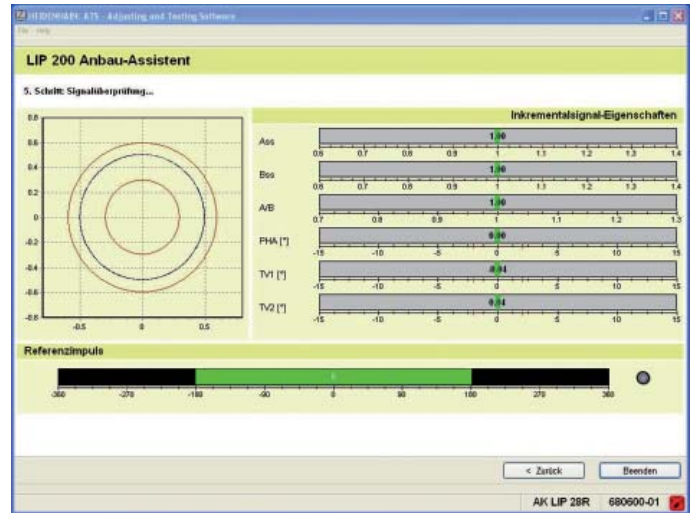

Commissioning using PWM 20 and ATS software

### PWM 20

Together with the ATS adjusting and testing software, the PWM 20 phase angle measuring unit serves for diagnosis and adjustment of HEIDENHAIN encoders.



For more information, see the *PWM 20, ATS Software* Product Information document.

	PWM 20
<b>Encoder input</b>	<ul style="list-style-type: none"> <li>• EnDat 2.1 or EnDat 2.2 (absolute value with/without incremental signals)</li> <li>• DRIVE-CLiQ</li> <li>• Fanuc serial interface</li> <li>• Mitsubishi high speed interface</li> <li>• Yaskawa serial interface</li> <li>• SSI</li> <li>• 1 V<sub>PP</sub>/TTL/11 μA<sub>PP</sub></li> </ul>
<b>Interface</b>	USB 2.0
<b>Voltage supply</b>	100 V to 240 V AC or 24 V DC
<b>Dimensions</b>	258 mm x 154 mm x 55 mm

	ATS
<b>Languages</b>	Choice between English and German
<b>Functions</b>	<ul style="list-style-type: none"> <li>• Position display</li> <li>• Connection dialog</li> <li>• Diagnostics</li> <li>• Mounting wizard for EBI/ECI/EQI, LIP 200, LIC 4000 and others</li> <li>• Additional functions (if supported by the encoder)</li> <li>• Memory contents</li> </ul>
<b>System requirements and recommendations</b>	PC (dual-core processor, > 2 GHz) RAM > 2 GB Windows operating systems XP, Vista, 7 (32-bit/64-bit), 8 200 MB free space on hard disk

DRIVE-CLiQ is a registered trademark of Siemens Aktiengesellschaft

The **PWM 9** is a universal measuring device for checking and adjusting HEIDENHAIN incremental encoders. Expansion modules are available for checking the various types of encoder signals. The values can be read on an LCD monitor. Soft keys provide ease of operation.



	PWM 9
<b>Inputs</b>	Expansion modules (interface boards) for 11 μA <sub>PP</sub> ; 1 V <sub>PP</sub> ; TTL; HTL; EnDat*/SSI*/commutation signals *No display of position values or parameters
<b>Functions</b>	<ul style="list-style-type: none"> <li>• <b>Measures</b> signal amplitudes, current consumption, operating voltage, scanning frequency</li> <li>• <b>Graphic display</b> of incremental signals (amplitudes, phase angle and on-off ratio) and the length and width of the reference signal</li> <li>• <b>Display symbols</b> for the reference mark, fault detection signal, counting direction</li> <li>• <b>Universal counter</b>, interpolation selectable from single to 1024-fold</li> <li>• <b>Adjustment support</b> for exposed linear encoders</li> </ul>
<b>Outputs</b>	<ul style="list-style-type: none"> <li>• Inputs are connected through to the subsequent electronics</li> <li>• BNC sockets for connection to an oscilloscope</li> </ul>
<b>Voltage supply</b>	10 V to 30 V DC, max. 15 W
<b>Dimensions</b>	150 mm x 205 mm x 96 mm

The **PWT** is a simple adjusting aid for HEIDENHAIN incremental encoders. In a small LCD window, the signals are shown as bar charts with reference to their tolerance limits.



	PWT 10	PWT 17	PWT 18
<b>Encoder input</b>	~ 11 $\mu$ A <sub>PP</sub>	□TTL	~ 1 V <sub>PP</sub>
<b>Functions</b>	Measurement of signal amplitude Wave-form tolerance Amplitude and position of the reference mark signal		
<b>Voltage supply</b>	Via power supply unit (included)		
<b>Dimensions</b>	114 mm x 64 mm x 29 mm		

The **APE 381** interface electronics unit is necessary in order to connect PWM/PWT units to encoders with signal-error compensation. The APE 381 deactivates the signal-error compensation integrated in the scanning head, permitting evaluation of the uncompensated 1 V<sub>PP</sub> output signals of the encoder.



	APE 381
<b>Encoder input</b>	~ 1 V <sub>PP</sub> (signals are connected through)
<b>Design</b>	Cable with D-sub connector
<b>Function</b>	Switch-off of the signal-error compensation integrated in the scanning head
<b>Power supply</b>	Via subsequent electronics



# Interface electronics

Interface electronics from HEIDENHAIN adapt the encoder signals to the interface of the subsequent electronics. They are used when the subsequent electronics cannot directly process the output signals from HEIDENHAIN encoders, or if additional interpolation of the signals is necessary.

## Input signals of the interface electronics

Interface electronics from HEIDENHAIN can be connected to encoders with sinusoidal signals of 1 V<sub>PP</sub> (voltage signals) or 11 μA<sub>PP</sub> (current signals). Encoders with the serial interfaces EnDat or SSI can also be connected to various interface electronics.

## Output signals of the interface electronics

Interface electronics with the following interfaces to the subsequent electronics are available:

- TTL square-wave pulse trains
- EnDat 2.2
- DRIVE-CLiQ
- Fanuc serial interface
- Mitsubishi high speed interface
- Yaskawa serial interface
- Profibus

## Interpolation of the sinusoidal input signals

In addition to being converted, the sinusoidal encoder signals are also interpolated in the interface electronics. This permits finer measuring steps and, as a result, higher control quality and better positioning behavior.

## Formation of a position value

Some interface electronics have an integrated counting function. Starting from the last reference point set, an absolute position value is formed when the reference mark is traversed, and is transferred to the subsequent electronics.

## Box design



## Plug design



## Version for integration



## Top-hat rail design



Outputs		Inputs		Design – degree of protection	Interpolation <sup>1)</sup> or subdivision	Type	
Interface	Qty.	Interface	Qty.				
□TTL	1	~ 1 V <sub>PP</sub>	1	Box design – IP 65	5/10-fold	<b>IBV 101</b>	
					20/25/50/100-fold	<b>IBV 102</b>	
					Without interpolation	<b>IBV 600</b>	
					25/50/100/200/400-fold	<b>IBV 660B</b>	
				Plug design – IP 40	5/10/20/25/50/100-fold	<b>APE 371</b>	
				Version for integration – IP 00	5/10-fold	<b>IDP 181</b>	
		20/25/50/100-fold	<b>IDP 182</b>				
		~ 11 μA <sub>PP</sub>	1	Box design – IP 65	1	5/10-fold	<b>EXE 101</b>
						20/25/50/100-fold	<b>EXE 102</b>
						Without/5-fold	<b>EXE 602E</b>
25/50/100/200/400-fold	<b>EXE 660B</b>						
Version for integration – IP 00	5-fold	<b>IDP 101</b>					
	□TTL/ ~ 1 V <sub>PP</sub> Adjustable	~ 1 V <sub>PP</sub>	1	Box design – IP 65	2-fold	<b>IBV 6072</b>	
5/10-fold					<b>IBV 6172</b>		
5/10-fold and 20/25/50/100-fold					<b>IBV 6272</b>		
EnDat 2.2	1	~ 1 V <sub>PP</sub>	1	Box design – IP 65	≤ 16384-fold subdivision	<b>EIB 192</b>	
				Plug design – IP 40	≤ 16384-fold subdivision	<b>EIB 392</b>	
			2	Box design – IP 65	≤ 16384-fold subdivision	<b>EIB 1512</b>	
DRIVE-CLiQ	1	EnDat 2.2	1	Box design – IP 65	–	<b>EIB 2391S</b>	
Fanuc serial interface	1	~ 1 V <sub>PP</sub>	1	Box design – IP 65	≤ 16384-fold subdivision	<b>EIB 192F</b>	
				Plug design – IP 40	≤ 16384-fold subdivision	<b>EIB 392F</b>	
			2	Box design – IP 65	≤ 16384-fold subdivision	<b>EIB 1592F</b>	
Mitsubishi high speed interface	1	~ 1 V <sub>PP</sub>	1	Box design – IP 65	≤ 16384-fold subdivision	<b>EIB 192M</b>	
				Plug design – IP 40	≤ 16384-fold subdivision	<b>EIB 392M</b>	
			2	Box design – IP 65	≤ 16384-fold subdivision	<b>EIB 1592M</b>	
Yaskawa serial interface	1	EnDat 2.2 <sup>2)</sup>	1	Plug design – IP 40	–	<b>EIB 3391Y</b>	
PROFIBUS-DP	1	EnDat 2.1; EnDat 2.2	1	Top-hat rail design	–	<b>PROFIBUS Gateway</b>	

<sup>1)</sup> Switchable

<sup>2)</sup> Only LIC 4100 measuring step 5 nm, LIC 2100 measuring step 50 nm and 100 nm

# Evaluation electronics units

## For measuring and testing tasks

**Evaluation electronics** from HEIDENHAIN combine measured value acquisition with intelligent, application-specific further processing. They are used in many metrological applications, ranging from simple measuring stations to complex inspection systems with multiple measuring points.

Evaluation units feature interfaces for various encoder signals. They include units with integrated display—which can be used independently—and units that require a PC for operation.

The overview table lists evaluation electronics for measuring and testing tasks. You can find comprehensive information, including on other evaluation units for 2-D and 3-D measuring tasks, on the Internet under [www.heidenhain.de](http://www.heidenhain.de) or in the product catalog *Evaluation Electronics for Metrology Applications*.

**Digital readouts for manual machine tools** optimally support the operator with cycles for milling, drilling and turning. You can find these digital readouts on the Internet at [www.heidenhain.de](http://www.heidenhain.de) or in the product catalog *Digital Readouts and Linear Encoders for Manually Operated Machine Tools*.



**Unit with integrated display –**  
e.g. ND 2100G GAGE-CHEK



**Modular design –** MSE 1000



**Tabletop design –** EIB 700



**Version for integration –** IK 220

### ND 200

Evaluation unit for

- Measurement equipment
- Adjustment and inspection equipment
- SPC inspection stations

### ND 1100 QUADRA-CHEK

Evaluation electronics for

- Positioning equipment
- Measuring fixtures

### ND 2100G GAGE-CHEK

Evaluation electronics for

- Multipoint inspection apparatuses
- SPC inspection stations

### MSE 1000

Modular evaluation electronics for

- Multipoint inspection apparatuses
- SPC inspection stations

### EIB 700

Evaluation electronics for











- Testing stations
- Multipoint inspection apparatuses
- Mobile data acquisition

### IK 220

Evaluation electronics for installation in computer systems with PCI interface for

- Measuring and testing stations

<sup>1)</sup> Optional for ND 287

Functions	Input		Interpolation or subdivision	Output Interface	Type
	Interface	Qty.			
–	 1 V <sub>PP</sub>  11 μA <sub>PP</sub> EnDat	1	4096-fold	RS-232-C/V-24 USB Ethernet <sup>1)</sup>	<b>ND 280</b>
<ul style="list-style-type: none"> <li>• Metrology and statistical functions (sorting and tolerance checking, measurement series, SPC)</li> <li>• Second encoder<sup>1)</sup> for sum/difference display, temperature compensation</li> </ul>		Up to 2			<b>ND 287</b>
<ul style="list-style-type: none"> <li>• Measurement series with min./max. value storage</li> <li>• Connection for touch probe</li> </ul>	 1 V <sub>PP</sub>  TTL	2	10-fold (at 1 V <sub>PP</sub> )	RS-232-C/V-24 USB	<b>ND 1102</b>
		3			<b>ND 1103</b>
		4			<b>ND 1104</b>
<ul style="list-style-type: none"> <li>• Programming of up to 100 parts</li> <li>• Graphic display of measurement results</li> <li>• Sorting and tolerance checking using tolerance and warning limits</li> <li>• Measurement series with min./max. value storage</li> <li>• Entry of formulas and combinations</li> <li>• Functions for statistical process control (SPC)</li> </ul>	 1 V <sub>PP</sub>  TTL EnDat	4	10-fold (at 1 V <sub>PP</sub> )	RS-232-C/V-24 USB	<b>ND 2104 G</b>
		8			<b>ND 2108 G</b>
<ul style="list-style-type: none"> <li>• Modular design</li> <li>• Configurable as desired</li> <li>• Various interfaces</li> <li>• Fast communication with higher-level computer system</li> <li>• Universal outputs</li> </ul>	 1 V <sub>PP</sub>  TTL EnDat Analog	Up to 250	4096-fold	Ethernet	<b>MSE 1000</b>
<ul style="list-style-type: none"> <li>• Precise position measurement up to 50 kHz updating rate</li> <li>• Programmable measured-value inputs</li> <li>• Internal and external measured-value triggers</li> <li>• Measured-value memory for approx. 250 000 measured values per channel</li> <li>• Connection over standard Ethernet interface to higher-level computer systems</li> </ul>	 1 V <sub>PP</sub>	4	4096-fold	Ethernet	<b>EIB 741</b> <b>EIB 742</b>
<ul style="list-style-type: none"> <li>• Programmable measured-value inputs</li> <li>• Internal and external measured-value triggers</li> <li>• Measured-value memory for 8192 measured values per channel</li> <li>• Optional assemblies for encoder outputs and external inputs/outputs</li> </ul>	 1 V <sub>PP</sub>  11 μA <sub>PP</sub> EnDat SSI	2	4096-fold	PCI bus	<b>IK 220</b>

# HEIDENHAIN

## DR. JOHANNES HEIDENHAIN GmbH

Dr.-Johannes-Heidenhain-Straße 5

83301 Traunreut, Germany

☎ +49 8669 31-0

FAX +49 8669 5061

E-mail: info@heidenhain.de

www.heidenhain.de

Vollständige und weitere Adressen siehe [www.heidenhain.de](http://www.heidenhain.de)  
For complete and further addresses see [www.heidenhain.de](http://www.heidenhain.de)

<b>DE</b>	<b>HEIDENHAIN Vertrieb Deutschland</b> 83301 Traunreut, Deutschland ☎ 08669 31-3132 FAX 08669 32-3132 E-Mail: hd@heidenhain.de	<b>ES</b>	<b>FARRESA ELECTRONICA S.A.</b> 08028 Barcelona, Spain www.farresa.es	<b>PL</b>	<b>APS</b> 02-384 Warszawa, Poland www.heidenhain.pl
	<b>HEIDENHAIN Technisches Büro Nord</b> 12681 Berlin, Deutschland ☎ 030 54705-240	<b>FI</b>	<b>HEIDENHAIN Scandinavia AB</b> 02770 Espoo, Finland www.heidenhain.fi	<b>PT</b>	<b>FARRESA ELECTRÓNICA, LDA.</b> 4470 - 177 Maia, Portugal www.farresa.pt
	<b>HEIDENHAIN Technisches Büro Mitte</b> 07751 Jena, Deutschland ☎ 03641 4728-250	<b>FR</b>	<b>HEIDENHAIN FRANCE sarl</b> 92310 Sèvres, France www.heidenhain.fr	<b>RO</b>	<b>HEIDENHAIN Reprezentantă Romania</b> Braşov, 500407, Romania www.heidenhain.ro
	<b>HEIDENHAIN Technisches Büro West</b> 44379 Dortmund, Deutschland ☎ 0231 618083-0	<b>GB</b>	<b>HEIDENHAIN (G.B.) Limited</b> Burgess Hill RH15 9RD, United Kingdom www.heidenhain.co.uk	<b>RS</b>	Serbia → <b>BG</b>
	<b>HEIDENHAIN Technisches Büro Südwest</b> 70771 Leinfelden-Echterdingen, Deutschland ☎ 0711 993395-0	<b>GR</b>	<b>MB Milionis Vassilis</b> 17341 Athens, Greece www.heidenhain.gr	<b>RU</b>	<b>OOO HEIDENHAIN</b> 115172 Moscow, Russia www.heidenhain.ru
	<b>HEIDENHAIN Technisches Büro Südost</b> 83301 Traunreut, Deutschland ☎ 08669 31-1345	<b>HK</b>	<b>HEIDENHAIN LTD</b> Kowloon, Hong Kong E-mail: sales@heidenhain.com.hk	<b>SE</b>	<b>HEIDENHAIN Scandinavia AB</b> 12739 Skärholmen, Sweden www.heidenhain.se
		<b>HR</b>	Croatia → <b>SL</b>	<b>SG</b>	<b>HEIDENHAIN PACIFIC PTE LTD.</b> Singapore 408593 www.heidenhain.com.sg
<b>AR</b>	<b>NAKASE SRL.</b> B1653AOX Villa Ballester, Argentina www.heidenhain.com.ar	<b>HU</b>	<b>HEIDENHAIN Kereskedelmi Képviselet</b> 1239 Budapest, Hungary www.heidenhain.hu	<b>SK</b>	<b>KOPRETINA TN s.r.o.</b> 91101 Trenčín, Slovakia www.kopretina.sk
<b>AT</b>	<b>HEIDENHAIN Techn. Büro Österreich</b> 83301 Traunreut, Germany www.heidenhain.de	<b>ID</b>	<b>PT Servitama Era Toolsindo</b> Jakarta 13930, Indonesia E-mail: ptset@group.gts.co.id	<b>SL</b>	<b>NAVO d.o.o.</b> 2000 Maribor, Slovenia www.heidenhain.si
<b>AU</b>	<b>FCR Motion Technology Pty. Ltd</b> Laverton North 3026, Australia E-mail: vicsales@fcrmotion.com	<b>IL</b>	<b>NEUMO VARGUS MARKETING LTD.</b> Tel Aviv 61570, Israel E-mail: neumo@neumo-vargus.co.il	<b>TH</b>	<b>HEIDENHAIN (THAILAND) LTD</b> Bangkok 10250, Thailand www.heidenhain.co.th
<b>BE</b>	<b>HEIDENHAIN NV/SA</b> 1760 Roosdaal, Belgium www.heidenhain.be	<b>IN</b>	<b>HEIDENHAIN Optics &amp; Electronics India Private Limited</b> Chetpet, Chennai 600 031, India www.heidenhain.in	<b>TR</b>	<b>T&amp;M Mühendislik San. ve Tic. LTD. ŞTİ.</b> 34728 Ümraniye-Istanbul, Turkey www.heidenhain.com.tr
<b>BG</b>	<b>ESD Bulgaria Ltd.</b> Sofia 1172, Bulgaria www.esd.bg	<b>IT</b>	<b>HEIDENHAIN ITALIANA S.r.l.</b> 20128 Milano, Italy www.heidenhain.it	<b>TW</b>	<b>HEIDENHAIN Co., Ltd.</b> Taichung 40768, Taiwan R.O.C. www.heidenhain.com.tw
<b>BR</b>	<b>DIADUR Indústria e Comércio Ltda.</b> 04763-070 – São Paulo – SP, Brazil www.heidenhain.com.br	<b>JP</b>	<b>HEIDENHAIN K.K.</b> Tokyo 102-0083, Japan www.heidenhain.co.jp	<b>UA</b>	<b>Gertner Service GmbH Büro Kiev</b> 01133 Kiev, Ukraine www.heidenhain.ua
<b>BY</b>	<b>GERTNER Service GmbH</b> 220026 Minsk, Belarus www.heidenhain.by	<b>KR</b>	<b>HEIDENHAIN Korea LTD.</b> Gasan-Dong, Seoul, Korea 153-782 www.heidenhain.co.kr	<b>US</b>	<b>HEIDENHAIN CORPORATION</b> Schaumburg, IL 60173-5337, USA www.heidenhain.com
<b>CA</b>	<b>HEIDENHAIN CORPORATION</b> Mississauga, Ontario L5T2N2, Canada www.heidenhain.com	<b>MX</b>	<b>HEIDENHAIN CORPORATION MEXICO</b> 20235 Aguascalientes, Ags., Mexico E-mail: info@heidenhain.com	<b>VE</b>	<b>Maquinaria Diekmann S.A.</b> Caracas, 1040-A, Venezuela E-mail: purchase@diekmann.com.ve
<b>CH</b>	<b>HEIDENHAIN (SCHWEIZ) AG</b> 8603 Schwerzenbach, Switzerland www.heidenhain.ch	<b>MY</b>	<b>ISOSERVE SDN. BHD.</b> 43200 Balakong, Selangor E-mail: isoserve@po.jaring.my	<b>VN</b>	<b>AMS Co. Ltd</b> HCM City, Vietnam E-mail: davidgoh@amsvn.com
<b>CN</b>	<b>DR. JOHANNES HEIDENHAIN (CHINA) Co., Ltd.</b> Beijing 101312, China www.heidenhain.com.cn	<b>NL</b>	<b>HEIDENHAIN NEDERLAND B.V.</b> 6716 BM Ede, Netherlands www.heidenhain.nl	<b>ZA</b>	<b>MAFEMA SALES SERVICES C.C.</b> Midrand 1685, South Africa www.heidenhain.co.za
<b>CZ</b>	<b>HEIDENHAIN s.r.o.</b> 102 00 Praha 10, Czech Republic www.heidenhain.cz	<b>NO</b>	<b>HEIDENHAIN Scandinavia AB</b> 7300 Orkanger, Norway www.heidenhain.no		
<b>DK</b>	<b>TPTEKNIK A/S</b> 2670 Greve, Denmark www.tp-gruppen.dk	<b>PH</b>	<b>Machinebanks Corporation</b> Quezon City, Philippines 1113 E-mail: info@machinebanks.com		

