

HEIDENHAIN-CERTO

Length Gauges with $\pm 0.1 \mu\text{m}/\pm 0.05 \mu\text{m}^*/\pm 0.03 \mu\text{m}^*$ Accuracy

- For very high accuracy
- For inspection of measuring equipment and gauge blocks

HEIDENHAIN-CERTO length gauges feature a large measuring range, provide high linear accuracy and offer resolution in the nanometer range. They are used predominantly for production quality control of high-precision parts and for the monitoring and calibration of reference standards. Length gauges reduce the number of working standards required to calibrate gauge blocks.

Accuracy

The total error of HEIDENHAIN-CERTO length gauges lies within $\pm 0.1 \mu\text{m}$. After linear length error compensation in the evaluation electronics of the ND 28x, for example, HEIDENHAIN guarantees accuracy of $\pm 0.03 \mu\text{m}$ for the CT 2500 and $\pm 0.05 \mu\text{m}$ for the CT 6000. These accuracy grades apply over the entire measuring range at ambient temperatures between 19 and 21 °C and with a temperature variation of $\pm 0.1 \text{ K}$ during measurements using the CS 200 gauge stand for HEIDENHAIN-CERTO.

Plunger actuation

The plungers of the **CT 2501** and **CT 6001** are extended and retracted by an integral motor. It can be actuated by the associated switch box, which can also be controlled by external signal.

CT 2502 and **CT 6002** have no plunger drive. The freely movable plunger is connected by a separate coupling with the moving machine element.

Mounting

The CT 2500 length gauge is fastened by its 16 mm diameter clamping shank. The CT 6000 is fastened with two screws on a plane surface. The CS 200 gauge stand (see *Accessories*) was conceived specially for HEIDENHAIN-CERTO length gauges. It fulfills the requirements of high precision measurement with respect to thermal behavior, stability, orthogonality and flatness of the measuring plate surface. A special holder is available as an accessory for mounting the CT 2500.

Output signals

The HEIDENHAIN-CERTO length gauges provide $\sim 11 \mu\text{A}_{\text{app}}$ current signals for HEIDENHAIN subsequent electronics.

* After linear length-error compensation in the evaluation electronics

Dimensions in mm



Tolerancing ISO 8015

ISO 2768 - m H

< 6 mm: $\pm 0.2 \text{ mm}$

⊙ = Reference mark position

CT 2500

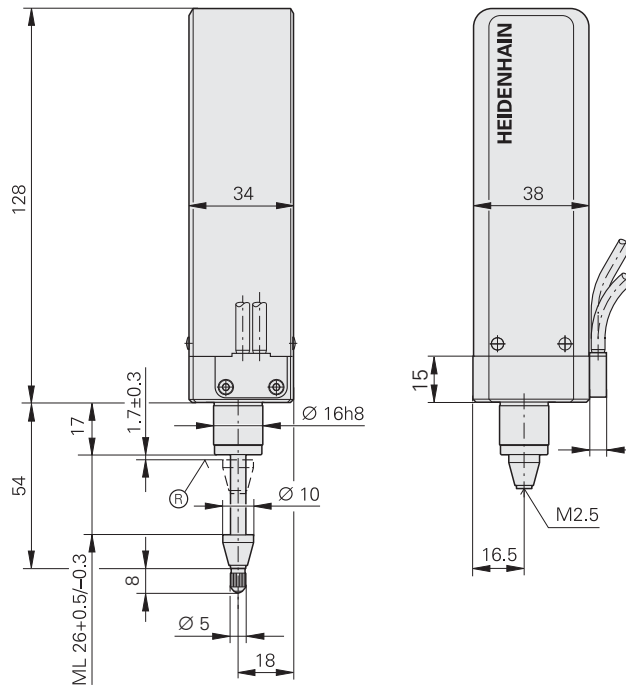

CT 6000

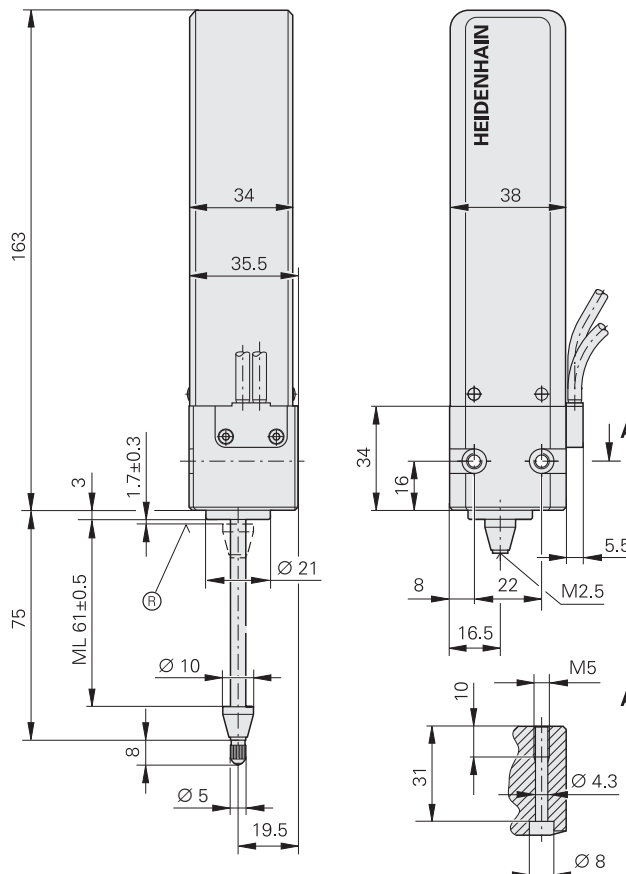

Specifications	CT 2501 CT 6001	CT 2502 CT 6002
Plunger actuation	By motor	Plunger connected via separate coupling with moving machine part
Measuring standard	DIADUR phase grating on Zerodur® glass ceramic Grating period 4 µm	
System accuracy at 19 to 21 °C <i>CT 2500</i> <i>CT 6000</i>	± 0.1 µm without compensation; ± 0.03 µm after linear length error compensation ± 0.05 µm after linear length error compensation	
Recommd. meas. step	0.01 µm/0.005 µm (5 nm) with ND 28x	
Reference mark	Approx. 1.7 mm below upper stop	
Measuring range <i>CT 2500</i> <i>CT 6000</i>	25 mm 60 mm	
Gauging force Vertically downward Vertically upward Horizontal	1 N/1.25 N/1.75 N – /– /0.75 N – /0.75 N/1.25 N	–
Required moving force	–	0.1 N to 0.6 N (depending on operating attitude)
Radial force	≤ 0.5 N (mechanically permissible)	
Operating attitude	Any required (for preferred operating attitude see page 13)	
Vibration 55 to 2000 Hz Shock 11 ms	≤ 100 m/s ² (EN 60068-2-6) ≤ 1000 m/s ² (EN 60068-2-27)	
Protection EN 60529	IP 50	
Operating temperature	10 to 40 °C; ref. temperature 20 °C	
Fastening <i>CT 2500</i> <i>CT 6000</i>	Clamping shank Ø16h8 Plane surface	
Weight <i>CT 2500</i> without cable <i>CT 6000</i>	520 g 700 g	480 g 640 g
Incremental signals	~ 11 µA _{PP} ; signal period 2 µm	
Measuring velocity	≤ 24 m/min (depending on the subsequent electronics) ≤ 12 m/min with the ND 28x display unit	
Electrical connection*	<ul style="list-style-type: none"> • Cable, 1.5 m, with 15-pin D-sub connector • Cable, 1.5 m, with 9-pin M23 connector Interface electronics are integrated in connector.	
Cable length	≤ 30 m with HEIDENHAIN cable	
Power supply	5 V ± 5 %/< 180 mA	5 V ± 5 %/< 120 mA

Required accessories*	For CT 2501	For CT 6001
Switch box	SG 25M ID 317436-01	SG 60M ID 317436-02

* Please indicate when ordering

CT 2500



CT 6000



Representante oficial de:



HEIDENHAIN

[Argentina – Bolivia – Chile – Colombia - Costa Rica – Ecuador - El Salvador –
Guatemala – Honduras – Nicaragua – Panamá – Paraguay – Perú -
República Dominicana – Uruguay – Venezuela.]



Calle 49 N° 5764 - Villa Ballester (B1653AOX) - Prov. de Buenos Aires - ARGENTINA
Tel: (+54 11) 4768-4242 / Fax: (+54 11) 4849-1212
Mail: ventas@nakase.com.ar / Web: www.nakase.com.ar

