



HEIDENHAIN



Product Information

EIB 192

External Interface Box

May 2007

EIB 192

External Interface Box

- Interpolation and digitizing electronics
- Integrated 16384-fold interpolation
- Input: Incremental encoders from HEIDENHAIN
- Output: Absolute position values to EnDat 2.2, Fanuc Serial Interface or Mitsubishi High Speed Serial Interface

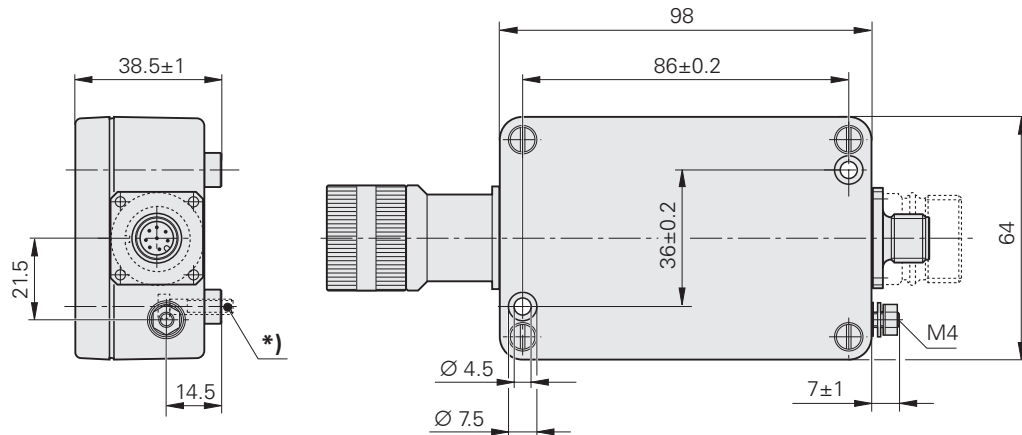

Dimensions in mm

*) 2 mounting screws (M4 x 16 DIN 912/ISO 4762)



Tolerancing ISO 8015
ISO 2768 - m H
< 6 mm: ±0.2 mm





Specifications	EIB 192	EIB 192F	EIB 192M
Input			
Incremental signals	~ 1 V _{PP}		
Input frequency	≤ 400 kHz		
Electrical connection	M23 connector, 12-pin		
Cable length	≤ 6 m		
Output			
Absolute position values	EnDat 2.2	Fanuc Serial Interface	Mitsubishi High Speed Serial Interface
Order designation	EnDat 22	Fanuc 02	Mit 02-4 / Mit 02-2*
Electrical connection	M12, 8-pin	M23, 17-pin	M23, 17-pin
Cable length	≤ 100 m ¹⁾	≤ 20 m ²⁾	≤ 20 m ²⁾
Interpolation	≤ 16384-fold (depending on the encoder)		
Power supply	5 V ± 5% measured at EIB		
Current consumption	≤ 160 mA (without load, without encoder)		
Operating temperature	0 °C to 70 °C		
Storage temperature	-30 °C to 70 °C		
Vibration 55 to 2000 Hz Shock 11 ms	100 m/s ² (IEC 60068-2-6) 300 m/s ² (IEC 60068-2-27)		
Degree of protection	IP 65		
Weight	Approx. 0.3 kg		

¹⁾ with HEIDENHAIN cable; supply voltage of 5 V ± 5% at the EIB must be maintained





²⁾ with HEIDENHAIN cable; I_{Encoder} ≤ 150 mA; greater cable lengths upon request; * Mitsu01 upon request





Electrical Connection







Pin layout of connecting element to the EIB input

12-pin M23 coupling												
	Power supply				Incremental signals						Limit pos. sign.	
	12	2	10	11	5	6	8	1	3	4	7	9
	U_P	Sensor U_P	0V	Sensor 0V	A+	A-	B+	B-	R+	R-	H/L1 ¹⁾	L/L2 ¹⁾
	Brown/ Green	Blue	White/ Green	White	Brown	Green	Gray	Pink	Red	Black	Violet	Yellow

Pin layout of connecting element to the EIB output

EIB 192 8-pin M12 connector								
	Power supply				Absolute position values			
	2	8	1	5	3	4	7	6
	$U_P^{2)}$	U_P	0V ²⁾	0V	DATA	DATA	CLOCK	CLOCK
	Blue	Brown/Green	White	White/Green	Gray	Pink	Violet	Yellow

EIB 192F 17-pin M23 connector					20-pin Fanuc connector				
	Power supply				Absolute position values				
	7	1	10	4	-	14	17	8	9
	9	18/20	12	14	16	1	2	5	6
	U_P	Sensor U_P	0V	Sensor 0V	Shield	Serial Data	Serial Data	Request	Request
	Brown/Green	Blue	White/Green	White	-	Gray	Pink	Violet	Yellow

EIB 192M 17-pin M23 connector					10 or 20-pin Mitsubishi connector			
	Power supply				Absolute position values			
	7	1	10	4	14	17	8	9
	20	19	1	11	6	16	7	17
	1	-	2	-	7	8	3	4
	U_P	Sensor U_P	0V	Sensor 0V	Serial Data	Serial Data	Request Frame ³⁾	Request Frame ³⁾
	Brown/Green	Blue	White/Green	White	Gray	Pink	Violet	Yellow

Shield on housing; U_P = power supply voltage







Sensor: The sensor line is connected internally with the corresponding power line
Vacant pins or wires must not be used!

¹⁾ Only for LIF 481/LIDA 48x; color assignment applies only to connecting cable

²⁾ For parallel supply lines

³⁾ Do not use on Mit 02-2

Cables

	EIB 192	EIB 192F	EIB 192M
Connecting cable complete	ID 368330-xx 	ID 349314-xx 	
Adapter cable complete	With D-sub connector (female) ID 524599-xx 	With Fanuc connector ID 534855-xx 	With Mitsubishi connector 10-pin ID 573661-xx* 20-pin ID 367958-xx* 
Connecting cable with one connector	ID 634265-xx 	-	

* for Mit 02-2 upon request

Configuration of the EIB 192

In order for the EIB 192 to function correctly together with the encoder, certain encoder parameters must be stored in the EIB 192 (such as the number of signal periods, nominal increment of the reference marks, encoder ID, etc.). Only HEIDENHAIN can program this information. This information is also printed on the ID label. It can also be read out via the EnDat interface.

Information on the ID label

The **data interface** designates the type of interface for transmission of the position values at the output of the EIB.

Line count or signal period

For rotatory encoders the number of signal periods per revolution is indicated. For linear encoders the signal period is shown in μm .

The **encoder ID** indicates the type of encoder that can be connected, e.g. EnDat 22:

- 00 Incremental linear encoder without distance-coded reference marks
 - 10 Incremental linear encoder with distance-coded reference marks
 - 80 Incremental rotary or angle encoder without distance-coded reference marks
 - 90 Incremental rotary or angle encoder with distance-coded reference marks
- For the EnDat interface this value is stored in word 14 of the EnDat 2.1 parameters.

The **nominal increment N of the reference marks** is indicated in signal periods if the connected encoder has distance-coded reference marks (EnDat 2.2 encoder ID = 10 or 90).

Example:

Connection of an ERM 280 (line count: 1024) with an EIB 192 to the EnDat 2.2 interface

Information on the ID label:
Data interface: EnDat22
Encoder ID: 80
Line count or signal period: 1024
Nominal increment of the ref. marks: –

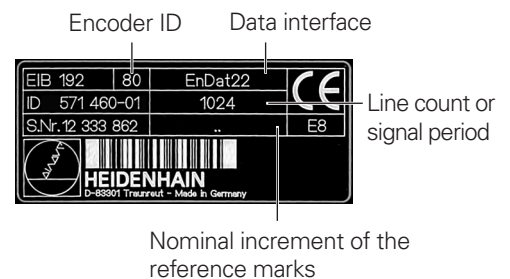

HEIDENHAIN

DR. JOHANNES HEIDENHAIN GmbH

Dr.-Johannes-Heidenhain-Straße 5

83301 Traunreut, Germany

☎ +49 (8669) 31-0

FAX +49 (8669) 5061

E-Mail: info@heidenhain.de

www.heidenhain.de

For more information

- *Interface Electronics Product Overview*

Representante oficial de:



HEIDENHAIN

[Argentina – Bolivia – Chile – Colombia - Costa Rica – Ecuador - El Salvador –
Guatemala – Honduras – Nicaragua – Panamá – Paraguay – Perú -
República Dominicana – Uruguay – Venezuela.]



Calle 49 N° 5764 - Villa Ballester (B1653AOX) - Prov. de Buenos Aires - ARGENTINA
Tel: (+54 11) 4768-4242 / Fax: (+54 11) 4849-1212
Mail: ventas@nakase.com.ar / Web: www.nakase.com.ar

