



HEIDENHAIN



Length Gauges

March 2012

Representante oficial de:



HEIDENHAIN

[Argentina – Bolivia – Chile – Colombia - Costa Rica – Ecuador - El Salvador –
Guatemala – Honduras – Nicaragua – Panamá – Paraguay – Perú -
República Dominicana – Uruguay – Venezuela.]



Calle 49 N° 5764 - Villa Ballester (B1653AOX) - Prov. de Buenos Aires - ARGENTINA
Tel: (+54 11) 4768-4242 / Fax: (+54 11) 4849-1212
Mail: ventas@nakase.com.ar / Web: www.nakase.com.ar



Length gauges from HEIDENHAIN offer high accuracy over long measuring ranges. These sturdily made gauges are available in application-oriented versions.

They have a wide range of applications in production metrology, in multipoint inspection stations, measuring equipment monitoring, and as position measuring devices.



This catalog supersedes all previous editions, which thereby become invalid. The basis for ordering from HEIDENHAIN is always the catalog edition valid when the contract is made.

Standards (ISO, EN, etc.) apply only where explicitly stated in the catalog.



Length Gauges – Applications and Products			
Range of Applications, Application Examples			4
Length Gauges from HEIDENHAIN			6
Length Gauge Overview			8
Technical Features and Mounting Information			
Principle of Function			10
Mechanical Design			11
Measuring Accuracy			12
Gauging Force and Plunger Actuation			14
Mounting			16
Specifications	<i>Accuracy</i>	<i>Measuring range</i>	
ACANTO Absolute Length Gauges	$\pm 2 \mu\text{m}$	12 mm	18
HEIDENHAIN-CERTO Incremental Length Gauges	$\pm 0.1 \mu\text{m}$; $\pm 0.03 \mu\text{m}^*$ $\pm 0.1 \mu\text{m}$; $\pm 0.05 \mu\text{m}^*$	25 mm 60 mm	20
Incremental Length Gauges	$\pm 0.2 \mu\text{m}$	12 mm 25 mm	22
HEIDENHAIN-METRO Incremental Length Gauges	$\pm 0.5 \mu\text{m}$ $\pm 1 \mu\text{m}$	60 mm 100 mm	24
HEIDENHAIN-SPECTO Incremental Length Gauges	$\pm 1 \mu\text{m}$	12 mm 30 mm	26
Length Gauge Accessories			
Measuring Contacts, Switch Boxes, Coupling			28
Gauge Stands, Ceramic Suction Plate, Diaphragm Compressor	For HEIDENHAIN-CERTO		30
Cable-Type Lifter, Gauge Stands	for HEIDENHAIN-METRO and HEIDENHAIN-SPECTO		32
Evaluation and Display Units			
Digital Readouts			34
Evaluation Electronics			35
Electrical Connection			
Interfaces	Incremental Signals $\sim 11 \mu\text{A}_{\text{PP}}$		37
	Incremental Signals $\sim 1 \text{V}_{\text{PP}}$		38
	Incremental Signals \square TTL		40
	EnDat Absolute Position Values		42
Cables and Connecting Elements			44
General Electrical Information			48

* After linear length-error compensation in the evaluation electronics

Range of Applications In Quality Assurance

Metrology and production control

Incremental length gauges from HEIDENHAIN play a role in incoming goods inspection, fast dimension checking during production, statistical process control in production or quality assurance, or in any application where fast, reliable and accurate length measurement is required. Their large measuring lengths are a particular advantage: whether the part measures 5 mm or 95 mm, it is measured immediately with one and the same length gauge.

Whatever the application, HEIDENHAIN has the appropriate length gauge for the required accuracy. The **HEIDENHAIN-CERTO** length gauges offer a very high accuracy of $\pm 0.1 \mu\text{m}/\pm 0.05 \mu\text{m}^*/\pm 0.03 \mu\text{m}^*$ for extremely precise measurement. Length gauges from the **HEIDENHAIN-METRO** program have accuracy grades as fine as $\pm 0.2 \mu\text{m}$, while the **HEIDENHAIN-SPECTO** length gauges, with $\pm 1 \mu\text{m}$ accuracy, offer particularly compact dimensions.

* After linear length-error compensation in the evaluation electronics



Gauge block calibration and measuring device inspection

The usual inspection of measuring equipment called for by standards, and the inspection of gauge blocks in particular, necessitate a large number of reference standard blocks if the comparative measurement is performed using inductive length gauges. The problem is the small measuring range of inductive gauges: they can measure length differences of only up to $10 \mu\text{m}$. Incremental length gauges, which offer large measuring ranges together with high accuracy, greatly simplify the calibration of measuring devices required to ensure traceability.

The length gauges of the **HEIDENHAIN-CERTO** program with measuring ranges of 25 mm with $\pm 0.1 \mu\text{m}/\pm 0.03 \mu\text{m}^*$ accuracy and 60 mm with $\pm 0.1 \mu\text{m}/\pm 0.05 \mu\text{m}^*$ accuracy are especially well suited for this task. It permits a significant reduction in the required number of reference standard blocks, and recalibrating becomes much simpler.

Thickness gauging of silicon wafers



Inspection of styli



Calibration of gauge blocks

In Production

Multipoint inspection apparatuses

Multipoint inspection devices require durable length gauges with small dimensions. They should also have relatively large measuring ranges of several millimeters with consistent linear accuracy in order to simplify the construction of inspection devices—for example by enabling the construction of one device for several masters. A large measuring length also provides benefits in master production, because simpler masters can be used.

Thanks to their small dimensions, the **ACANTO** absolute length gauge, like the **HEIDENHAIN-SPECTO** incremental length gauge, are specially designed for multi-point measuring stations. The feature accuracy grades up to $\pm 1 \mu\text{m}$ over measuring ranges up to 30 mm. Higher accuracy requirements up to $\pm 0.2 \mu\text{m}$ can be met with similarly compact **HEIDENHAIN-METRO** length gauges.

Unlike inductive gauges, HEIDENHAIN-SPECTO length gauges provide stable measurement over long periods—eliminating recalibration.



Position measurement

Incremental length gauges from HEIDENHAIN are also ideal for position measurement on precision linear slides or X-Y tables. Working with measuring microscopes, for example, becomes much easier thanks to the digital readout and the flexible datum setting.

Here, length gauges from the **HEIDENHAIN-METRO** and **HEIDENHAIN-SPECTO** program come into use with large measuring ranges of 30 mm, 60 mm or 100 mm at consistently high accuracy grades of $\pm 0.5 \mu\text{m}$ or $\pm 1 \mu\text{m}$.

In this application as linear measuring device, the length gauge's fast installation in accordance with the Abbe measuring principle by its clamping shank or planar mounting surface is of special benefit.

Testing station for flatness inspection

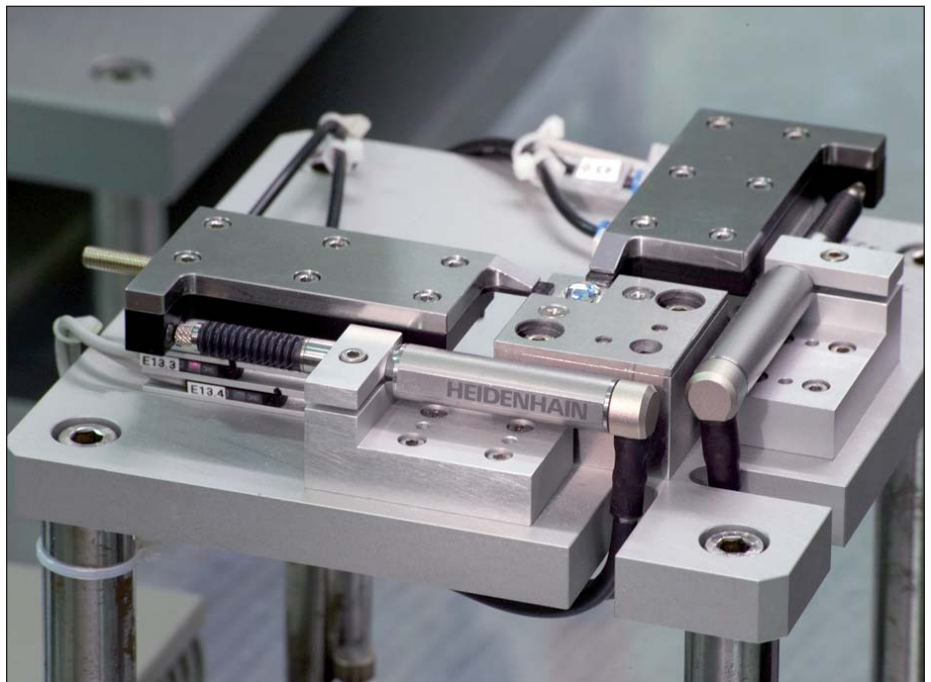

Position measurement on an X-Y table for lens mounting

Tolerance gauging of semifinished products

Length Gauges from HEIDENHAIN

A number of arguments speak for HEIDENHAIN length gauges. These include not only their technical features, but also their high quality standard and the worldwide presence of HEIDENHAIN.

Large measuring ranges

HEIDENHAIN length gauges are available with measuring lengths of 12 mm, 25 mm, 30 mm, 60 mm or 100 mm. so that you can measure very different parts in one measuring setup and avoid frequently changing setups with expensive gauge blocks or masters.

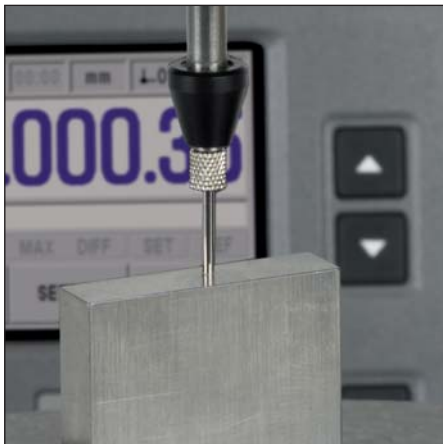

High accuracy

The high accuracy specified for HEIDENHAIN length gauges applies over the entire measuring length. Whether the part measures 10 or 100 mm, its actual dimension is always measured with the same high quality. The high repeatability of HEIDENHAIN length gauges comes into play during comparative measurements, for example in series production.



Robust design

HEIDENHAIN length gauges are built for an industrial environment. They feature consistently high accuracy over a long period of time as well as high thermal stability. They can therefore be used in production equipment and machines.

Wide range of applications

HEIDENHAIN length gauges are suited for many applications. Automatic inspection equipment, manual measuring stations or positioning equipment—wherever lengths, spacing, thickness, height or linear motion are to be measured, HEIDENHAIN length gauges function quickly, reliably and accurately.



Absolute position measurement

The ACANTO length gauges operate with absolute measurement over a range of 12 mm and with high repeatability. It's particular advantage is that the measured value is available immediately after switch-on.

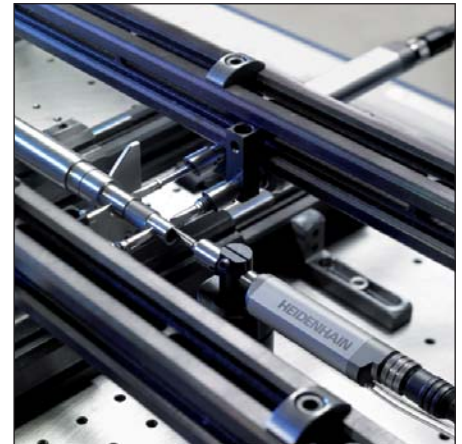

Know-how

The high quality of HEIDENHAIN length gauges is no coincidence. HEIDENHAIN has been manufacturing high-accuracy scales for over 70 years, and for many years it has developed measuring and testing devices for length and angle measurement for national standards laboratories. This know-how makes HEIDENHAIN an extraordinarily qualified partner for metrology questions.

Worldwide presence

HEIDENHAIN is represented in all important industrial countries—in most of them with wholly owned subsidiaries. Sales engineers and service technicians support the user on-site with technical information and servicing in the local language.



Length Gauge Overview



MT 101



MT 60



CT 6000



CT 2500

Accuracy	Measuring range <i>Plunger actuation</i>
Absolute position measurement	
$\pm 2 \mu\text{m}$	ACANTO
	<i>By measured object</i> <i>Pneumatic</i>
Incremental linear measurement	
$\pm 0.1 \mu\text{m}$ $\pm 0.05 \mu\text{m}^{*)}$ $\pm 0.03 \mu\text{m}^{*)}$	HEIDENHAIN-CERTO
	<i>By motor</i> <i>By external coupling</i>
$\pm 0.2 \mu\text{m}$	HEIDENHAIN-METRO
	<i>By cable lifter or measured object</i> <i>Pneumatic</i>
$\pm 0.5 \mu\text{m}$ $\pm 1 \mu\text{m}$	HEIDENHAIN-METRO
	<i>By motor</i> <i>By external coupling</i>
$\pm 1 \mu\text{m}$	HEIDENHAIN-SPECTO
	<i>By measured object</i> <i>Pneumatic</i>

^{*)} After linear length-error compensation in the evaluation electronics

12 mm	25 mm/ 30 mm	60 mm	100 mm	Page
				18
AT 1218 EnDat AT 1217 EnDat				
				20
	CT 2501 \sim 11 μ A _{PP} CT 2502 \sim 11 μ A _{PP}	CT 6001 \sim 11 μ A _{PP} CT 6002 \sim 11 μ A _{PP}		
				22
MT 1271 \square TTL MT 1281 \sim 1 V _{PP} MT 1287 \sim 1 V _{PP}	MT 2571 \square TTL MT 2581 \sim 1 V _{PP} MT 2587 \sim 1 V _{PP}			
				24
		MT 60M \sim 11 μ A _{PP} MT 60K \sim 11 μ A _{PP}	MT 101M \sim 11 μ A _{PP} MT 101K \sim 11 μ A _{PP}	
				26
ST 1278 \square TTL ST 1288 \sim 1 V _{PP} ST 1277 \square TTL ST 1287 \sim 1 V _{PP}	ST 3078 \square TTL ST 3088 \sim 1 V _{PP} ST 3077 \square TTL ST 3087 \sim 1 V _{PP}			



MT 2500



MT 1200



ST 3000



ST 1200



AT 1200

Principle of Function

HEIDENHAIN length gauges are characterized by long measuring ranges and consistently high accuracy. The basis for both is the photoelectrical scanning principle.

HEIDENHAIN linear encoders use material measuring standards consisting of absolute or incremental graduations on substrates of glass or glass ceramic. These measuring standards permit large measuring ranges, are insensitive to vibration and shock, and have a defined thermal behavior. Changes in atmospheric pressure or relative humidity have no influence on the accuracy of the measuring standard—which is the prerequisite for the **high long-term stability** of HEIDENHAIN length gauges.

The masters for these graduations are fabricated on dividing engines developed and built by HEIDENHAIN. High thermal stability during the manufacturing process ensures that the graduations have **high accuracy** over the measuring length. The master graduation is applied to the carrier using the DIADUR copying process developed by HEIDENHAIN, which produces very thin but durable graduation structures of chromium.

The graduation is **photoelectrically scanned** without mechanical contact and therefore without wear. Light passes through the structured scanning reticle and over the scale onto photovoltaic cells. The photovoltaic cells produce sinusoidal output signals with a small signal period. Interpolation in the subsequent electronics makes very small measuring steps into the nanometer range possible. The scanning principle, together with the extremely fine graduation lines and their high edge definition ensure the quality of the output signals as well as the **small position error within one signal period**. This applies particularly to HEIDENHAIN length gauges, which use a DIADUR phase grating as measuring standard. The interferential scanning method produces sinusoidal incremental signals with a period of only 2 μm .

Incremental Measuring Method

With the incremental measuring method, the graduation consists of a periodic grating structure. The position information is obtained **by counting** the individual increments (measuring steps) from some point of origin. Since an absolute reference is required to ascertain positions, the measuring standard is provided with an additional track that bears a **reference mark**. The absolute position on the scale, established by the reference mark, is gated with exactly one signal period. The reference mark must therefore be scanned to establish an absolute reference or to find the last selected datum.

Absolute measuring method

With the absolute measuring method, the position value is available from the encoder immediately upon switch-on and can be called at any time by the subsequent electronics. There is no need to move the axes to find the reference position. The absolute position information is read **from the graduated disk**, which is formed from a serial absolute code structure. A separate incremental track is interpolated for the position value and at the same time—depending on the interface version—is used to generate an optional incremental signal.

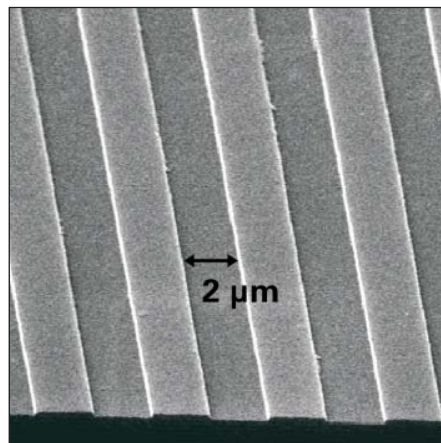
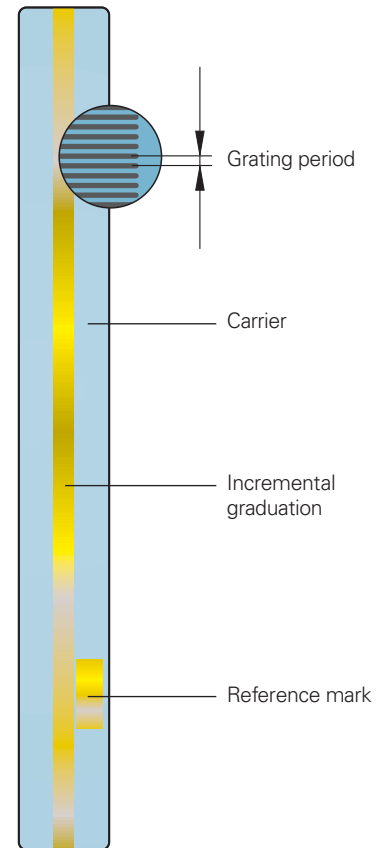

DIADUR phase grating with approx. 0.25 μm grating height

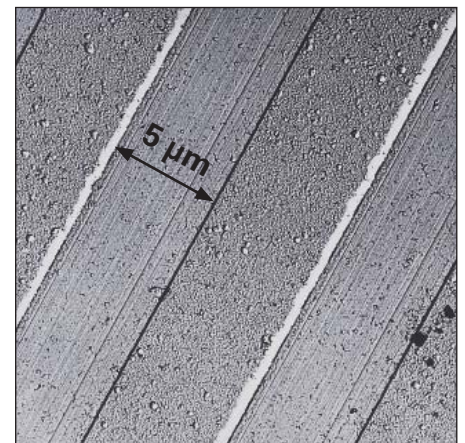

DIADUR graduation

Mechanical Design

HEIDENHAIN length gauges function according to the **Abbe measuring principle**, i.e. the measuring standard and the plunger are exactly aligned. All components comprising the **measuring loop**, such as the measuring standard, plunger, holder and scanning head are designed in terms of their mechanical and thermal stability for the highest possible accuracy of the length gauge.

HEIDENHAIN length gauges have a defined **thermal behavior**. Since temperature variations during measurement can result in changes in the measuring loop, HEIDENHAIN uses special materials with low coefficients of expansion α_{therm} for the components of the measuring loop, for example in the CERTO length gauges. The scale is manufactured of Zerodur ($\alpha_{\text{therm}} \approx 0 \text{ K}^{-1}$), and the plunger and holder are of Invar ($\alpha_{\text{therm}} \approx 1 \cdot 10^{-6} \text{ K}^{-1}$). This makes it possible to guarantee its high measuring accuracy over a relatively large temperature range.

Length gauges from HEIDENHAIN feature a **sturdy design**. Even high vibration and shock loads have no negative influence on the accuracy.

The **ball-bush guided plunger** tolerates high radial forces and moves with very low friction. It has an M2.5 thread to hold measuring contacts.

Expendable parts

HEIDENHAIN length gauges contain components that are subject to wear, depending on the application and manipulation. These include in particular the following parts:

- LED light source
- Guideway (tested for at least 5 million strokes*)
- Cable link for CT, MT 60 and MT 101 (tested for at least 1 million strokes*)
- Scraper rings
- Rubber bellows for AT and ST 1200

* With CT, MT 60M and MT 101 M only with actuation by switch box

DIADUR is a registered trademark of DR. JOHANNES HEIDENHAIN GmbH, Traunreut, Germany.
Zerodur® is a registered trademark of Schott-Glaswerke, Mainz, Germany.

Layout of ST 1200

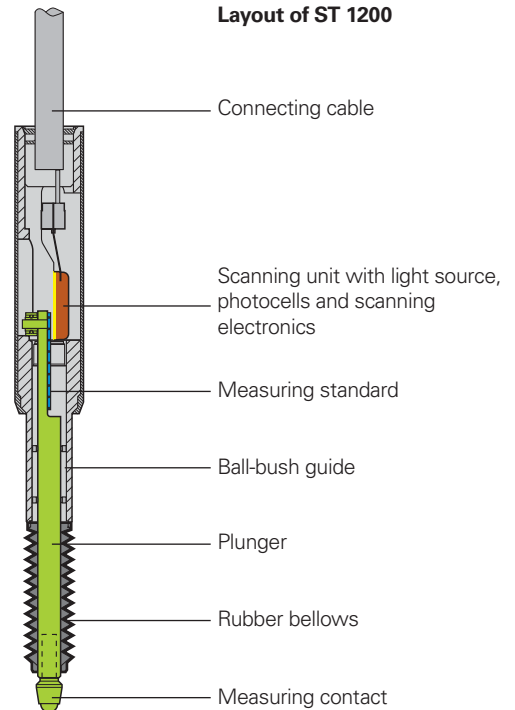

Layout of CT 6000 MT 60

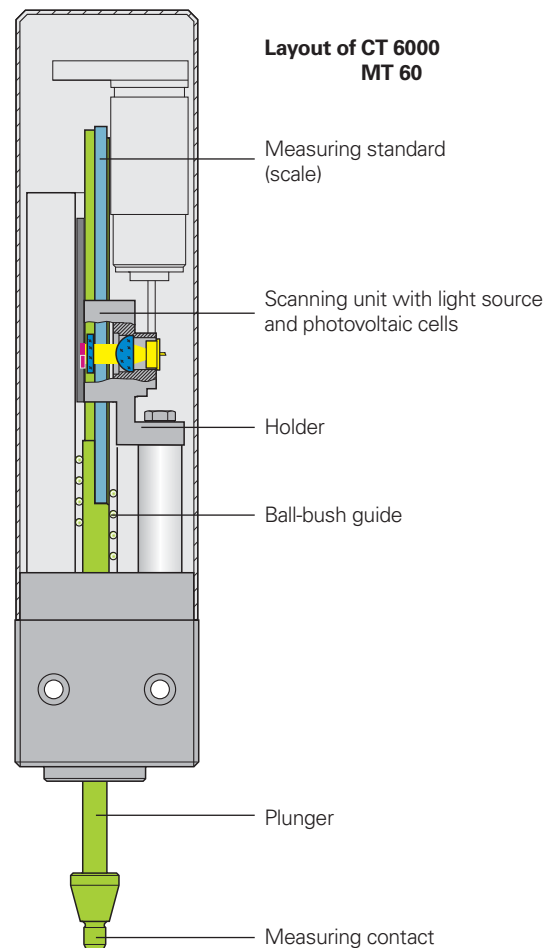

Measuring Accuracy

The accuracy of position measurement with length gauges is mainly determined by the following factors:

- the quality of the graduation,
- the quality of the scanning process,
- the quality of the signal processing electronics,
- the error from the scale guideway relative to the scanning unit.

A distinction is made between position error over relatively large paths of traverse—for example the entire measuring range—and that within one signal period.

Position error over the measuring range

Length gauge accuracy is specified as system accuracy, which is defined as follows:

*The extreme values of the **total error***

F—with reference to their mean value—lie over the entire measuring length within the system accuracy $\pm a$. They are measured during the final inspection and documented in the calibration chart.

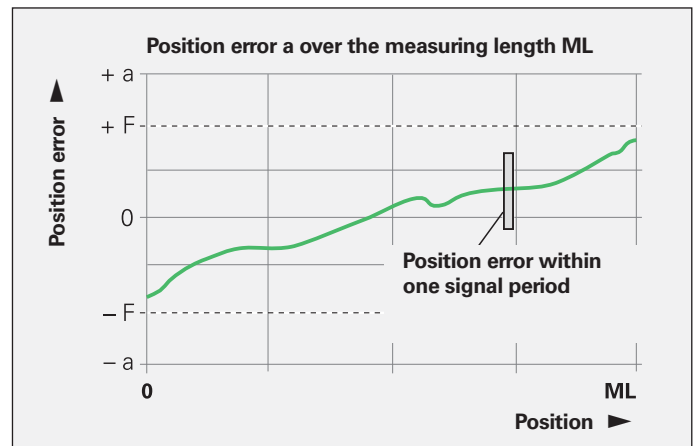

Position error within one signal period

The **position error u** within one signal period is determined by the signal period of the length gauge, as well as the quality of the graduation and the scanning thereof. At any position over the entire measuring length, it does not exceed approx. $\pm 1\%$ of the signal period.

The smaller the signal period, the smaller the position error within one signal period. In the calibration chart of the HEIDENHAIN-CERTO, this position error within one signal period is shown as a tolerance band.

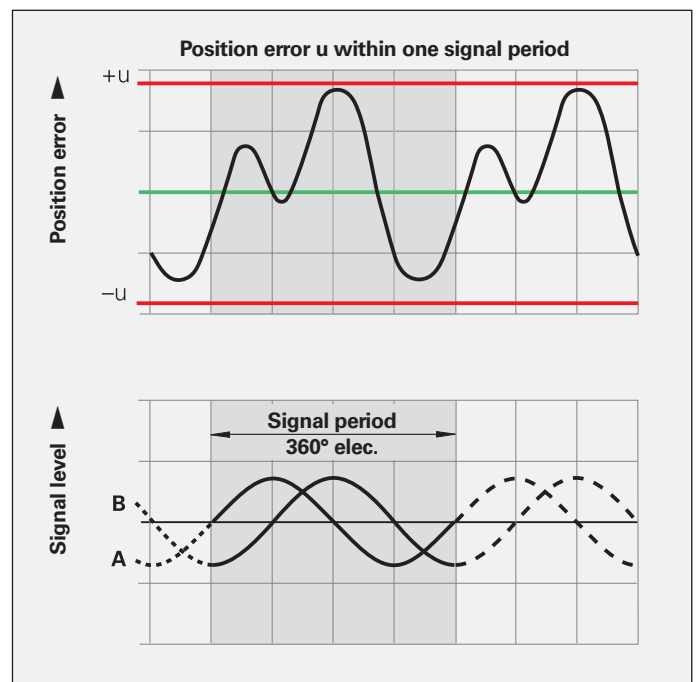

	Signal period of the scanning signals	Max. position error u within one signal period (approx.)
CT 2500 CT 6000	2 μm	$\pm 0.02 \mu\text{m}$
MT 1200 MT 2500	2 μm	$\pm 0.02 \mu\text{m}$
MT 60 MT 101	10 μm	$\pm 0.1 \mu\text{m}$
ST 1200 ST 3000	20 μm	$\pm 0.2 \mu\text{m}$
AT 1200	188.4 μm	$\pm 0.7 \mu\text{m}$

All HEIDENHAIN length gauges are inspected before shipping for accuracy and proper function.

They are calibrated for accuracy during retraction and extension of the plunger. For the HEIDENHAIN-CERTO, the number of measuring positions is selected to ascertain very exactly not only the long-range error, but also the position error within one signal period.

The **manufacturer's inspection certificate** confirms the specified system accuracy of each length gauge. The **calibration standards** ensure the traceability—as required by EN ISO 9001—to recognized national or international standards.

For the HEIDENHAIN-METRO and HEIDENHAIN CERTO series, a **calibration chart** documents the position error over the measuring range. It also shows the measuring step and the measuring uncertainty of the calibration measurement.

For the HEIDENHAIN-METRO the calibration chart shows the mean value of one forward and one backward measuring stroke.

The HEIDENHAIN-CERTO is represented in the calibration chart as the envelope curve of the measured error. The HEIDENHAIN-CERTO length gauges are supplied with two calibration charts, each for different operating attitudes.

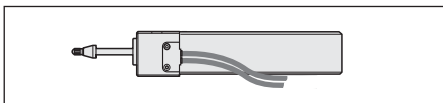

Operating attitude for calibration chart 1

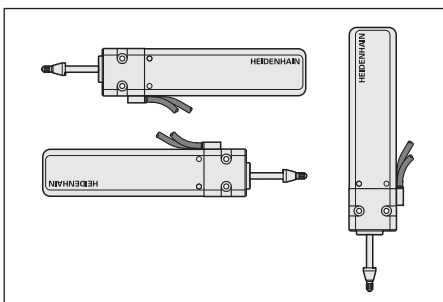

Operating attitude for calibration chart 2



Example

Temperature range

The length gauges are inspected at a **reference temperature** of 20 °C. The system accuracy given in the calibration chart applies at this temperature.

The **operating temperature** indicates the ambient temperature limits between which the length gauges will function properly. The **storage temperature range** of -20 °C to 60 °C applies for the device in its packaging.

Gauging Force—Plunger Actuation

Gauging force

Gauging force is the force that the plunger exercises on the measured object. An excessively large gauging force can cause deformation of the measuring contact and the measured object. If the gauging force is too small, an existing dust film or other obstacle may prevent the plunger from fully contacting the measured object. The gauging force depends on the type of plunger actuation.

Plunger actuation by spring

For the AT 1218, MT 12x1, MT 25x1, ST 12x8 and ST 30x8, the integral spring extends the plunger to the measuring position and applies the **gauging force**. In its resting position, the plunger is extended. The gauging force depends on the following criteria:

- The operating attitude
- The plunger position, because the gauging force changes over the measuring range
- The measuring direction, i.e., whether the gauge measures with extending or retracting plunger

In the diagrams, the measuring force is shown over the measuring range for a retracting and extending plunger in a horizontal operating attitude.

Plunger actuation by measured object

The complete length gauge is moved relative to the measured object. The measurement is made with retracting plunger.

Plunger actuation via cable-type lifter (MT 12x1, MT 25x1)

Through a cable mechanism, the plunger is retracted by hand and then extended onto the measured object. The measurement is made with extending plunger.

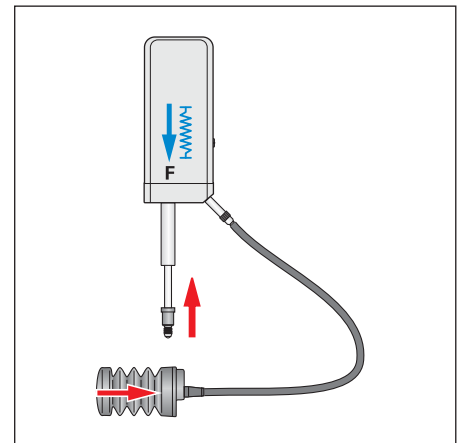
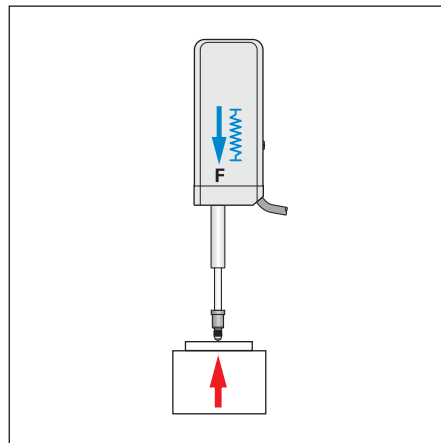

The diagrams apply for the **horizontal operating attitude**. The following compensation values are to be taken into account for other operating attitudes.

Model	Operating attitude vertically	
	Upward	Downward
AT 121x	-0.12 N	+0.12 N
MT 12xx	-0.13 N	+0.13 N
MT 25x1	-0.17 N	+0.17 N
MT 2587	-0.19 N	+0.19 N
ST 12x7	-0.07 N	+0.07 N
ST 12x8	-0.08 N	+0.08 N
ST 30xx	-0.11 N	+0.11 N

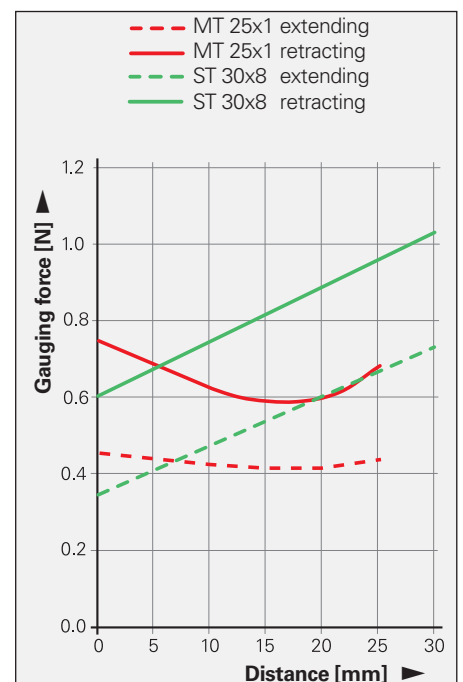
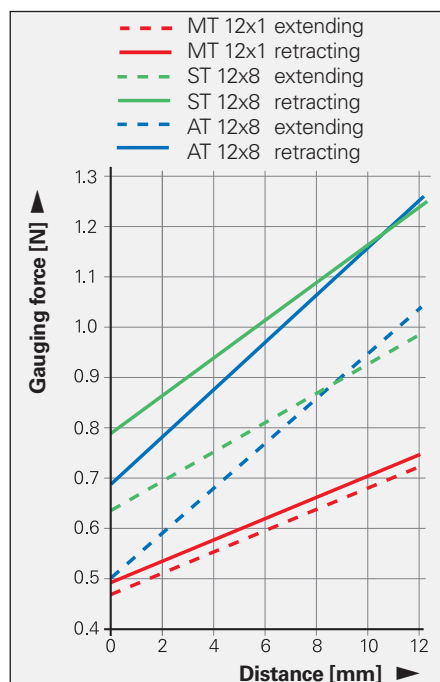

Pneumatic plunger actuation

The pneumatically actuated plungers of the AT 1217, MT 1287, MT 2587, ST 12x7 and ST 30x7 length gauges are extended by the application of compressed air. When the air connection is ventilated, the integral spring retracts the plunger to a protected resting position within the housing.

The **gauging force** can be adjusted to the measuring task through the level of air pressure. At constant pressure, it depends on the operating attitude and the plunger position.

The diagrams show the respective measuring force for a horizontal operating attitude depending on the compressed air applied with the plunger extending and retracting fully. These are approximate values that are subject to changes due to tolerances and depend on seal wear.

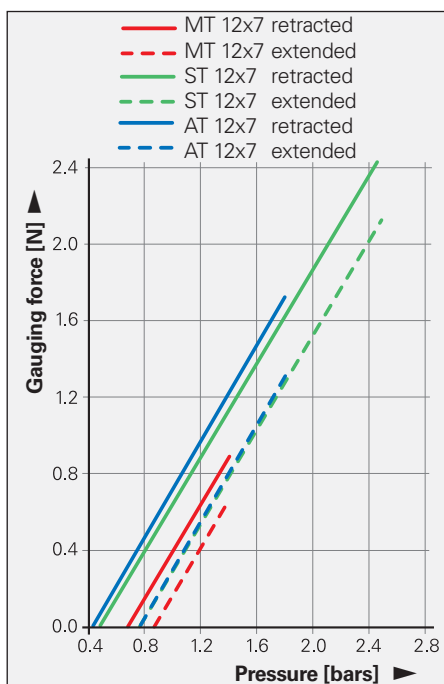
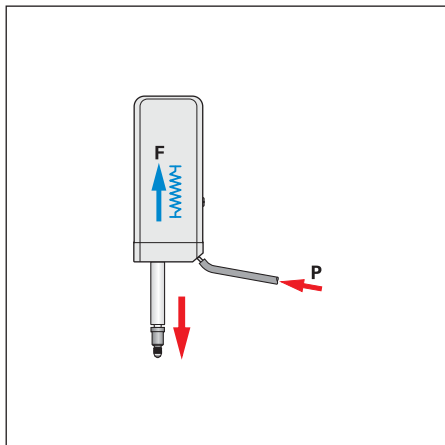

Motorized plunger actuation

The CT 2501, CT 6001, MT 60M and MT 101 M length gauges feature an integral motor that moves the plunger. It is operated through the switch box either by push button or over the connection for external actuation. The plungers of the CT 2501, CT 6001, and MT 60M length gauges must not be moved by hand if the switch box is connected.

The **gauging force** of the CT 2501, CT 6001, and MT 60M motorized length gauges is adjustable in three stages through the switch box. The force remains constant over the measuring range but depends on the operating attitude.

Regardless of the operating attitude—whether it measures vertically downward (with the SG 101V switchbox) or horizontally (with the SG 101 H switch box)—the MT 101 M exercises a constant gauging force.

Switch box and power adapter (only with MT101 M) must be ordered separately.

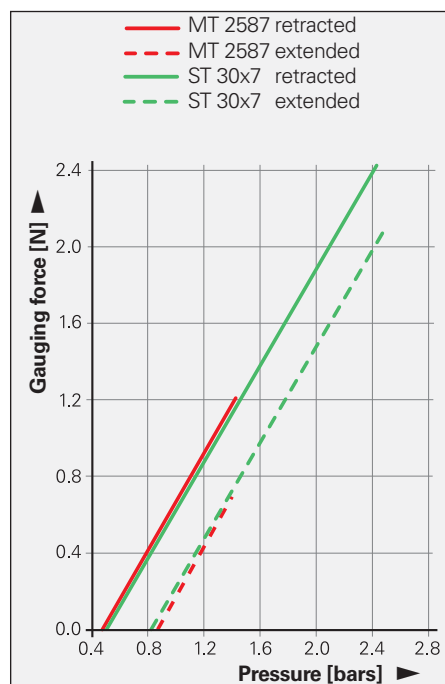
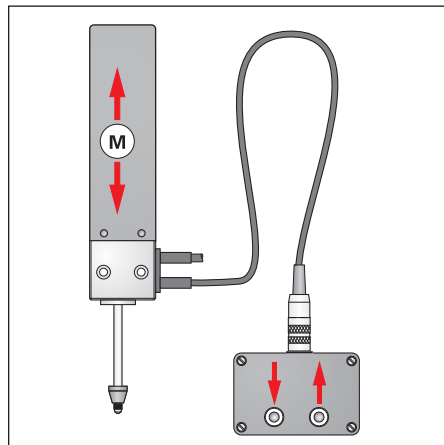

External plunger actuation by coupling

For the CT 2502, CT 6002, MT 60K, MT 101 K and special versions “without spring” of the MT 1200 and MT 2500, the plunger is freely movable. For position measurement, the plunger is connected by a coupling with a moving machine element. The force needed to move the plunger is specified as the required **moving force**. It depends on the operating attitude.

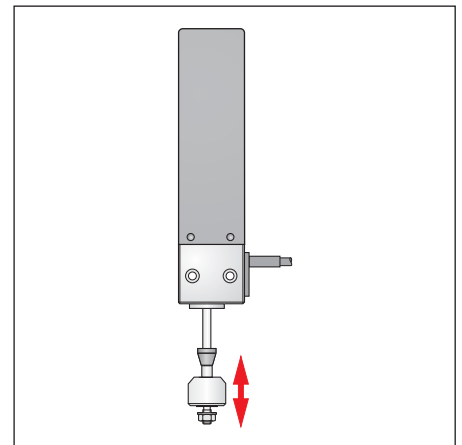

Note

The compressed air introduced directly into the length gauges must be properly conditioned and must comply with the following quality classes as per **ISO 8573-1** (1995 edition):

- Solid contaminant: Class 1 (max. particle size 0.1 μm and max. particle density 0.1 mg/m^3 at $1 \cdot 10^5$ Pa)
- Total oil content: Class 1 (max. oil concentration 0.01 mg/m^3 at $1 \cdot 10^5$ Pa)
- Maximum pressure dew point: Class 4, but with reference conditions of $+3$ °C at $2 \cdot 10^5$ Pa

HEIDENHAIN offers the **DA 400 Compressed Air Unit** for purifying compressed air.

For more information, ask for our **DA 400** Product Information sheet.

Mounting

In addition to the length gauge itself, the mechanical design of the measuring setup also plays a role in defining the quality of measurement.

Abbe principle

HEIDENHAIN length gauges enable you to work according to the Abbe measuring principle: The measured object and scale must be in alignment to avoid additional measuring error.

Measuring loop

All components included in the measuring loop such as the holder for the measured object, the gauge stand with holder, and the length gauge itself influence the result of measurement. Expansion or deformation of the measuring setup through mechanical or thermal influences adds directly to the error.

Mechanical design

A stable measuring assembly must be ensured. Long lateral elements within the measuring loop are to be avoided. HEIDENHAIN offers a stable gauge stand as an accessory.

The force resulting from the measurement must not cause any measurable deformation of the measuring loop. Incremental length gauges from HEIDENHAIN operate with small gauging force and have very little influence on the measuring setup.

Thermal behavior

Temperature variations during measurement cause changes in length or deformation of the measuring setup. After a change in temperature of 5 K, a steel bar of 200 mm length expands by 10 μm .

Length changes resulting from a uniform deviation from the reference temperature can largely be compensated by resetting the datum on the measuring plate or a master; only the expansion of the scale and measured object go into the result of measurement. Temperature changes during measurement cannot be ascertained mathematically.

For critical components, HEIDENHAIN therefore uses special materials with low coefficients of expansion, such as are found in the HEIDENHAIN-CERTO gauge stand. This makes it possible to guarantee the high accuracy of HEIDENHAIN-CERTO even at ambient temperatures of 19 to 21 °C and variations of ± 0.1 K during measurement.

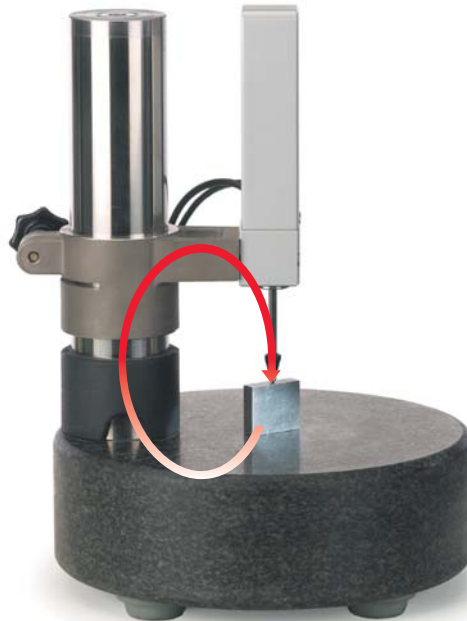

The measuring loop:

All components involved in the measuring assembly, including the length gauge

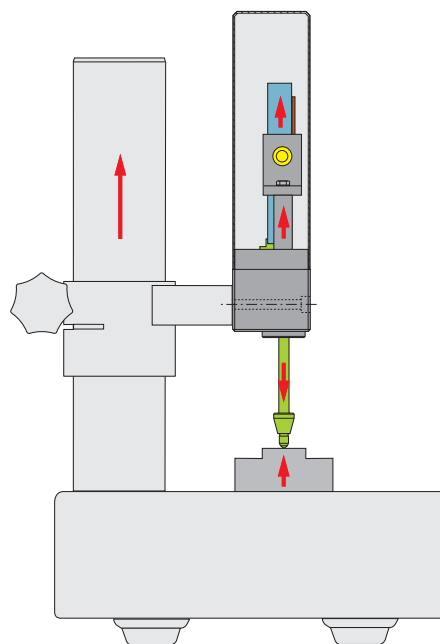

Thermally induced length change

Expansion of the measuring loop components as a result of heat

Acceleration

Shock and vibration of any kind is to be avoided during measurement so as not to impair the high accuracy of the length gauge.

The maximum values given in the specifications apply to the effect of external acceleration on the length gauge. They describe only the mechanical stability of the length gauge, and imply no guarantee of function or accuracy.

In the length gauge itself, unchecked extension of the spring-driven or non-coupled moving plunger can cause high acceleration onto the measured object or measuring plate surface. For the MT 1200 and MT 2500 series length gauges, use the cable-type lifter whenever possible (see *Accessories*). The cable lifter features adjustable pneumatic damping to limit the extension velocity to an uncritical value.

Fastening

The **CT 6000, MT 60** and **MT 101** length gauges are fastened by two screws onto a plane surface. This ensures a mechanically stable installation of even these large length gauges. Special holders are available for fastening the MT 60 and MT 101 to the MS 100 gauge stand for the HEIDENHAIN-METRO (see *Accessories*).

The **CT 2500** is mounted by its standard clamping shank with 16h8 diameter. A holder is available for fastening the HEIDENHAIN-CERTO to the gauge stand (see *Accessories*).

The **AT, ST, MT 1200** and **MT 2500** length gauges feature a standard clamping shank with 8h6 diameter. These HEIDENHAIN length gauges can therefore easily be used with existing measuring fixtures and stands.

As an accessory, HEIDENHAIN offers a special clamping sleeve and screw. It facilitates fastening the length gauge securely without overstressing the clamping shank.

Clamping sleeve ID 386811-01

Operating attitude for HEIDENHAIN-CERTO

The HEIDENHAIN-CERTO can be operated at any attitude. However, the mounting position with horizontal length gauge and upward facing mounting surface should be avoided because in such a case no guarantee can be made for accuracy.

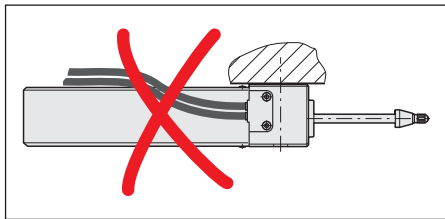

Orthogonal mounting

The length gauge is to be mounted so that its plunger is exactly orthogonal to the measured object or the surface on which it rests. Deviations result in measuring error. The accessory HEIDENHAIN gauge stands with holders for an **8 mm clamping shank** ensure orthogonal mounting. Length gauges that provide **planar mounting surfaces** are to be adjusted in the direction parallel to the mounting surface (Y) to be perpendicular to the measuring plate. A quick and reliable adjustment is possible with the aid of a gauge block or a parallel block. The perpendicularity to the measuring table (X) is already ensured by the gauge stand.

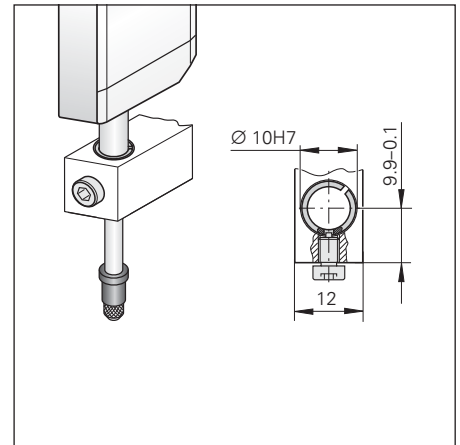
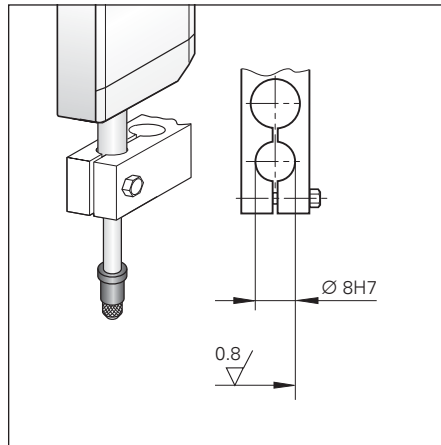
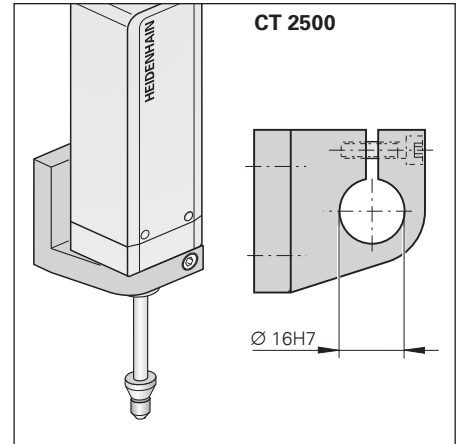
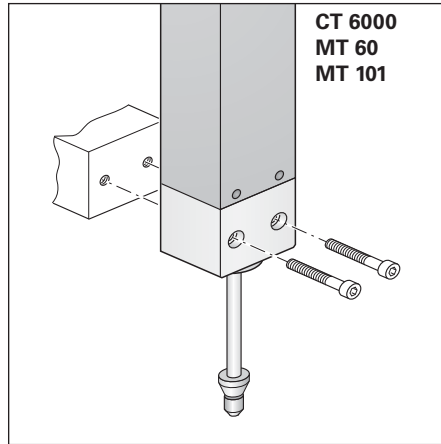

ACANTO

Absolute Length Gauges with EnDat Interface

- **Very compact dimensions**
- **Protected from splash water**

Thanks to their small dimensions, the ACANTO length gauges are the product of choice for multipoint inspection apparatus and testing equipment. Absolute position measurement provides the measured values immediately after switch-on. This is particularly favorable on measuring stations with numerous measuring points: as the measured value is already generated in the length gauge there is no need for the counting electronics for each measuring point that would otherwise be necessary.

Plunger actuation

The **AT 1218** length gauge features a spring-tensioned plunger that is extended at rest.

In the pneumatic length gauges **AT 1217**, the plunger is retracted to its rest position by the integral spring. It is extended to the measuring position by application of compressed air.

Mounting

The ACANTO length gauges are fastened by their 8h6 standard clamping shank.

Interface

The ACANTO length gauges have a bidirectional serial EnDat interface for transmission of the absolute position values and internal encoder information.

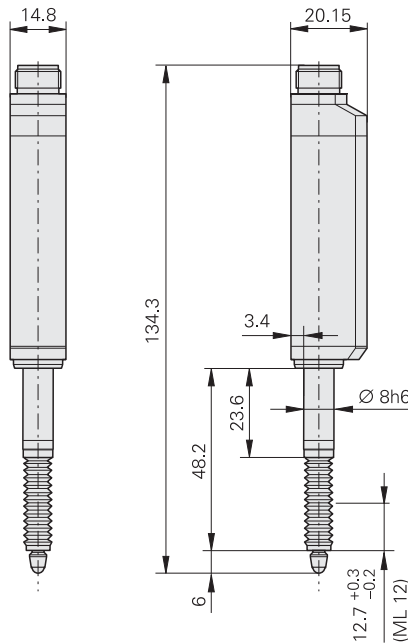

AT 1218

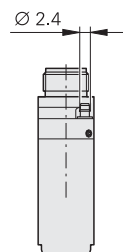

AT 1217

mm

 Tolerancing ISO 8015
 ISO 2768 - m H
 < 6 mm: ±0.2 mm

⊙ = Beginning of measuring length

Mechanical Data
Plunger actuation Position of plunger at rest
Measuring standard
System accuracy
Repeatability
Measuring range
Gauging force
Compressed air
Mech. permissible traversing speed
Radial force
Operating attitude
Vibration 55 Hz to 2000 Hz Shock 11 ms
Protection EN 60529
Operating temperature
Fastening
Weight without cable

Electrical Data
Absolute position values
Ordering designation
Resolution
Processing time
Electrical connection
Cable length
Power supply

AT 1218		AT 1217
By measured object Extended		Pneumatic Retracted
DIADUR grating on glass; grating period 188.4 µm		
± 2 µm		
± 0.1 µm according to DIN 32876 (in the cyclical, thermally balanced operating condition)		
12 mm		
See <i>Gauging Force—Plunger Actuation</i>		
–		≤ 1.8 bars
≤ 60 m/min		
≤ 0.5 N (mechanically permissible)		
Any		
≤ 100 m/s ² (EN 60068-2-6) ≤ 500 m/s ² (EN 60068-2-27)		
IP 67		IP 64 (IP 67 with sealing air)
10 to 40 °C; reference temperature 20 °C		
Clamping shank Ø 8h6		
80 g		

EnDat
EnDat 2.2
EnDat 22
23 nm
≤ 5 µs
M12 flange socket, axial
≤ 100 m with HEIDENHAIN cable
3.6 to 14 V DC / < 150 mA at 5 V

AT 1200



Specifications	CT 2501 CT 6001	CT 2502 CT 6002
Plunger actuation	By motor	Separate coupling with moving machine part
Measuring standard	DIADUR phase grating on Zerodur glass ceramic Grating period 4 µm	
System accuracy at 19 to 21 °C <i>CT 2500</i> <i>CT 6000</i>	± 0.1 µm without compensation; ± 0.03 µm after linear length error compensation ± 0.05 µm after linear length error compensation	
Recommd. measuring step	0.01 µm/0.005 µm (5 nm) with ND 28x	
Reference mark	Approx. 1.7 mm below upper stop	
Measuring range <i>CT 2500</i> <i>CT 6000</i>	25 mm 60 mm	
Gauging force Vertically downward Vertically upward Horizontal	1 N/1.25 N/1.75 N – /– /0.75 N – /0.75 N/1.25 N	–
Required moving force	–	0.1 N to 0.6 N (depending on operating attitude)
Radial force	≤ 0.5 N (mechanically permissible)	
Operating attitude	Any required (for preferred operating attitude see page 13)	
Vibration 55 Hz to 2000 Hz Shock 11 ms	≤ 100 m/s ² (EN 60068-2-6) ≤ 1000 m/s ² (EN 60068-2-27)	
Protection EN 60529	IP 50	
Operating temperature	10 to 40 °C; reference temperature 20 °C	
Fastening <i>CT 2500</i> <i>CT 6000</i>	Clamping shank Ø 16h8 Plane surface	
Weight <i>CT 2500</i> without cable <i>CT 6000</i>	520 g 700 g	480 g 640 g
Incremental signals	~ 11 µApp; signal period 2 µm	
Measuring velocity	≤ 24 m/min (depending on the subsequent electronics) ≤ 12 m/min with the ND 28x display unit	
Electrical connection*	<ul style="list-style-type: none"> • Cable, 1.5 m, with 15-pin D-sub connector • Cable, 1.5 m, with 9-pin M23 connector Interface electronics are integrated in connector.	
Cable length	≤ 30 m with HEIDENHAIN cable	
Power supply	5 V DC ± 5 %/< 180 mA	5 V DC ± 5 %/< 120 mA
Required accessories*	For CT 2501	For CT 6001
Switch box	SG 25M ID 317436-01	SG 60M ID 317436-02

CT 2500



CT 6000



* Please select when ordering

HEIDENHAIN-METRO

Length Gauges with $\pm 0.2 \mu\text{m}$ Accuracy

- High repeatability
- Plunger actuation by cable release, by the workpiece or pneumatically

With their high system accuracy and small signal period, the HEIDENHAIN-METRO MT 1200 and MT 2500 length gauges are ideal for precision measuring stations and testing equipment. They feature ball-bush guided plungers and therefore permit high radial forces.

Plunger actuation

The length gauges of the **MT 12x1** and **MT 25x1** series feature a spring-tensioned plunger that is extended at rest. In a special version without spring it exercises particularly low force on the measured object.

In the pneumatic length gauges **MT 1287** and **MT 2587**, the plunger is retracted to its rest position by the integral spring. It is extended to the measuring position by application of compressed air.

Mounting

The MT 1200 and MT 2500 length gauges are fastened by their 8h6 standard clamping shank. A mounting bracket is available as an accessory to mount the length gauges to plane surfaces or to the MS 200 from HEIDENHAIN.

Output signals

The MT 1200 and MT 2500 length gauges are available with various output signals.

The **MT 128x** and **MT 258x** length gauges provide sinusoidal voltage signals with **1V_{pp}** levels, which permit high interpolation.

The **MT 1271** and **MT 2571** feature integrated digitizing and interpolation electronics with 5-fold or 10-fold interpolation (as ordered) and square-wave signals in **TTL** levels.

MT 1287
MT 2587

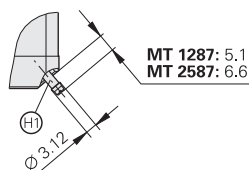

mm



Tolerancing ISO 8015
ISO 2768 - m H
< 6 mm: $\pm 0.2 \text{ mm}$

- ⊕ = Reference mark position
- ⊙ = Beginning of measuring length
- ⊕ = Air connection for 2 mm tube

MT 1200

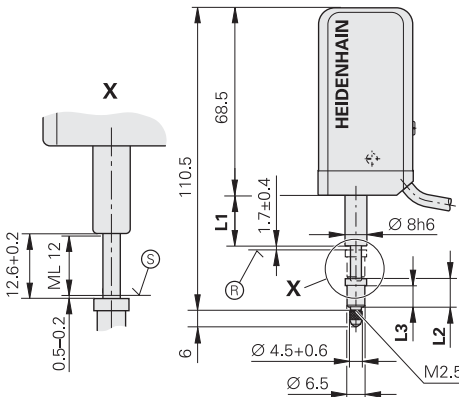
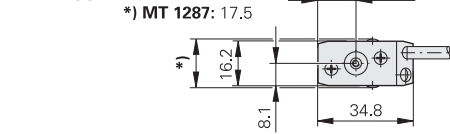

	MT 12x1	MT 1287
L1	18,5	22,0
L2	10,1	6,2
L3	8,1	4,2

MT 2500

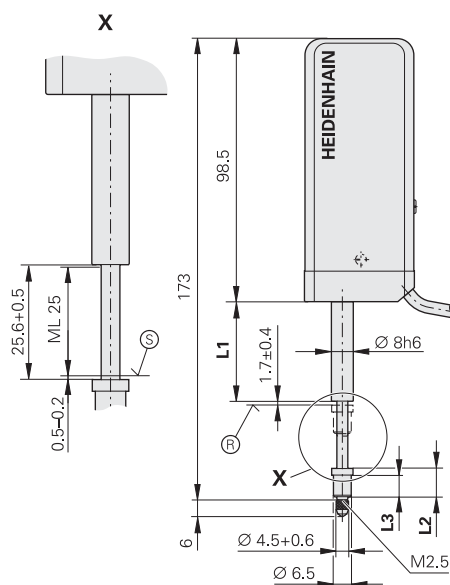
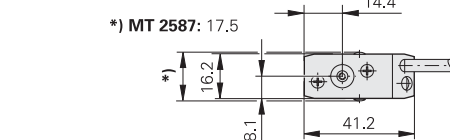

	MT 25x1	MT 2587
L1	37,0	41,0
L2	10,1	6,2
L3	8,1	4,2

Mechanical Data

Plunger actuation

Position of plunger at rest

Measuring standard

System accuracy

Reference mark

Measuring range

Gauging force

Version "without spring"
Vertically downward

Compressed air

Radial force

Operating attitude

Vibration 55 Hz to 2000 Hz
Shock 11 ms

Protection EN 60529

Operating temperature

Fastening

Weight without cable

Electrical Data

For length gauges

Incremental signals*

Signal period

Recommended measuring step

Mech. permissible traversing speed

Edge separation a at scanning frequency* / traverse speed

200 kHz	≤ 24 m/min
100 kHz	≤ 12 m/min
50 kHz	≤ 6 m/min
25 kHz	≤ 3 m/min







Electrical connection*

(Interface electronics integrated in connector)

Cable length





Power supply

* Please select when ordering

MT 1271  MT 1281 		MT 2571  MT 2581 		MT 1287 		MT 2587 	
By cable or measured object Extended				Pneumatic Retracted			
DIADUR phase grating on Zerodur glass ceramic; grating period 4 µm							
± 0.2 µm							
Approx. 1.7 mm below upper stop							
12 mm		25 mm		12 mm		25 mm	
See <i>Gauging Force—Plunger Actuation</i>							
0.13 N		0.17 N		–			
–				≤ 1.4 bars			
≤ 0.8 N (mechanically permissible)							
Any; Version “without spring”: Vertically downward							
≤ 100 m/s ² (EN 60068-2-6) ≤ 1000 m/s ² (EN 60068-2-27)							
IP 50				IP 64 (with sealing air)			
10 to 40 °C; reference temperature 20 °C							
Clamping shank Ø 8h6							
100 g		180 g		110 g		190 g	

MT 1200



 MT 1271 MT 2571		 MT 128x MT 258x	
 x 5 0.4 µm		 x 10 0.2 µm	
0.1 µm ¹⁾		0.05 µm ¹⁾	
≤ 30 m/min			
≥ 0.23 µs ≥ 0.48 µs ≥ 0.98 µs –		– ≥ 0.23 µs ≥ 0.48 µs ≥ 0.98 µs	
Cable, 1.5 m, with 15-pin D-sub connector		Cable 1.5 m with • D-sub connector, 15-pin • M23 connector, 12 pin	
≤ 30 m with HEIDENHAIN cable			
5 V DC ± 5 %/< 160 mA (without load)		5 V DC ± 5 %/< 130 mA	

MT 2500



¹⁾ After 4-fold evaluation

HEIDENHAIN-METRO

Length Gauges with $\pm 0.5 \mu\text{m}/\pm 1 \mu\text{m}$ Accuracy

- Large measuring ranges
- For dimensional and positional measurement

Large measuring ranges together with their high accuracy make the MT 60 and MT 101 HEIDENHAIN-METRO length gauges attractive for incoming inspection, production monitoring, quality control, or anywhere parts with very different dimensions are measured. But they are also easy to mount as highly accurate position encoders, for example on sliding devices or X-Y tables.

Plunger actuation

M version length gauges feature an integral motor that retracts and extends the plunger. While the MT 101 M operates at a constant gauging force, the MT 60 M allows you to select from three gauging force levels.

K version gauges have no integral plunger actuation. The plunger is freely movable. It can be connected to moving elements such as linear slides and X-Y table by a coupling (see *Accessories*).

Mounting

The length gauges are mounted onto a flat surface by two screws. The M versions can also be mounted in the MS 100 and MS 200 gauge stands.

Output signals

The MT 60 and MT 101 provide $\sim 11 \mu\text{A}_{\text{PP}}$ current signals for HEIDENHAIN subsequent electronics.

MT 60

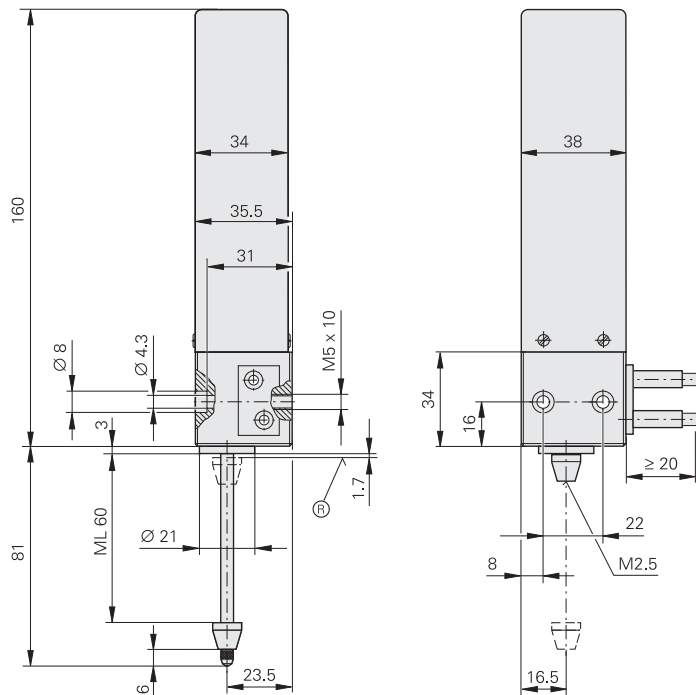

MT 101

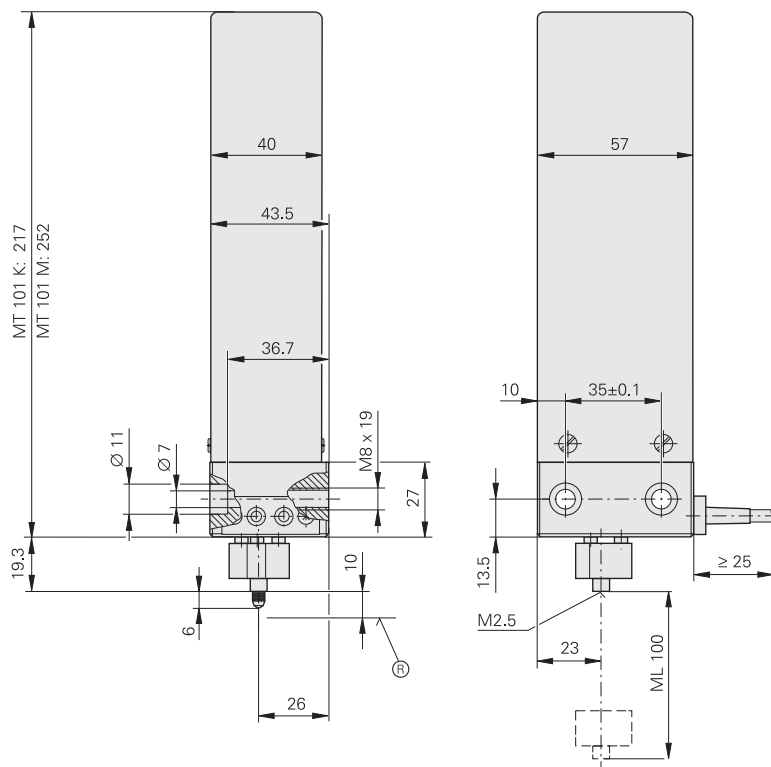

mm

 Tolerancing ISO 8015
 ISO 2768 - m H
 < 6 mm: $\pm 0.2 \text{ mm}$

⊗ = Reference mark position

Specifications	MT 60M MT 60K	MT 101M MT 101K
Plunger actuation <i>MT xxM</i> <i>MT xxK</i>	By motor Via separate coupling with moving machine part	
Measuring standard	DIADUR grating on silica glass; grating period 10 µm	
System accuracy	± 0.5 µm	± 1 µm
Recommd. measuring step	1 µm to 0.1 µm	
Reference mark	Approx. 1.7 mm from top	Approx. 10 mm from top
Measuring range	60 mm	100 mm
Gauging force Vertically downward Vertically upward Horizontal	With MT 60M 1 N/1.25 N/1.75 N – /– /0.75 N – /0.75 N/1.25 N	With MT 101 M 0.7 N with SG 101V – 0.7 N with SG 101 H
Required moving force with MT xxK	0.1 to 0.6 N (depends on operating attitude)	0.5 to 2 N (depends on operating attitude)
Radial force¹⁾	≤ 0.5 N	≤ 2 N
Operating attitude <i>MT xxM</i> <i>MT xxK</i>	Any Any	Vertically downward with SG 101V Horizontal with SG 101 H Any
Vibration 55 Hz to 2000 Hz Shock 11 ms	≤ 100 m/s ² (EN 60068-2-6) ≤ 1000 m/s ² (EN 60068-2-27)	
Protection EN 60529	IP 50	
Operating temperature	10 to 40 °C; reference temperature 20 °C	
Fastening	Plane surface	
Weight <i>MT xxM</i> without cable <i>MT xxK</i>	700 g 600 g	1400 g 1200 g
Incremental signals	~ 11 µAPP; signal period 10 µm	
Measuring velocity²⁾	≤ 18 m/min	≤ 60 m/min
Electrical connection* Cable length	<ul style="list-style-type: none"> • Cable, 1.5 m, with 15-pin D-sub connector; • Cable 1.5 m with 9-pin M23 connector (male); ≤ 30 m with HEIDENHAIN cable	
Power supply <i>MT xxM</i> <i>MT xxK</i> <i>Switch box</i>	5 V DC ± 5 %/< 120 mA 5 V DC ± 5 %/< 70 mA –	5 V DC ± 5 %/< 70 mA 5 V DC ± 5 %/< 70 mA Via power adapter
Required accessories*	For MT 60M	For MT 101M
Switch box	SG 60M	Vertical position: SG 101V Horizontal position: SG 101 H
Power supply unit 100 V AC to 240 V AC	–	ID 648029-01

MT 60M



MT 101M



* Please select when ordering
¹⁾ Mechanically permissible

²⁾ depending on the subsequent electronics

HEIDENHAIN-SPECTO

Length Gauges with $\pm 1 \mu\text{m}$ Accuracy

- Very compact dimensions
- Splash-proof

Thanks to their very small dimensions, the HEIDENHAIN-SPECTO length gauges are the product of choice for multipoint inspection apparatus and testing equipment.

Plunger actuation

The length gauges of the **ST 12x8** and **ST 30x8** series feature a spring-tensioned plunger that is extended at rest.

In the pneumatic length gauges **ST 12x7** and **ST 30x7** the plunger is retracted to its rest position by the integral spring. It is extended to the measuring position by application of compressed air.

Mounting

The HEIDENHAIN-SPECTO length gauges are fastened by their 8h6 standard clamping shank.

Output signals

The HEIDENHAIN-SPECTO length gauges are available with various output signals.

The **ST 128x** and **ST 308x** length gauges provide sinusoidal voltage signals with **1V_{PP}** levels, which permit high interpolation.

The **ST 127x** and **ST 307x** feature integrated digitizing and interpolation electronics with 5-fold or 10-fold interpolation (as ordered). They are transmitted as square-wave signals in **TTL** levels.

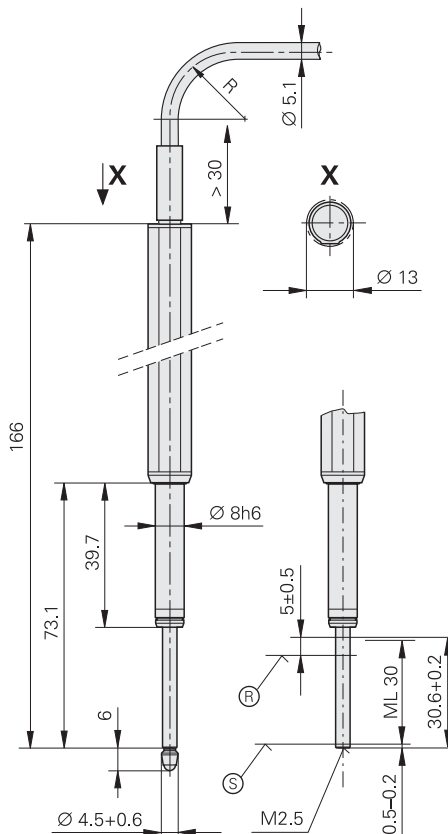
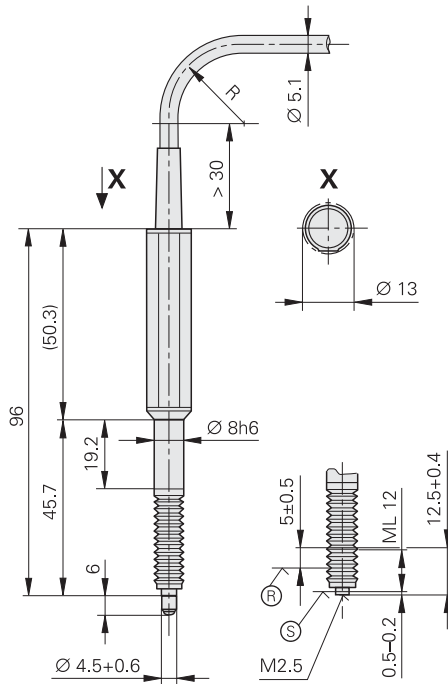

ST 12x7 ST 30x7

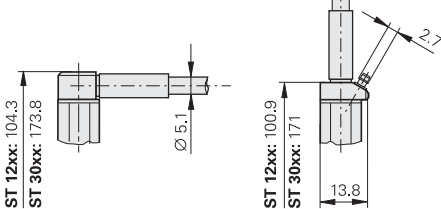

mm

 Tolerancing ISO 8015
 ISO 2768 - m H
 < 6 mm: $\pm 0.2 \text{ mm}$

Ⓡ = Reference mark position
 Ⓢ = Beginning of measuring length

Mechanical Data

Plunger actuation

Position of plunger at rest

Measuring standard

System accuracy

Reference mark

Measuring range

Gauging force

Compressed air

Radial force

Operating attitude

Vibration 55 Hz to 2000 Hz

Shock 11 ms

Protection

Operating temperature

Fastening

Weight

without cable

Electrical Data

For length gauges

Incremental signals*

Signal period

Recommended measuring step

Mech. permissible traversing speed

Edge separation a at scanning frequency*/traverse speed

100 kHz $\leq 72 \text{ m/min}^2$

50 kHz $\leq 60 \text{ m/min}$

25 kHz $\leq 30 \text{ m/min}$









Electrical connection*

Cable outlet*

Cable length





Power supply

* Please select when ordering

ST 1278  ST 1288  1 V _{PP}		ST 3078  ST 3088  1 V _{PP}		ST 1277  ST 1287  1 V _{PP}		ST 3077  ST 3087  1 V _{PP}	
By measured object Extended				Pneumatic Retracted			
DIADUR grating on glass; grating period 20 μm							
± 1 μm							
Approx. 5 mm below upper stop							
12 mm		30 mm		12 mm		30 mm	
See <i>Gauging Force—Plunger Actuation</i>							
–				≤ 2.5 bars			
≤ 0.8 N (mechanically permissible)							
Any							
≤ 100 m/s ² (EN 60068-2-6) ≤ 1000 m/s ² (EN 60068-2-27)							
IP 64 (for connecting elements see <i>Connecting Elements and Cables</i>)							
10 to 40 °C; reference temperature 20 °C							
Clamping shank Ø 8h6							
40 g		50 g		40 g		50 g	

ST 1200



 ST 127x ST 307x		 1 V _{PP} ST 128x ST 308x
 x 5 4 μm	 x 10 2 μm	 1 V _{PP} 20 μm
1 μm ¹⁾	0.5 μm ¹⁾	1 μm/0.5 μm
≤ 72 m/min		
≥ 0.48 μs ≥ 0.98 μs ≥ 1.98 μs	≥ 0.23 μs ≥ 0.48 μs ≥ 0.98 μs	–
Cable, 1.5 m, with 15-pin D-sub connector (interface electronics integrated)		Cable 1.5 m with • D-sub connector, 15-pin • M23 connector, 12 pin
Axial or radial		
≤ 30 m with HEIDENHAIN cable		
5 V DC ± 10 %/< 230 mA (without load)		5 V DC ± 10 %/< 90 mA

ST 3000



¹⁾ After 4-fold evaluation
²⁾ Mechanically limited

Accessories

Measuring Contacts

Ball-type contact

Steel ID 202504-01
 Carbide ID 202504-02
 Ruby ID 202504-03

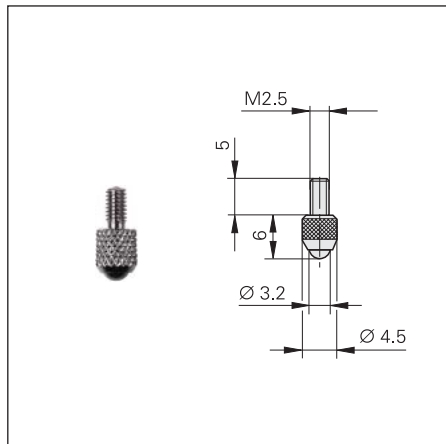

Domed contact

Carbide ID 229232-01

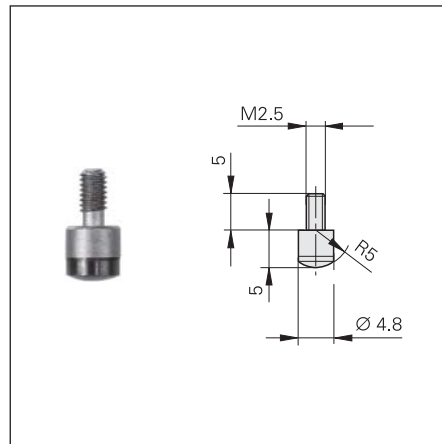

Flat contact

Steel ID 270922-01
 Carbide ID 202506-01

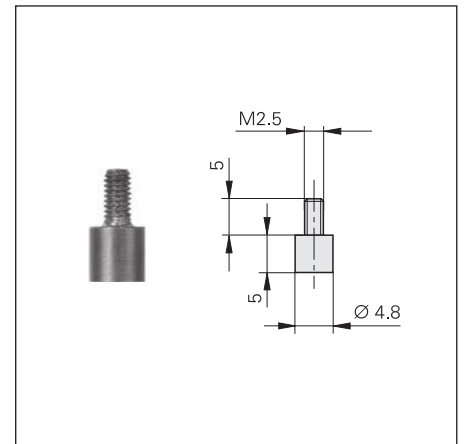

Pin-type contact

Steel ID 202505-01

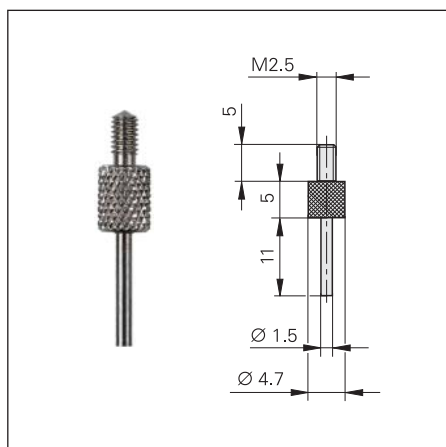

Knife-edge contact

Steel ID 202503-01

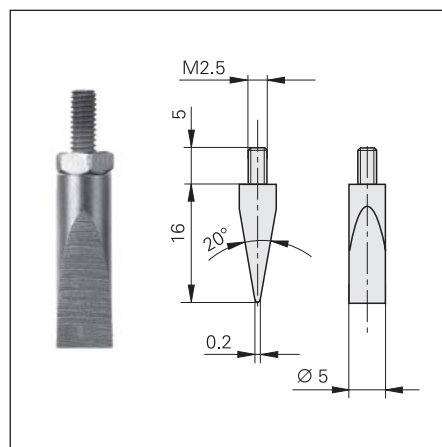

mm
 Tolerancing ISO 8015
 ISO 2768 - m H
 < 6 mm: ±0.2 mm

Roller contact, steel

For a low-friction contact with moving surfaces

Crowned ID 202502-03
 Cylindrical ID 202502-04

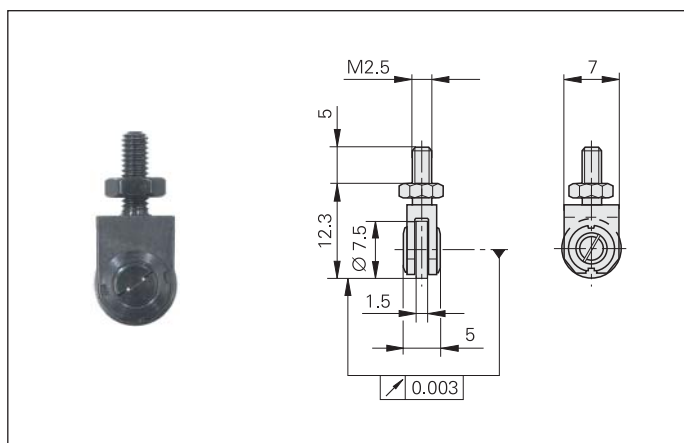

Adjustable contact, carbide

For exact parallel alignment to the measuring plate surface

Flat ID 202507-01
 Knife-edged ID 202508-01

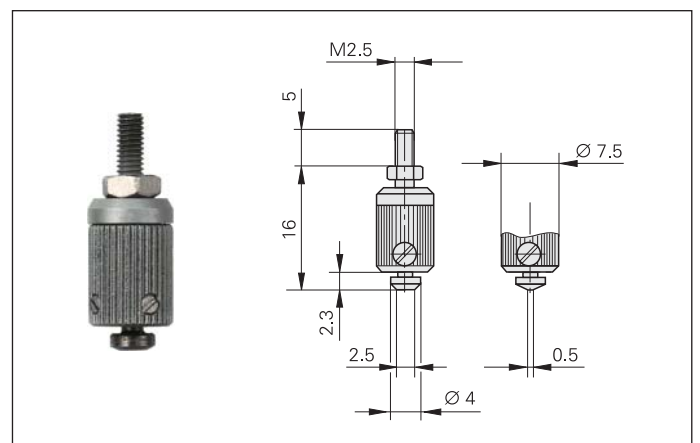

Switch Boxes, Coupling

Switch boxes for CT 2501, CT 6001, MT 60M, MT 101 M

Switch boxes are required for length gauges with motorized plunger actuation. The plunger is controlled through two push buttons or by external signal. The gauging force is adjustable at the SG 25M and SG 60M switch boxes in three stages.

SG 25M

ID 317436-01

SG 60M

ID 317436-02

SG 101V¹⁾

For the MT 101 M in vertical operation
ID 361140-01

SG 101H¹⁾

For the MT 101 M in horizontal operation
ID 361140-02

Connector (female) 3-pin

For external operation of the switch box
ID 340646-05

¹⁾ Separate power supply required

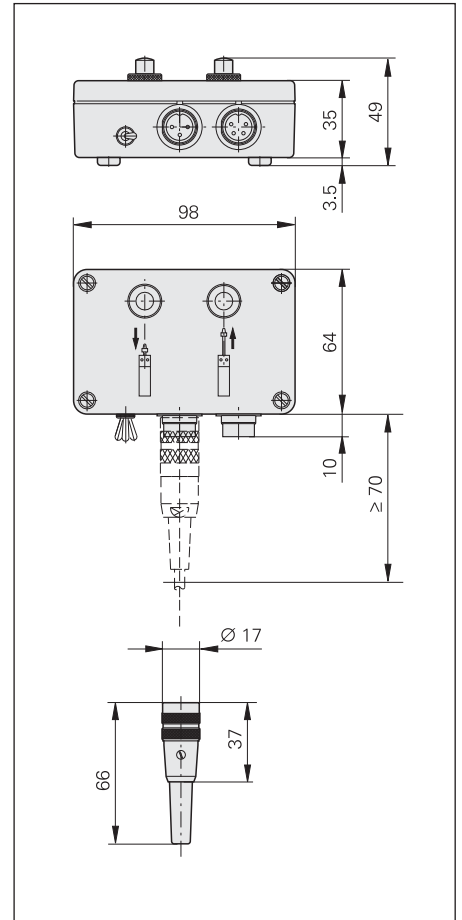

Power adapter for SG 101V/H

An adapter connected to the switch box powers the MT 101 M.

Voltage range 100 to 240 V AC
Exchangeable plug adapter (U.S. and Euro connectors included in delivery)

ID 648029-01

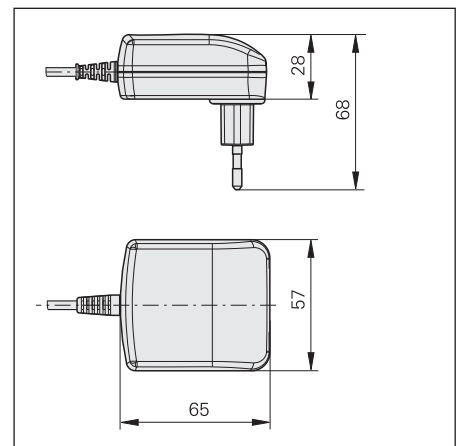

Coupling

For connecting the plunger of the length gauge (specifically for the MT 60K, MT 101 K, CT 2502 and CT 6002) to a moving machine element

ID 206310-01

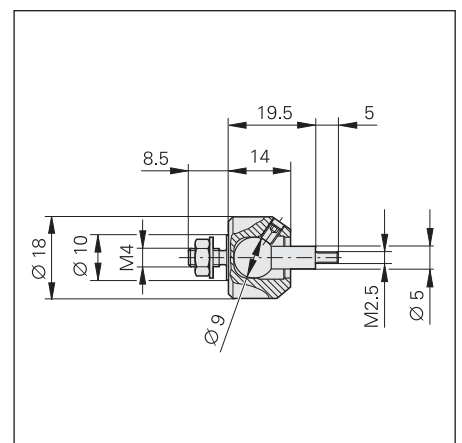

mm
Tolerancing ISO 8015
ISO 2768 - m H
< 6 mm: ±0.2 mm

Accessories for HEIDENHAIN-CERTO Gauge Stand

CS 200 gauge stand

For length gauges CT 2501*
CT 6001

ID 221310-01

Overall height 349 mm
Base \varnothing 250 mm
Column \varnothing 58 mm
Weight 15 kg

*) With special holder

The flatness of the CS 200 is determined with the aid of a Fizeau interferometer.

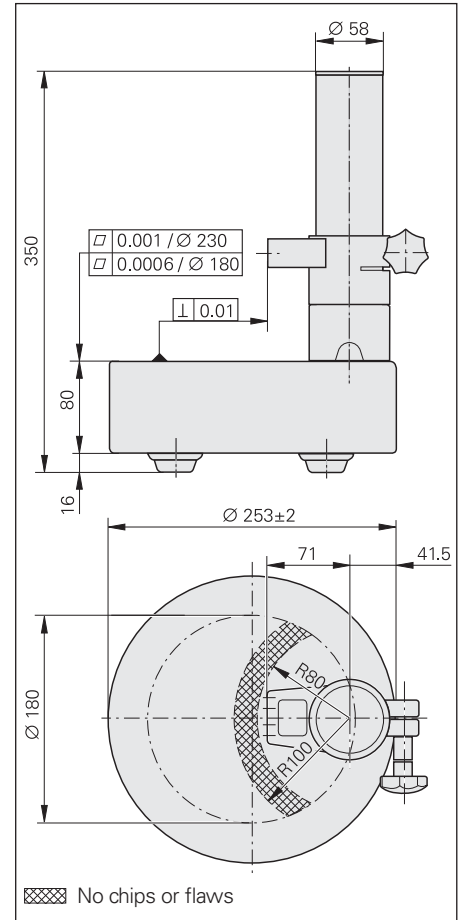

Holder for CS 200

For the CT 2501 with \varnothing 16 mm clamping shank

ID 324391-01

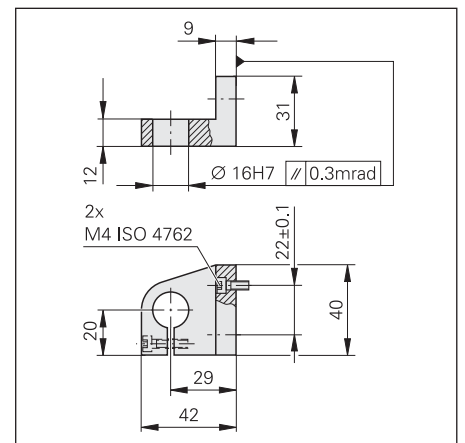

mm

 Tolerancing ISO 8015
 ISO 2768 - m H
 < 6 mm: \pm 0.2 mm

Ceramic Suction Plate, Diaphragm Pump

Ceramic suction plate

Wear-resistant working surface with high surface quality specifically for inspecting gauge blocks

ID 223100-01

The gauge block (class 1 or 2)—or any other object with a plane surface—is drawn by suction onto the top of the ceramic plate. The ceramic plate is likewise drawn to the granite base and held in place through negative gauge pressure.

Parts for connecting the ceramic suction plate with the diaphragm pump are among the items supplied:

Pressure tubing 3 m
T-joint
Connecting piece

Diaphragm pump

Source of suction for drawing the measured object and ceramic suction plate

Power consumption 20 W
Weight 2.3 kg
Line voltage 230 V AC/50 Hz
ID 754220-01

Line voltage 115 V AC/60 Hz
ID 754220-02

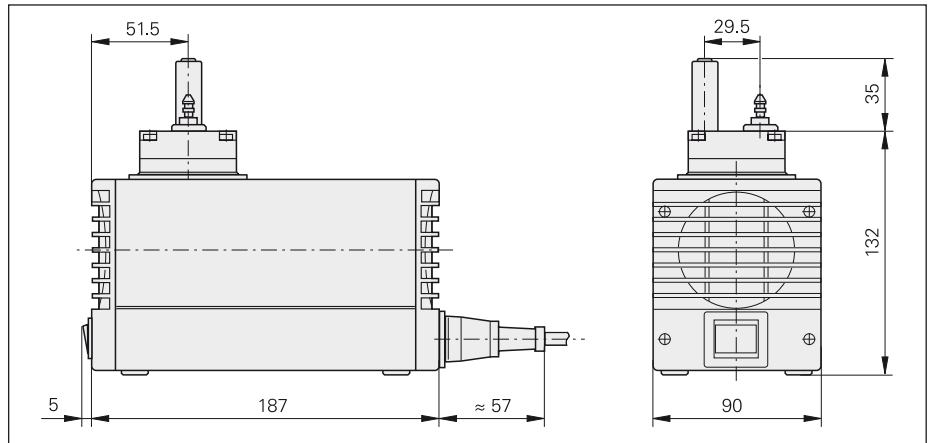
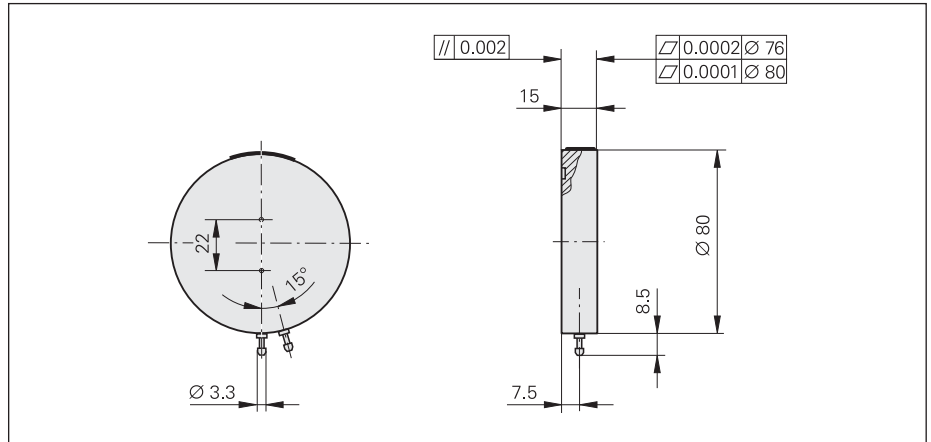

mm

 Tolerancing ISO 8015
 ISO 2768 - m H
 < 6 mm: ± 0.2 mm

Accessories for ACANTO, HEIDENHAIN-METRO and HEIDENHAIN-SPECTO Cable-Type Lifter, Gauge Stands

Cable lifter

For manual plunger actuation of MT 1200 and MT 2500.

The integral pneumatic damping reduces the plunger extension speed to prevent rebounding, for example on very hard materials.

ID 257790-01

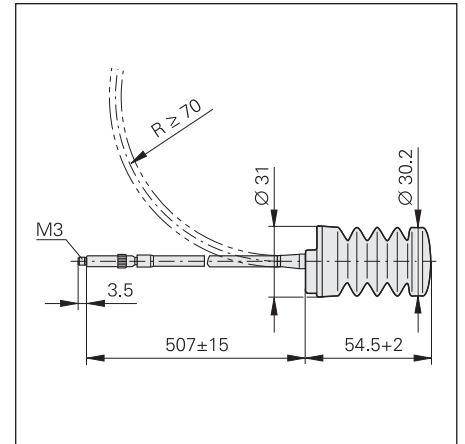

MS 200 gauge stand

For length gauges AT¹⁾
ST¹⁾
MT 1200¹⁾
MT 2500¹⁾
MT 60M
MT 101 M

ID 244154-01

Overall height 346 mm
Base Ø 250 mm
Column Ø 58 mm
Weight 18 kg

¹⁾ With special holder

Holder for MS 200

For mounting the length gauges with Ø 8 mm clamping shank, e.g. AT, ST, MT 1200, MT 2500

ID 324391-02

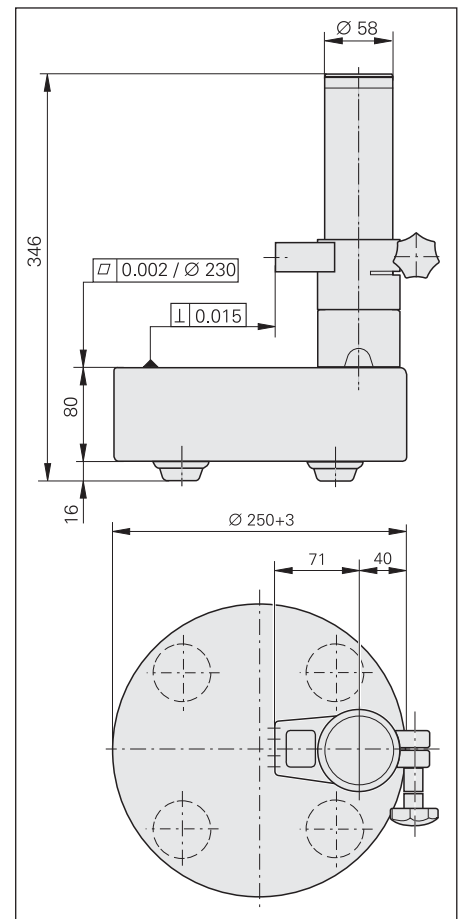

Clamping sleeve

For length gauges AT, ST
MT 1200
MT 2500

For fixing the length gauge reliably without overloading the 8h6 clamping shank.

Consisting of:

Sleeve, clamping screw

ID 386811-01 (1 unit per package)

ID 386811-02 (10 units per package)

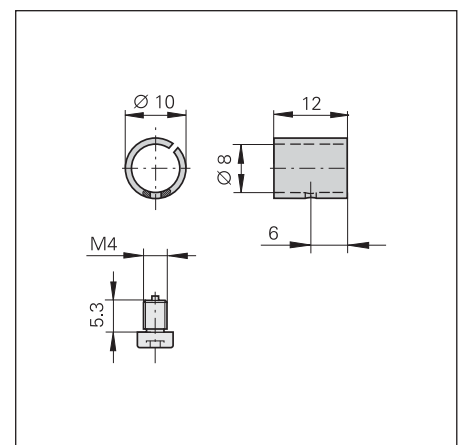

mm



Tolerancing ISO 8015

ISO 2768 - m H

< 6 mm: ±0.2 mm

MS 45 gauge stand

For length gauges AT,
ST
MT 1200
MT 2500

ID 202162-02

Overall height 196.5 mm
Base Ø 49 mm
Column Ø 22 mm
Weight 2.2 kg

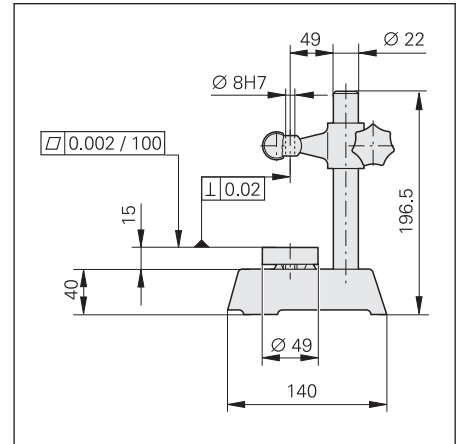

MS 100 gauge stand

For length gauges AT,
ST
MT 1200
MT 2500
MT 60M¹⁾
MT 101M¹⁾

ID 202164-02

Overall height 385 mm
Measuring plate 100 mm x 115 mm
Column Ø 50 mm
Weight 18 kg

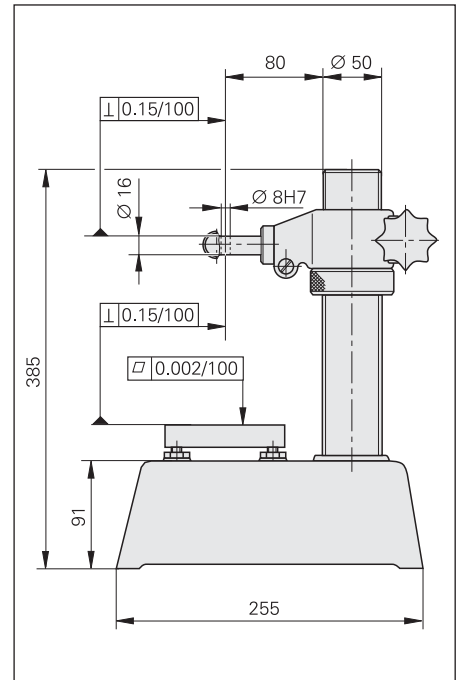

¹⁾ With special holder

Holder for MS 100

For mounting the MT 60M
ID 207479-01

For mounting the MT 101M
ID 206260-01

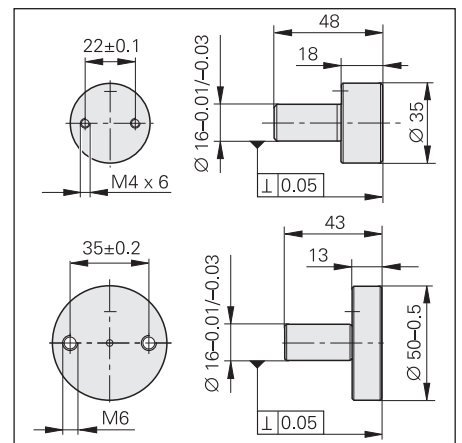

mm
Tolerancing ISO 8015
ISO 2768 - m H
< 6 mm: ±0.2 mm

Digital Readouts

ND 200

Digital readout for one axis

HEIDENHAIN encoders with 11 μAPP or 1 V_{PP} signals and EnDat 2.2 interface can be connected to the digital readouts of the ND 200 series. The **ND 280** readout provides the basic functions for simple measuring tasks. The **ND 287** also features other functions such as sorting and tolerance check mode, minimum/maximum value storage, measurement series storage. It calculates the mean value and standard deviations and creates histograms and control charts. The ND 287 permits optional connection of a second encoder for sum/difference measurement or of an analog sensor.

The ND 28x units have serial interfaces for measured value transfer.



For more information, see the *Digital Readouts/Linear Encoders* brochure.

	ND 280	ND 287
Encoder input ¹⁾	1 x \sim 11 μAPP , \sim 1 V_{PP} or EnDat 2.2	
Connection	D-sub, 15-pin, female	
Input frequency	\sim 1 V_{PP} : \leq 500 kHz; 11 μAPP : \leq 100 kHz	
Signal subdivision	Up to 4096-fold (adjustable)	
Display step (adjustable)	<i>Linear axis:</i> 0.5 to 0.002 μm <i>Angular axis:</i> 0.5° to 0.00001° and/or 00°00'00.1"	
Functions	<ul style="list-style-type: none"> REF reference mark evaluation 2 datums 	
	–	<ul style="list-style-type: none"> Sorting and tolerance checking Measurement series (max. 10000 measured values) Minimum/maximum value storage Statistics functions Sum/difference display (option)
Switching I/O	–	Yes
Interface	RS-232-C/V.24; USB (UART); Ethernet (option for ND 287)	

¹⁾ Automatic detection of interface

ND 2100 G GAGE-CHEK

Digital Readouts

The ND 2100 G GAGE-CHEK readouts are versatile metrology displays for measuring and inspection tasks in manufacturing and quality assurance. With inputs for up to eight encoders, they are predestined for multipoint measurements from simple pass/fail detection up to complex SPC evaluation.



For more information see *Digital Readouts for Metrology Applications* brochure

	ND 2100G GAGE-CHEK		
Input signals*	\sim 1 V_{PP}	\square TTL	EnDat 2.2
Encoder inputs	D-sub (15-pin) male	D-sub (9-pin) male	M12 flange socket (8-pin) female
Number of inputs*	<i>ND 2104 G:</i> 4 <i>ND 2108 G:</i> 8		
Signal evaluation/subdivision	10-fold	4-fold	–
Display	5.7" color flat-panel display		
Functions	<ul style="list-style-type: none"> Part programming of up to 100 parts Sorting and tolerance checking using tolerance and warning limits Measurement series with MIN/MAX display Mathematical and trigonometric formulas, logical operations Functions for statistical process control (SPC) Graphic display (measurement results, distribution) Data storage of values and formulas 		
Switching I/O	Yes		
Interface	<ul style="list-style-type: none"> RS-232-C/V.24 USB 		

Evaluation Electronics

MSE 1000 Modular Electronic Unit for Multipoint Inspection Apparatuses

The MSE 1000 of HEIDENHAIN is a higher level electronics unit in modular design for multipoint inspection apparatuses. The individual modules permit connection of incremental, absolute and analog measurands, the output of switch signals, and communication over diverse interfaces. In all, up to 250 axes or channels can be configured. This gives it the flexibility required to adapt to differing operating conditions.

In its basic configuration, the MSE 1000 consists of a power module and a basic module. It can be expanded by further modules as needed.



For more information, see the *MSE 1000* Product Information sheet.

		MSE 1000
Measuring channels/axes		Up to 250
Modules	Basic	<ul style="list-style-type: none"> • Ethernet 10/100 to the PC • Four encoder inputs with EnDat 2.2, TTL or 1 V_{PP} • Switching input TTL
	Power supply	100 to 240 V AC or 24 V DC
	EnDat	4 or 8 EnDat-2.2 encoder inputs
	Sinusoidal	4 or 8 encoder inputs with 1 V _{PP}
	Square wave	4 or 8 TTL encoder inputs
	Analog	Two analog inputs
	I/O	4 relay outputs and 4 switching inputs TTL
	Compressed air	Air switch for pneumatic length gauges
	Mounting	On top hat rail on mounting stand or in electrical cabinets
Software	<ul style="list-style-type: none"> • MSEsetup • Ethernet driver 	
Interface	Standard Ethernet, IEEE 802.3	

Sample units immediately available; series production planned for 3rd quarter 2012

EIB 741 External interface box

The EIB 741 is ideal for applications requiring high resolution, fast measured-value acquisition, mobile data acquisition or data storage.

Up to four incremental or absolute HEIDENHAIN encoders can be connected to the EIB 741. The data is output over a standard Ethernet interface.



For more information, see the *EIB 741* Product Information sheet.

		EIB 741	
Encoder inputs switchable	~ 1 V _{PP}	EnDat 2.1	EnDat 2.2
Connection	Four D-sub connections (15-pin, female)		
Input frequency	≤ 500 kHz	–	
Signal subdivision	4096-fold	–	
Internal memory	Typically 250 000 position values per input		
Interface	Ethernet as per IEEE 802.3 (≤ 1 gigabit)		
Driver software and demo program	For Windows, Linux, LabView Program examples		

IK 220

Universal PC counter card

The IK 220 is an expansion board for PCs for recording the measured values of two incremental or absolute HEIDENHAIN encoders. The subdivision and counting electronics subdivide the sinusoidal input signals 4096-fold. A driver software package is included in delivery.



For more information, see the *IK 220* Product Information sheet.

	IK 220			
Encoder inputs switchable	~ 1 V _{PP}	~ 11 μA _{PP}	EnDat 2.1	SSI
Connection	Two D-sub connections (15-pin, male)			
Input frequency	≤ 500 kHz	≤ 33 kHz	–	
Signal subdivision	4096-fold		–	
Internal memory	8192 position values per input			
Interface	PCI bus (plug and play)			
Driver software and demo program	For Windows 2000/XP/Vista/7 in VISUAL C++, VISUAL BASIC and BORLAND DELPHI			

Interfaces

Incremental Signals $\sim 11 \mu\text{A}_{\text{PP}}$

HEIDENHAIN encoders with $\sim 11 \mu\text{A}_{\text{PP}}$ interface provide current signals. They are intended for connection to ND position display units or EXE pulse-shaping electronics from HEIDENHAIN.

The sinusoidal **incremental signals** I_1 and I_2 are phase-shifted by 90° elec. and have signal levels of approx. $11 \mu\text{A}_{\text{PP}}$.

The illustrated sequence of output signals— I_2 lagging I_1 —applies for the retracting plunger.

The **reference mark signal** I_0 has a usable component G of approx. $5.5 \mu\text{A}$.

The data on **signal amplitude** apply when the power supply given in the *Specifications* is connected at the encoder. They refer to a differential measurement between the associated outputs. The signal amplitude decreases with increasing frequency. The **cutoff frequency** indicates the scanning frequency at which a certain percentage of the original signal amplitude is maintained:

- -3 dB cutoff frequency: 70 % of the signal amplitude
- -6 dB cutoff frequency: 50 % of the signal amplitude

Interpolation/resolution/measuring step

The output signals of the $11 \mu\text{A}_{\text{PP}}$ interface are usually interpolated in the subsequent electronics in order to attain sufficiently high resolutions.

Measuring steps for **position measurement** are recommended in the *Specifications*. For special applications, other resolutions are also possible.

Interface	Sinusoidal current signals $\sim 11 \mu\text{A}_{\text{PP}}$
Incremental signals	2 nearly sinusoidal signals I_1 and I_2 Signal amplitude M: 7 to $16 \mu\text{A}_{\text{PP}}$ /typically $11 \mu\text{A}_{\text{PP}}$ Asymmetry IP – NI/2M: ≤ 0.065 Amplitude ratio M_A/M_B : 0.8 to 1.25 Phase angle $ \varphi_1 + \varphi_2 /2$: $90^\circ \pm 10^\circ$ elec.
Reference-mark signal	1 or several signal peaks I_0 Usable component G: 2 to $8.5 \mu\text{A}$ Switching threshold E, F: $\geq 0.4 \mu\text{A}$ Zero crossovers K, L: $180^\circ \pm 90^\circ$ elec.
Connecting cable	Shielded HEIDENHAIN cable PUR $[3(2 \cdot 0.14 \text{ mm}^2) + (2 \cdot 1 \text{ mm}^2)]$ Cable length: Max. 30 m with 90 pF/m distributed capacitance Propagation time: 6 ns/m

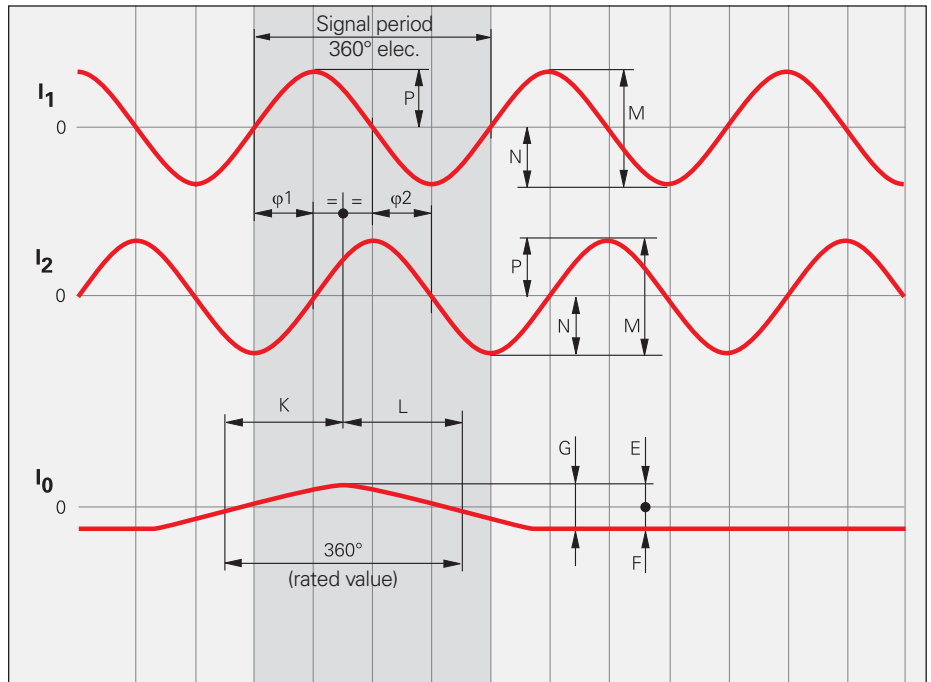

Pin Layout

9-pin HEIDENHAIN connector				15-pin D-sub connector						
				For ND 28x/PWM 20 or on encoder						
	Power supply			Incremental signals						
	3	4	Housing	9	1	2	5	6	7	8
	4	2		6	1	9	3	11	14	7
	U_P	0V	External shield	Internal shield	$I_1 +$	$I_1 -$	$I_2 +$	$I_2 -$	$I_0 +$	$I_0 -$
	Brown	White	–	White/Brown	Green	Yellow	Blue	Red	Gray	Pink

U_P = Power supply

Vacant pins or wires must not be used!

Shield on housing.

Color assignment applies only to extension cable.

Interfaces

Incremental Signals $\sim 1 V_{PP}$

HEIDENHAIN encoders with $\sim 1 V_{PP}$ interface provide voltage signals that can be highly interpolated.

The sinusoidal **incremental signals** A and B are phase-shifted by 90° elec. and have amplitudes of typically $1 V_{PP}$. The illustrated sequence of output signals—with B lagging A—applies for the direction of motion shown in the dimension drawing.

The **reference mark signal** R has a usable component G of approx. $0.5 V$. Next to the reference mark, the output signal can be reduced by up to $1.7 V$ to a quiescent value H. This must not cause the subsequent electronics to overdrive. Even at the lowered signal level, signal peaks with the amplitude G can also appear.

The data on **signal amplitude** apply when the power supply given in the specifications is connected to the encoder. They refer to a differential measurement at the 120 ohm terminating resistor between the associated outputs. The signal amplitude decreases with increasing frequency. The **cutoff frequency** indicates the scanning frequency at which a certain percentage of the original signal amplitude is maintained:

- $-3 \text{ dB} \triangleq 70 \%$ of the signal amplitude
- $-6 \text{ dB} \triangleq 50 \%$ of the signal amplitude

The data in the signal description apply to motions at up to 20% of the -3 dB -cutoff frequency.

Interpolation/resolution/measuring step

The output signals of the $1 V_{PP}$ interface are usually interpolated in the subsequent electronics in order to attain sufficiently high resolutions. For **velocity control**, interpolation factors are commonly over 1000 in order to receive usable velocity information even at low speeds.

Measuring steps for **position measurement** are recommended in the specifications. For special applications, other resolutions are also possible.

Short-circuit stability

A temporary short circuit of one signal output to $0 V$ or U_P (except encoders with $U_{Pmin} = 3.6 V$) does not cause encoder failure, but it is not a permissible operating condition.

Short circuit at	$20^\circ C$	$125^\circ C$
One output	< 3 min	< 1 min
All outputs	< 20 s	< 5 s

Interface	Sinusoidal voltage signals $\sim 1 V_{PP}$
Incremental signals	2 nearly sinusoidal signals A and B Signal amplitude M: 0.6 to $1.2 V_{PP}$; typically $1 V_{PP}$ Asymmetry $ P - N /2M$: ≤ 0.065 Amplitude ratio M_A/M_B : 0.8 to 1.25 Phase angle $ \varphi_1 + \varphi_2 /2$: $90^\circ \pm 10^\circ$ elec.
Reference-mark signal	One or several signal peaks R Usable component G: $\geq 0.2 V$ Quiescent value H: $\leq 1.7 V$ Switching threshold E, F: 0.04 to $0.68 V$ Zero crossovers K, L: $180^\circ \pm 90^\circ$ elec.
Connecting cable	Shielded HEIDENHAIN cable PUR $[4(2 \times 0.14 \text{ mm}^2) + (4 \times 0.5 \text{ mm}^2)]$ Max. 150 m at 90 pF/m distributed capacitance Propagation time 6 ns/m

These values can be used for dimensioning of the subsequent electronics. Any limited tolerances in the encoders are listed in the specifications. For encoders without integral bearing, reduced tolerances are recommended for initial operation (see the mounting instructions).

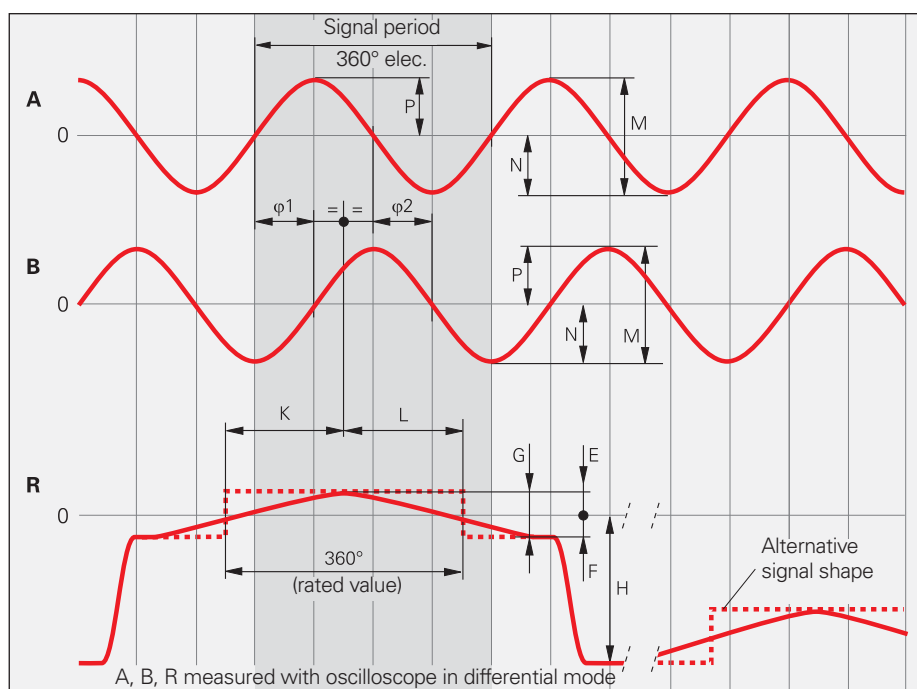

Cutoff frequency

Typical signal amplitude curve with respect to the scanning frequency

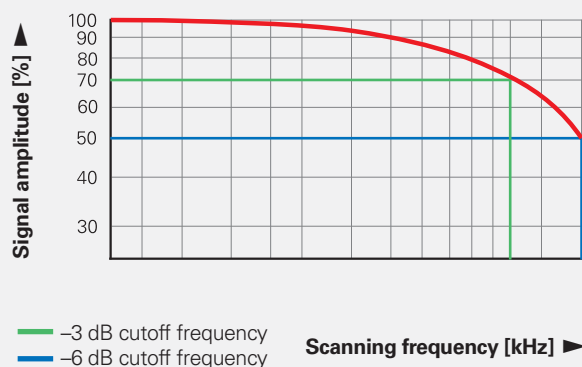

Input Circuitry of the Subsequent Electronics

Dimensioning

Operational amplifier MC 34074

$Z_0 = 120 \Omega$

$R_1 = 10 \text{ k}\Omega$ and $C_1 = 100 \text{ pF}$

$R_2 = 34.8 \text{ k}\Omega$ and $C_2 = 10 \text{ pF}$

$U_B = \pm 15 \text{ V}$

U_1 approx. U_0

-3 dB cutoff frequency of circuitry

Approx. 450 kHz

Approx. 50 kHz with $C_1 = 1000 \text{ pF}$
and $C_2 = 82 \text{ pF}$

The circuit variant for 50 kHz does reduce the bandwidth of the circuit, but in doing so it improves its noise immunity.

Circuit output signals

$U_a = 3.48 V_{PP}$ typically

Gain 3.48

Monitoring of the incremental signals

The following thresholds are recommended for monitoring of the signal level M:

Lower threshold: $0.30 V_{PP}$

Upper threshold: $1.35 V_{PP}$

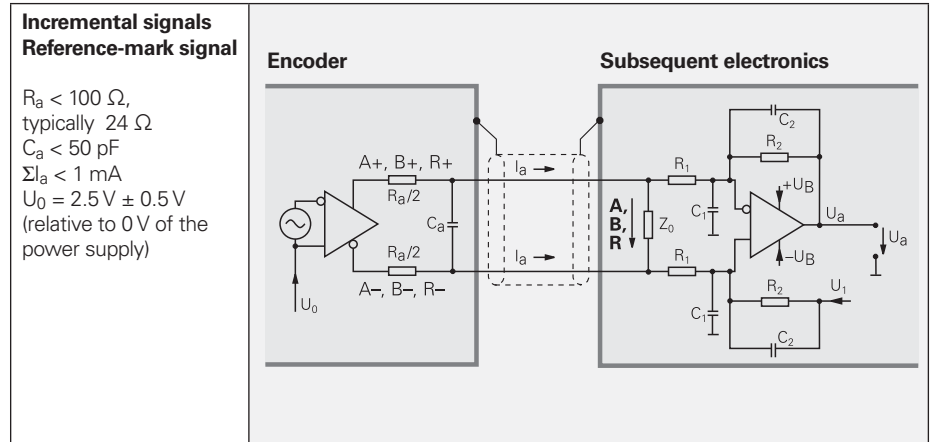

Pin Layout

12-pin coupling, M23		12-pin connector, M23				15-pin D-sub connector For ND 28x/PWM 20 or on encoder								
	Power supply				Incremental signals						Other signals			
	12	2	10	11	5	6	8	1	3	4	9	7	/	
	4	12	2	10	1	9	3	11	14	7	5/6/8/15	13	/	
	U_P	Sensor U_P	0V	Sensor 0V	A+	A-	B+	B-	R+	R-	Vacant	Vacant	Vacant	
	Brown/ Green	Blue	White/ Green	White	Brown	Green	Gray	Pink	Red	Black	/	Violet	Yellow	

Shield on housing; U_P = power supply voltage

Sensor: The sensor line is connected in the encoder with the corresponding power line.

Vacant pins or wires must not be used!

Color assignment applies only to extension cable.

Interfaces

Incremental Signals

HEIDENHAIN encoders with  interface incorporate electronics that digitize sinusoidal scanning signals with or without interpolation.

The **incremental signals** are transmitted as the square-wave pulse trains U_{a1} and U_{a2} , phase-shifted by 90° elec. The **reference mark signal** consists of one or more reference pulses U_{a0} , which are gated with the incremental signals. In addition, the integrated electronics produce their **inverted signals** $\overline{U_{a1}}$, $\overline{U_{a2}}$ and $\overline{U_{a0}}$ for noise-proof transmission. The illustrated sequence of output signals—with U_{a2} lagging U_{a1} —applies to the direction of motion shown in the dimension drawing.

The **fault-detection signal** $\overline{U_{aS}}$ indicates fault conditions such as breakage of the power line or failure of the light source. It can be used for such purposes as machine shut-off during automated production.

The distance between two successive edges of the incremental signals U_{a1} and U_{a2} through 1-fold, 2-fold or 4-fold evaluation is one **measuring step**.

The subsequent electronics must be designed to detect each edge of the square-wave pulse. The minimum **edge separation a** listed in the *Specifications* applies for the illustrated input circuitry with a cable length of 1 m, and refers to measurement at the output of the differential line receiver. Cable-dependent differences in the propagation times additionally reduce the edge separation by 0.2 ns per meter of cable. To prevent counting errors, design the subsequent electronics to process as little as 90 % of the resulting edge separation.

The max. permissible **shaft speed** or **traversing velocity** must never be exceeded.

The permissible **cable length** for transmission of the TTL square-wave signals to the subsequent electronics depends on the edge separation a . It is at most 100 m, or 50 m for the fault detection signal. This requires, however, that the power supply (see *Specifications*) be ensured at the encoder. The sensor lines can be used to measure the voltage at the encoder and, if required, correct it with an automatic control system (remote sense power supply).

Interface	Square-wave signals 
Incremental signals	2 square-wave signals U_{a1}, U_{a2} and their inverted signals $\overline{U_{a1}}$, $\overline{U_{a2}}$
Reference-mark signal Pulse width Delay time	1 or more TTL square-wave pulses U_{a0} and their inverted pulses $\overline{U_{a0}}$ 90° elec. (other widths available on request) $ t_d \leq 50$ ns
Fault-detection signal Pulse width	1 TTL square-wave pulse $\overline{U_{aS}}$ Improper function: LOW (upon request: U_{a1}/U_{a2} high impedance) Proper function: HIGH $t_s \geq 20$ ms
Signal amplitude	Differential line driver as per EIA standard RS-422 $U_H \geq 2.5$ V at $-I_H = 20$ mA ERN 1x23: 10 mA $U_L \leq 0.5$ V at $I_L = 20$ mA ERN 1x23: 10 mA
Permissible load	$Z_0 \geq 100 \Omega$ Between associated outputs $ I_L \leq 20$ mA Max. load per output (ERN 1x23: 10 mA) $C_{load} \leq 1000$ pF With respect to 0 V Outputs protected against short circuit to 0 V
Switching times (10% to 90%)	$t_+ / t_- \leq 30$ ns (typically 10 ns) with 1 m cable and recommended input circuitry
Connecting cable Cable length Propagation time	Shielded HEIDENHAIN cable PUR [$4(2 \times 0.14 \text{ mm}^2) + (4 \times 0.5 \text{ mm}^2)$] Max. 100 m ($\overline{U_{aS}}$ max. 50 m) at distributed capacitance 90 pF/m 6 ns/m

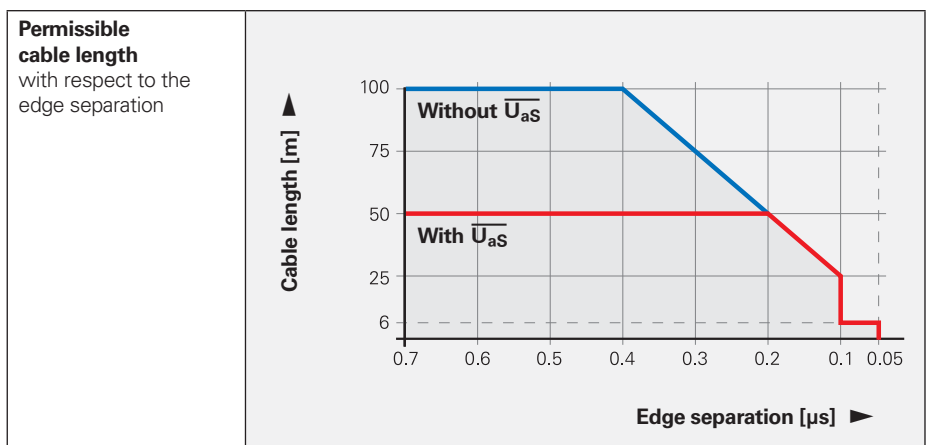
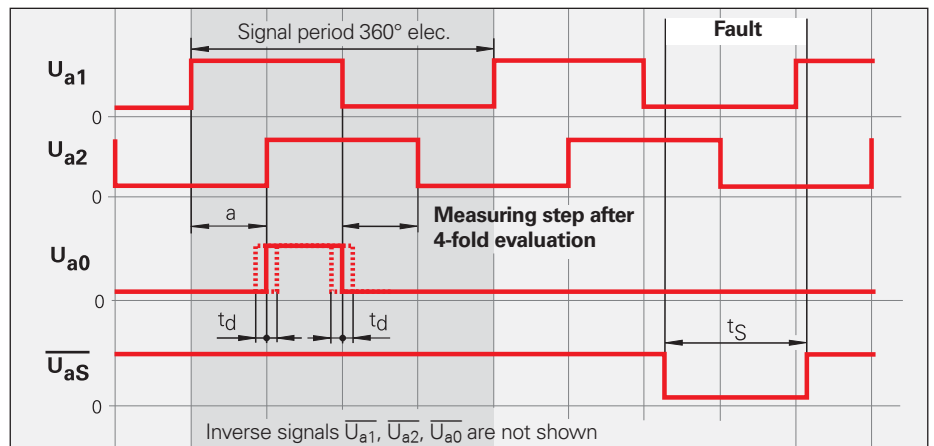

Input Circuitry of the Subsequent Electronics

Dimensioning

IC₁ = Recommended differential line receiver
 DS 26 C 32 AT
 Only for a > 0.1 μs:
 AM 26 LS 32
 MC 3486
 SN 75 ALS 193

R₁ = 4.7 kΩ





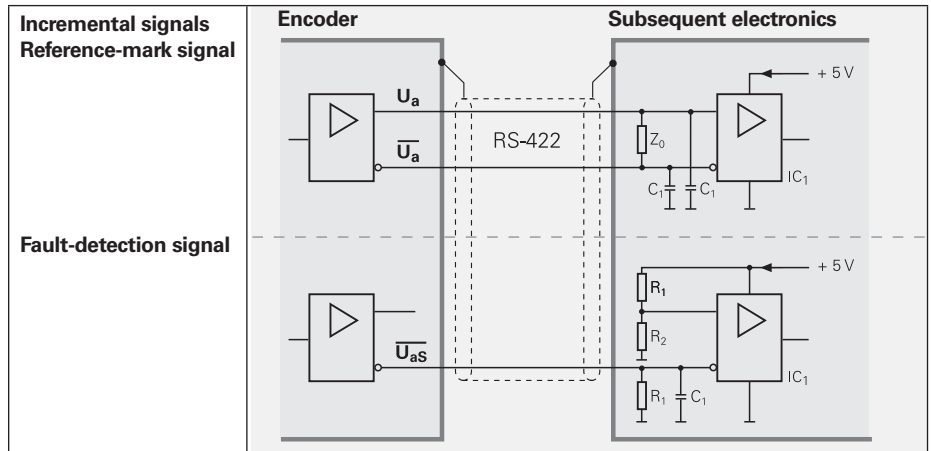

R₂ = 1.8 kΩ

Z₀ = 120 Ω

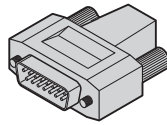
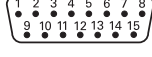
C₁ = 220 pF (serves to improve noise immunity)

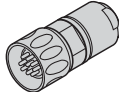

Pin Layout

15-pin D-sub connector					12-pin HEIDENHAIN connector								
  					  								
Power supply					Incremental signals						Other signals		
	12	2	10	11	5	6	8	1	3	4	7	/	9
	4	12	2	10	1	9	3	11	14	7	13	5/6/8	15
	U _P	Sensor U _P	0V	Sensor 0V	U _{a1}	U _{a1}	U _{a2}	U _{a2}	U _{a0}	U _{a0}	U _{aS} ¹⁾	Vacant	Vacant ²⁾
	Brown/Green	Blue	White/Green	White	Brown	Green	Gray	Pink	Red	Black	Violet	-	Yellow

Shield on housing; U_P = power supply voltage

Sensor: The sensor line is connected in the encoder with the corresponding power line.

¹⁾ ERO 14xx: Vacant

²⁾ Exposed linear encoders: Switchover TTL/11 μAPP for PWT

Vacant pins or wires must not be used!

Color assignment applies only to extension cable.

Interfaces

Absolute Position Values EnDat

The EnDat interface is a digital, **bidirectional** interface for encoders. It is capable both of transmitting **position values** as well as transmitting or updating information stored in the encoder, or saving new information. Thanks to the **serial transmission method**, only **four signal lines** are required. The data is transmitted in **synchronism** with the clock signal from the subsequent electronics. The type of transmission (position values, parameters, diagnostics, etc.) is selected through mode commands that the subsequent electronics send to the encoder. Some functions are available only with EnDat 2.2 mode commands.

For more information, refer to the *EnDat* Technical Information sheet or visit www.endat.de.

Position values can be transmitted with or without additional information (e.g. position value 2, temperature sensors, diagnostics, limit position signals).

Besides the position, additional information can be interrogated in the closed loop and functions can be performed with the EnDat 2.2 interface.

Parameters are saved in various memory areas, e.g.:

- Encoder-specific information
- Information of the OEM (e.g. "electronic ID label" of the motor)
- Operating parameters (datum shift, instruction, etc.)
- Operating status (alarm or warning messages)

Monitoring and diagnostic functions

of the EnDat interface make a detailed inspection of the encoder possible.

- Error messages
- Warnings
- Online diagnostics based on valuation numbers (EnDat 2.2)

Incremental signals

EnDat encoders are available with or without incremental signals. EnDat 21 and EnDat 22 encoders feature a high internal resolution. An evaluation of the incremental signal is therefore unnecessary.

Clock frequency and cable length

The clock frequency is variable—depending on the cable length (max. 150 m)—between **100 kHz and 2 MHz**. With propagation-delay compensation in the subsequent electronics, clock frequencies **up to 16 MHz** at cable lengths up to 100 m are possible (for other values see *Specifications*).

Interface	EnDat serial bidirectional
Data transfer	Absolute position values, parameters and additional information
Data input	Differential line receiver according to EIA standard RS 485 for the signals $\overline{\text{CLOCK}}$, $\overline{\text{CLOCK}}$, DATA and $\overline{\text{DATA}}$
Data output	Differential line driver according to EIA standard RS 485 for DATA and $\overline{\text{DATA}}$ signals.
Position values	Ascending during traverse in direction of arrow (see dimensions of the encoders)
Incremental signals	$\sim 1 V_{PP}$ (see <i>Incremental signals 1 V_{PP}</i>) depending on the unit

Ordering designation	Command set	Incremental signals	Power supply
EnDat 01	EnDat 2.1 or EnDat 2.2	With	See specifications of the encoder
EnDat 21		Without	
EnDat 02	EnDat 2.2	With	Expanded range 3.6 to 5.25 V DC or 14 V DC
EnDat 22	EnDat 2.2	Without	

Versions of the EnDat interface (bold print indicates standard versions)

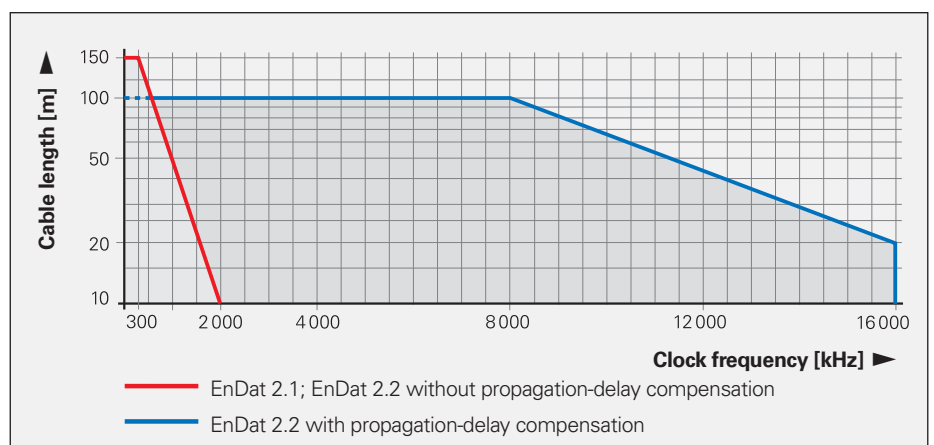
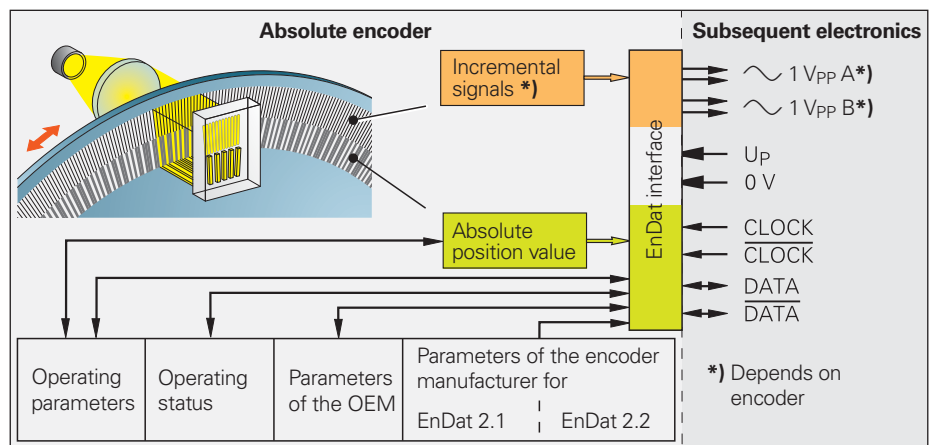

Input Circuitry of Subsequent Electronics





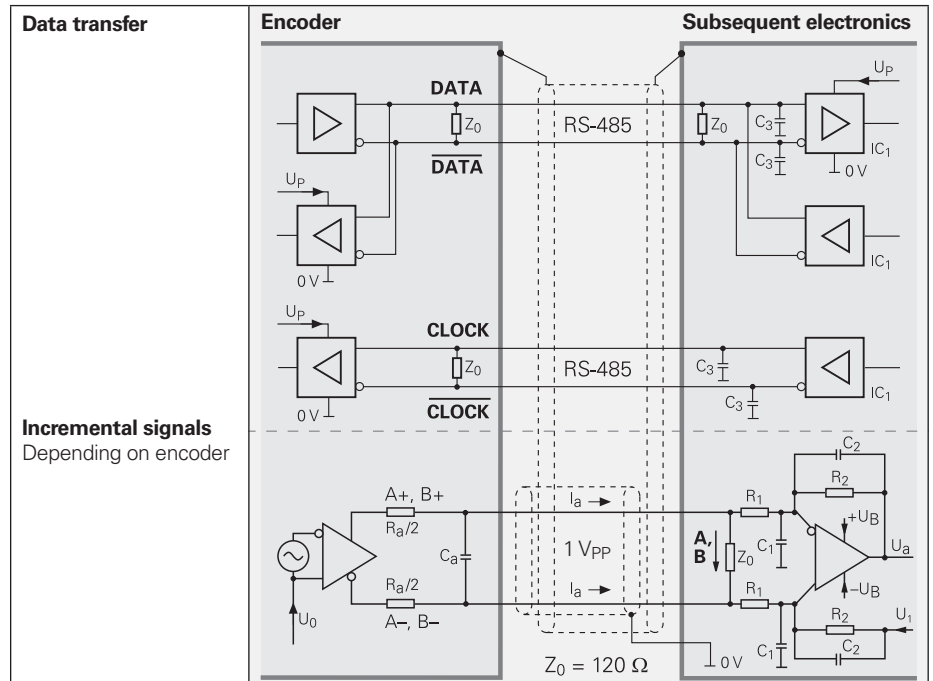

Dimensioning

IC₁ = RS 485 differential line receiver and driver

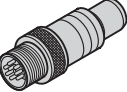
C₃ = 330 pF
Z₀ = 120 Ω

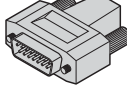
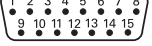

Pin Layout

8-pin coupling, M12				15-pin D-sub connector, male For IK215/PWM 20				
								
	Power supply			Absolute position values				
	8	2	5	1	3	4	7	6
	4	12	2	10	5	13	8	15
	U _P	Sensor U _P	0V	Sensor 0V	DATA	DATA	CLOCK	CLOCK
	Brown/Green	Blue	White/Green	White	Gray	Pink	Violet	Yellow

Cables and Connecting Elements

General Information

Connector (insulated): A connecting element with a coupling ring. Available with male or female contacts.

Symbols  

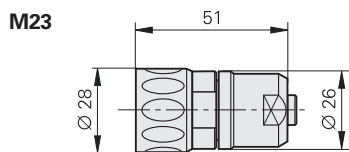

Coupling insulated: Connecting element with external thread; available with male or female contacts.

Symbols  

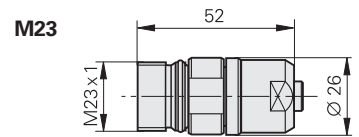

Mounted coupling with central fastening

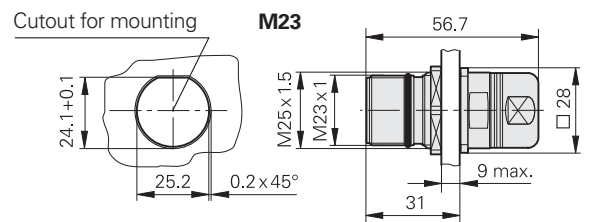

Mounted coupling with flange

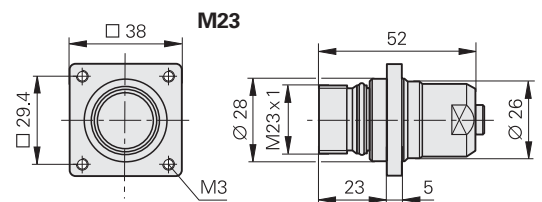

Flange socket: Permanently mounted on the encoder or a housing, with external thread (like a coupling), available with male or female contacts.

Symbols  

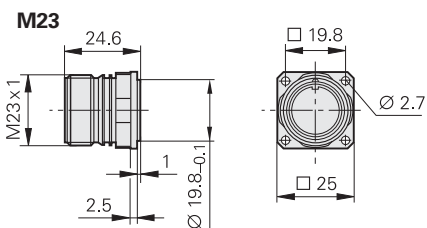

D-sub connector: for HEIDENHAIN controls, counters and IK absolute value cards

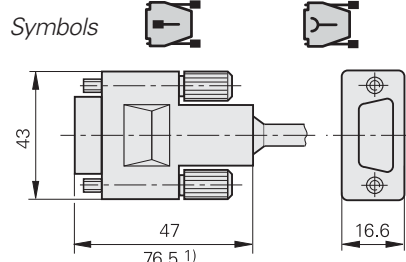

¹⁾ With integrated interpolation electronics

The pins on connectors are **numbered** in the direction opposite to those on couplings or flange sockets, regardless of whether the connecting elements are

male or  
female contacts.  





When engaged, the connections are **protected** to IP 67 (D-sub connector: IP 50; EN 60 529). When not engaged, there is no protection.





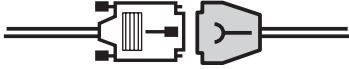
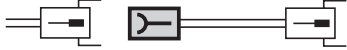
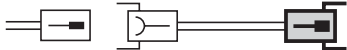
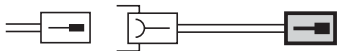

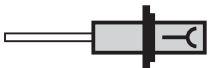
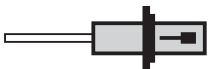
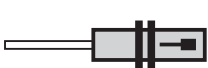

Accessories for flange sockets and M23 mounted couplings

Bell seal
ID 266526-01

Threaded metal dust cap
ID 219926-01







Connecting Elements

			15-pin	
Connector on connecting cable to connector on encoder cable	D-sub connector, female for cable \varnothing 8 mm 	315650-14		
			12-pin	9-pin
Mating element on connecting cable to connector on encoder cable	Coupling (female) for cable \varnothing 8 mm 	291698-02	291698-01	
Connector on connecting cable for connection to subsequent electronics	Connector (male) For cable with \varnothing 8 mm 	291697-08	291697-04	
Coupling on connecting cable	Coupling (male) for cable \varnothing 8 mm 	291698-04	291698-24	
Flange socket for mounting on subsequent electronics	Flange socket (female) 	315892-08	315892-06	
Mounted couplings	With flange (female) \varnothing 8 mm 	291698-07	291698-06	
	With flange (male) \varnothing 8 mm 	291698-31	-	
	With central fastener (male) \varnothing 6 to 10 mm 	741045-01	-	
Adapter \sim 1 V _{PP} /11 μ A _{PP} For converting the 1 V _{PP} signals to 11 μ A _{PP} ; 12-pin M23 connector (female) and 9-pin M23 connector (male)		364914-01	-	

		1 V _{PP} TTL	11 μA _{PP}	
PUR connecting cable [3(2 x 0.14 mm ²) + (2 x 1 mm ²)]				
PUR connecting cable [6(2 x 0.19 mm ²)]				
PUR connecting cable [4(2 x 0.14 mm ²) + (4 x 0.5 mm ²)]		Ø 8 mm	Ø 6 mm ¹⁾	Ø 8 mm
Complete with D-sub connector (female) and M23 connector (male)		331693-xx	355215-xx	–
With one D-sub connector (female), 15-pin		332433-xx	355209-xx	–
Complete with D-sub connector (female) and connector (male), 15-pin for ND 28x, EIB 741; only 1 V _{PP} : ND 11xx, ND 12xx		335074-xx	355186-xx	738681-xx
Complete with D-sub connector (female) and D-sub connector (female), 15-pin, for ND 780, PT 880, IK 220		335077-xx	349687-xx	–
Cable only		244957-01	291639-01	–
Complete with M23 coupling (female) and D-sub connector (male), 15-pin for ND 28x, EIB 741; only 1 V _{PP} : ND 11xx, ND 12xx		309784-xx	–	653231-xx
Complete with M23 coupling (female) and D-sub connector (male), 19-pin for ND 11xx, ND 12xx (not 1 V _{PP})		617513-xx	–	716905-xx
Complete with M23 coupling (female) and D-sub connector (female), 15-pin, for ND 780, PT 880, IK 220		309783-xx	–	368172-xx
With one connector with M23 coupling (female)		298402-xx	–	309780-xx
Complete with M23 coupling (female) and M23 connector (male)		298400-xx	–	309774-xx

¹⁾ Cable length max. 9 m

EnDat without incremental signals

PUR connecting cable [4 × 2 × 0.09 mm ²]		EnDat without incremental signals	
PUR connecting cable [(4 × 0.14 mm ²) + (4 × 0.34 mm ²)]		Ø 6 mm	Ø 3.7 mm
Complete with connector (female) and coupling (male)		368330-xx	801142-xx ¹⁾
Complete with right-angle connector (female) and coupling (male)		373289-xx	801149-xx ¹⁾
Complete with connector (female) and D-sub connector (female), 15-pin, for TNC (position inputs)		535627-xx	–
Complete with connector (female) and D-sub connector (male), 15-pin, for IK 215, PWM 20, EIB 741 etc.		524599-xx	801129-xx ¹⁾
Complete with right-angle connector (female) and D-sub connector (male), 15-pin, for IK 215, PWM 20, EIB 741 etc.		722025-xx	801140-xx ¹⁾
With one connector (female)		634265-xx	–
With one right-angle connector, (female)		606317-xx	–

¹⁾ Max. cable length 6 m

General Electrical Information

Power supply

Connect HEIDENHAIN encoders only to subsequent electronics whose power supply is generated from PELV systems (**EN 50178**). In addition, overcurrent protection and overvoltage protection are required in safety-related applications.

If HEIDENHAIN encoders are to be operated in accordance with IEC 61010-1, power must be supplied from a secondary circuit with current or power limitation as per IEC 61010-1:2001, section 9.3 or IEC 60950-1:2005, section 2.5 or a Class 2 secondary circuit as specified in UL1310.

The encoders require a **stabilized DC voltage U_p** as power supply. The respective *Specifications* state the required power supply and the current consumption. The permissible ripple content of the DC voltage is:

- High frequency interference
 $U_{PP} < 250 \text{ mV}$ with $dU/dt > 5 \text{ V}/\mu\text{s}$
- Low frequency fundamental ripple
 $U_{PP} < 100 \text{ mV}$

The values apply as measured at the encoder, i.e., without cable influences. The voltage can be monitored and adjusted with the encoder's **sensor lines**. If a controllable power supply is not available, the voltage drop can be halved by switching the sensor lines parallel to the corresponding power lines.

Calculation of the **voltage drop**:

$$\Delta U = 2 \cdot 10^{-3} \cdot \frac{1.05 \cdot L_C \cdot I}{56 \cdot A_p}$$

- where
- ΔU : Voltage drop in V
 - 1.05: Length factor due to twisted wires
 - L_C : Cable length in m
 - I : Current consumption in mA
 - A_p : Cross section of power lines in mm^2

The voltage actually applied to the encoder is to be considered when **calculating the encoder's power requirement**. This voltage consists of the supply voltage U_p provided by the subsequent electronics minus the line drop at the encoder. For encoders with an expanded supply range, the voltage drop in the power lines must be calculated under consideration of the nonlinear current consumption (see next page).

If the voltage drop is known, all parameters for the encoder and subsequent electronics can be calculated, e.g. voltage at the encoder, current requirements and power consumption of the encoder, as well as the power to be provided by the subsequent electronics.

Switch-on/off behavior of the encoders

The output signals are valid no sooner than after the switch-on time $t_{SOT} = 1.3 \text{ s}$ (2 s for PROFIBUS-DP) (see diagram). During the time t_{SOT} they can have any levels up to 5.5 V (with HTL encoders up to U_{Pmax}). If an interpolation electronics unit is inserted between the encoder and the power supply, this unit's switch-on/off characteristics must also be considered. If the power supply is switched off, or when the supply voltage falls below U_{min} , the output signals are also invalid. During restart, the signal

level must remain below 1 V for the time t_{SOT} before power on. These data apply to the encoders listed in the catalog—customer-specific interfaces are not included.

Encoders with new features and increased performance range may take longer to switch on (longer time t_{SOT}). If you are responsible for developing subsequent electronics, please contact HEIDENHAIN in good time.

Insulation

The encoder housings are isolated against internal circuits.

Rated surge voltage: 500 V (preferred value as per VDE 0110 Part 1, overvoltage category II, contamination level 2)

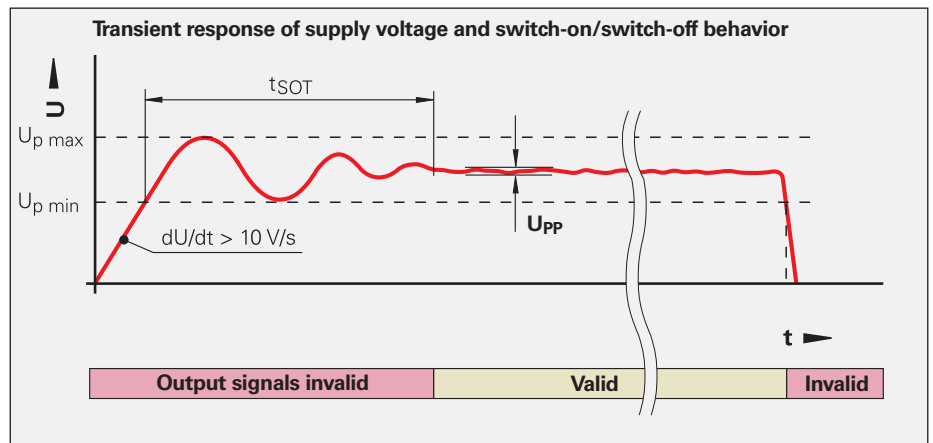

Cable	Cross section of power supply lines A_p			
	1 V _{PP} /TTL/HTL	11 μ A _{PP}	EnDat/SSI 17-pin	EnDat ⁵⁾ 8-pin
Ø 3.7 mm	0.05 mm ²	–	–	0.09 mm ²
Ø 4.3 mm	0.24 mm ²	–	–	–
Ø 4.5 mm EPG	0.05 mm ²	–	0.05 mm ²	0.09 mm ²
Ø 4.5 mm Ø 5.1 mm	0.14/0.09 ²⁾ mm ² 0.05 ^{2), 3)} mm ²	0.05 mm ²	0.05/0.14 ⁶⁾ mm ²	0.14 mm ²
Ø 5.5 mm PVC	0.1 mm ²	–	–	–
Ø 6 mm Ø 10 mm ¹⁾	0.19/0.14 ^{2), 4)} mm ²	–	0.08/0.19 ⁶⁾ mm ²	0.34 mm ²
Ø 8 mm Ø 14 mm ¹⁾	0.5 mm ²	1 mm ²	0.5 mm ²	1 mm ²

¹⁾ Metal armor
⁴⁾ LIDA 400

²⁾ Rotary encoders
⁵⁾ Also Fanuc, Mitsubishi

³⁾ Length gauges
⁶⁾ RCN, LC adapter cable

Encoders with expanded supply voltage range

For encoders with expanded supply voltage range, the current consumption has a nonlinear relationship with the supply voltage. On the other hand, the power consumption follows a linear curve (see *Current and power consumption* diagram). The maximum power consumption at minimum and maximum supply voltage is listed in the **Specifications**. The maximum power consumption (worst case) accounts for:

- Recommended receiver circuit
- Cable length 1 m
- Age and temperature influences
- Proper use of the encoder with respect to clock frequency and cycle time

The typical current consumption at no load (only supply voltage is connected) for 5 V supply is specified.

The actual power consumption of the encoder and the required power output of the subsequent electronics are measured, while taking the voltage drop on the supply lines into consideration, in four steps:

Step 1: Resistance of the supply lines

The resistance values of the supply lines (adapter cable and encoder cable) can be calculated with the following formula:

$$R_L = 2 \cdot \frac{1.05 \cdot L_C}{56 \cdot A_P}$$

Step 2: Coefficients for calculation of the drop in line voltage

$$b = -R_L \cdot \frac{P_{E_{max}} - P_{E_{min}}}{U_{E_{max}} - U_{E_{min}}} - U_P$$

$$c = P_{E_{min}} \cdot R_L + \frac{P_{E_{max}} - P_{E_{min}}}{U_{E_{max}} - U_{E_{min}}} \cdot R_L \cdot (U_P - U_{E_{min}})$$

Step 3: Voltage drop based on the coefficients b and c

$$\Delta U = -0.5 \cdot (b + \sqrt{b^2 - 4 \cdot c})$$

Where:

$U_{E_{max}}$,

$U_{E_{min}}$: Minimum or maximum supply voltage of the encoder in V

$P_{E_{min}}$,

$P_{E_{max}}$: Maximum power consumption at minimum or maximum power supply, respectively, in W

U_P : Supply voltage of the subsequent electronics in V

Step 4: Parameters for subsequent electronics and the encoder

Voltage at encoder:

$$U_E = U_P - \Delta U$$

Current requirement of encoder:

$$I_E = \Delta U / R_L$$

Power consumption of encoder:

$$P_E = U_E \cdot I_E$$

Power output of subsequent electronics:

$$P_S = U_P \cdot I_E$$

R_L : Cable resistance (for both directions) in ohms

ΔU : Voltage drop in the cable in V

1.05: Length factor due to twisted wires

L_C : Cable length in m

A_P : Cross section of power lines in mm^2

Influence of cable length on the power output of the subsequent electronics (example representation)

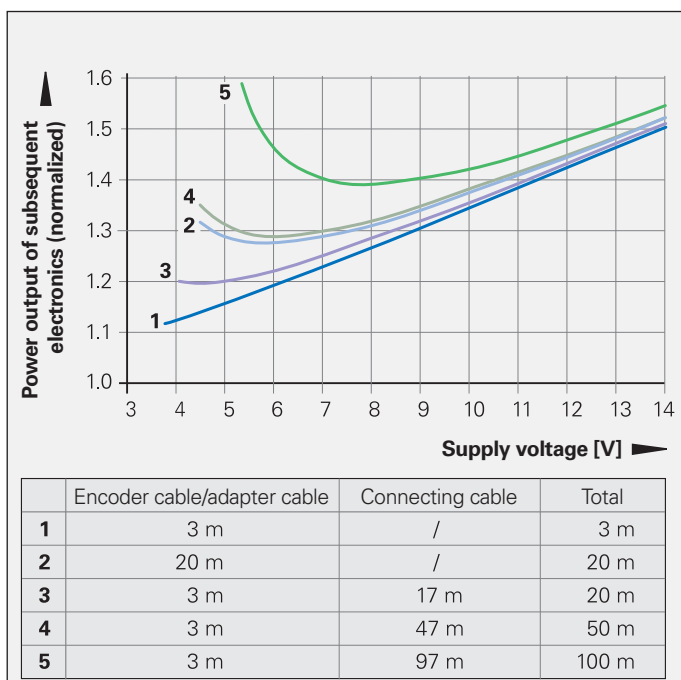

Current and power consumption with respect to the supply voltage (example representation)

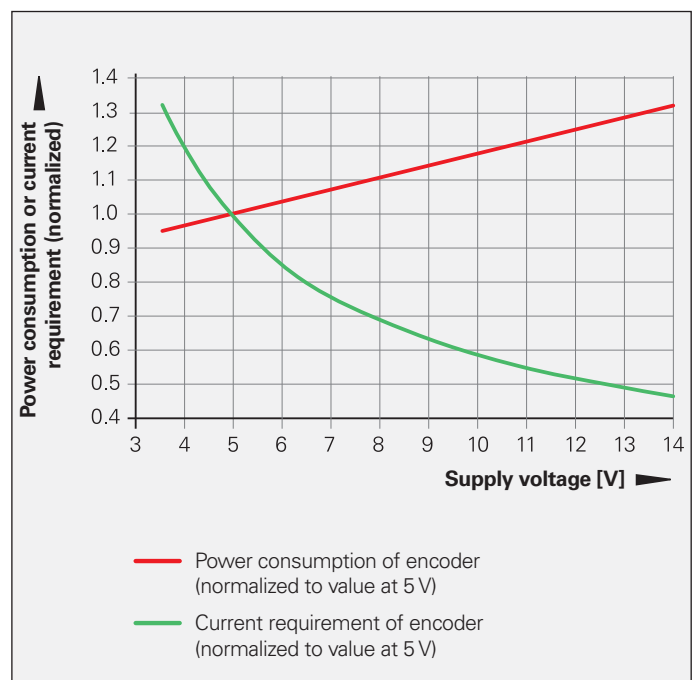

Electrically Permissible Speed/ Traversing Speed

The maximum permissible shaft speed or traversing velocity of an encoder is derived from

- the **mechanically** permissible shaft speed/traversing velocity (if listed in the *Specifications*) and
- the **electrically** permissible shaft speed/ traversing velocity.

For encoders with **sinusoidal output signals**, the electrically permissible shaft speed/traversing velocity is limited by the -3 dB/ -6 dB cutoff frequency or the permissible input frequency of the subsequent electronics.

For encoders with **square-wave signals**, the electrically permissible shaft speed/ traversing velocity is limited by

- the maximum permissible scanning/ output frequency f_{max} of the encoder, and
- the minimum permissible edge separation a for the subsequent electronics.

For angle or rotary encoders

$$n_{max} = \frac{f_{max}}{z} \cdot 60 \cdot 10^3$$

For linear encoders

$$v_{max} = f_{max} \cdot SP \cdot 60 \cdot 10^{-3}$$

Where:

- n_{max} : Elec. permissible speed in min^{-1}
- v_{max} : Elec. permissible traversing velocity in m/min
- f_{max} : Max. scanning/output frequency of encoder or input frequency of subsequent electronics in kHz
- z : Line count of the angle or rotary encoder per 360°
- SP : Signal period of the linear encoder in μm

Cable

For safety-related applications, use HEIDENHAIN cables and connectors.

Versions

The cables of almost all HEIDENHAIN encoders and all adapter and connecting cables are sheathed in **polyurethane (PUR cables)**. Many adapter cables for within motors and a few cables on encoders are sheathed in a **special elastomer (EPG)**. Many adapter cables within the motor consist of TPE wires (**special thermoplastic**) in braided sleeving. Individual encoders feature cable with a sleeve of **polyvinyl chloride (PVC)**. This cables are identified in the catalog as EPG, TPE or PVC.

Durability

PUR cables are resistant to oil in accordance with **VDE 0472** (Part 803/test type B) and to hydrolysis and microbes in accordance with **VDE 0282** (Part 10). They are free of PVC and silicone and comply with UL safety directives. The **UL certification** "AWM STYLE 20963 80 °C 30 V E63216" is documented on the cable.

EPG cables are resistant to oil in accordance with **VDE 0472** (Part 803/test type B) and to hydrolysis in accordance with **VDE 0282** (Part 10). They are free of silicone and halogens. In comparison with PUR cables, they are only somewhat resistant to media, frequent flexing and continuous torsion.

PVC cables are oil resistant. The UL certification "AWM E64638 STYLE20789 105C VW-1SC NIKKO" is documented on the cable.

TPE wires with braided sleeving are oil resistant and highly flexible.

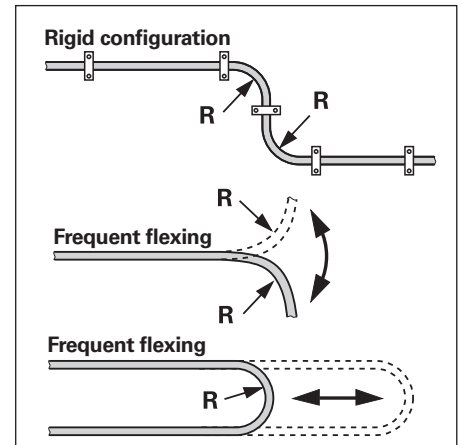

Temperature range

	Rigid configuration	Frequent flexing
PUR	-40 to 80 °C	-10 to 80 °C
EPG TPE	-40 to 120 °C	-
PVC	-20 to 90 °C	-10 to 90 °C

PUR cables with limited resistance to hydrolysis and microbes are rated for up to 100 °C. If needed, please ask for assistance from HEIDENHAIN Traunreut.

Lengths

The **cable lengths** listed in the *Specifications* apply only for HEIDENHAIN cables and the recommended input circuitry of subsequent electronics.

Cable	Bend radius R	
	Rigid configuration	Frequent flexing
Ø 3.7 mm	≥ 8 mm	≥ 40 mm
Ø 4.3 mm	≥ 10 mm	≥ 50 mm
Ø 4.5 mm EPG	≥ 18 mm	-
Ø 4.5 mm Ø 5.1 mm Ø 5.5 mm PVC	≥ 10 mm	≥ 50 mm
Ø 6 mm Ø 10 mm ¹⁾	≥ 20 mm ≥ 35 mm	≥ 75 mm ≥ 75 mm
Ø 8 mm Ø 14 mm ¹⁾	≥ 40 mm ≥ 100 mm	≥ 100 mm ≥ 100 mm

¹⁾ Metal armor

Noise-Free Signal Transmission

Electromagnetic compatibility/ CE-compliance

When properly installed, and when HEIDENHAIN connecting cables and cable assemblies are used, HEIDENHAIN encoders fulfill the requirements for electromagnetic compatibility according to 2004/108/EC with respect to the generic standards for:

• Noise immunity EN 61000-6-2:

Specifically:

- ESD EN 61 000-4-2
- Electromagnetic fields EN 61 000-4-3
- Burst EN 61 000-4-4
- Surge EN 61 000-4-5
- Conducted disturbances EN 61 000-4-6
- Power frequency magnetic fields EN 61 000-4-8
- Pulse magnetic fields EN 61 000-4-9

• Interference EN 61000-6-4:

Specifically:

- For industrial, scientific and medical equipment (ISM) EN 55 011
- For information technology equipment EN 55 022

Transmission of measuring signals— electrical noise immunity

Noise voltages arise mainly through capacitive or inductive transfer. Electrical noise can be introduced into the system over signal lines and input or output terminals.

Possible sources of noise include:

- Strong magnetic fields from transformers, brakes and electric motors
- Relays, contactors and solenoid valves
- High-frequency equipment, pulse devices, and stray magnetic fields from switch-mode power supplies
- AC power lines and supply lines to the above devices

Protection against electrical noise

The following measures must be taken to ensure disturbance-free operation:

- Use only original HEIDENHAIN cables. Consider the voltage drop on supply lines.
- Use connecting elements (such as connectors or terminal boxes) with metal housings. Only the signals and power supply of the connected encoder may be routed through these elements. Applications in which additional signals are sent through the connecting element require specific measures regarding electrical safety and EMC.

- Connect the housings of the encoder, connecting elements and subsequent electronics through the shield of the cable. Ensure that the shield has complete contact over the entire surface (360°). For encoders with more than one electrical connection, refer to the documentation for the respective product.
- For cables with multiple shields, the inner shields must be routed separately from the outer shield. Connect the inner shield to 0V of the subsequent electronics. Do not connect the inner shields with the outer shield, neither in the encoder nor in the cable.
- Connect the shield to protective ground as per the mounting instructions.
- Prevent contact of the shield (e.g. connector housing) with other metal surfaces. Pay attention to this when installing cables.
- Do not install signal cables in the direct vicinity of interference sources (inductive consumers such as contactors, motors, frequency inverters, solenoids, etc.).
 - Sufficient decoupling from interference-signal-conducting cables can usually be achieved by an air clearance of 100 mm or, when cables are in metal ducts, by a grounded partition.
 - A minimum spacing of 200 mm to inductors in switch-mode power supplies is required.
- If compensating currents are to be expected within the overall system, a separate equipotential bonding conductor must be provided. The shield does not have the function of an equipotential bonding conductor.
- Provide power only from PELV systems (**EN 50 178**) to position encoders. Provide high-frequency grounding with low impedance (**EN 60204-1 Chap. EMC**).
- For encoders with 11 μA_{PP} interface: For extension cables, use only HEIDENHAIN cable ID 244955-01. Overall length: max. 30 m.

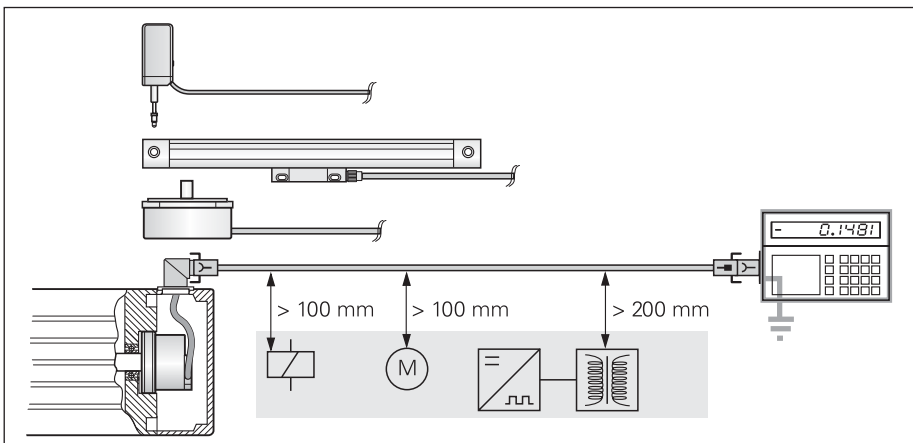

Minimum distance from sources of interference

HEIDENHAIN

DR. JOHANNES HEIDENHAIN GmbH

Dr.-Johannes-Heidenhain-Straße 5

83301 Traunreut, Germany

☎ +49 8669 31-0

FAX +49 8669 5061

E-mail: info@heidenhain.de

www.heidenhain.de

Vollständige und weitere Adressen siehe www.heidenhain.de
For complete and further addresses see www.heidenhain.de

DE	HEIDENHAIN Vertrieb Deutschland 83301 Traunreut, Deutschland ☎ 08669 31-3132 FAX 08669 32-3132 E-Mail: hd@heidenhain.de	DK	TPTEKNIK A/S 2670 Greve, Denmark www.tp-gruppen.dk	NO	HEIDENHAIN Scandinavia AB 7300 Orkanger, Norway www.heidenhain.no
	HEIDENHAIN Technisches Büro Nord 12681 Berlin, Deutschland ☎ 030 54705-240	ES	FARRESA ELECTRONICA S.A. 08028 Barcelona, Spain www.farresa.es	PH	Machinebanks Corporation Quezon City, Philippines 1113 E-mail: info@machinebanks.com
	HEIDENHAIN Technisches Büro Mitte 08468 Heinsdorfergrund, Deutschland ☎ 03765 69544	FI	HEIDENHAIN Scandinavia AB 02770 Espoo, Finland www.heidenhain.fi	PL	APS 02-489 Warszawa, Poland www.apserwis.com.pl
	HEIDENHAIN Technisches Büro West 44379 Dortmund, Deutschland ☎ 0231 618083-0	FR	HEIDENHAIN FRANCE sarl 92310 Sèvres, France www.heidenhain.fr	PT	FARRESA ELECTRÓNICA, LDA. 4470 - 177 Maia, Portugal www.farresa.pt
	HEIDENHAIN Technisches Büro Südwest 70771 Leinfelden-Echterdingen, Deutschland ☎ 0711 993395-0	GB	HEIDENHAIN (G.B.) Limited Burgess Hill RH15 9RD, United Kingdom www.heidenhain.co.uk	RO	HEIDENHAIN Reprezentantă Romania Braşov, 500338, Romania www.heidenhain.ro
	HEIDENHAIN Technisches Büro Südost 83301 Traunreut, Deutschland ☎ 08669 31-1345	GR	MB Milionis Vassilis 17341 Athens, Greece www.heidenhain.gr	RS	Serbia → BG
		HK	HEIDENHAIN LTD Kowloon, Hong Kong E-mail: sales@heidenhain.com.hk	RU	OOO HEIDENHAIN 125315 Moscow, Russia www.heidenhain.ru
AR	NAKASE SRL. B1653AOX Villa Ballester, Argentina www.heidenhain.com.ar	HR	Croatia → SL	SE	HEIDENHAIN Scandinavia AB 12739 Skärholmen, Sweden www.heidenhain.se
AT	HEIDENHAIN Techn. Büro Österreich 83301 Traunreut, Germany www.heidenhain.de	HU	HEIDENHAIN Kereskedelmi Képviselet 1239 Budapest, Hungary www.heidenhain.hu	SG	HEIDENHAIN PACIFIC PTE LTD. Singapore 408593 www.heidenhain.com.sg
AU	FCR Motion Technology Pty. Ltd Laverton North 3026, Australia E-mail: vicsales@fcrmotion.com	ID	PT Servitama Era Toolsindo Jakarta 13930, Indonesia E-mail: ptset@group.gts.co.id	SK	KOPRETINA TN s.r.o. 91101 Trencin, Slovakia www.kopretina.sk
BA	Bosnia and Herzegovina → SL	IL	NEUMO VARGUS MARKETING LTD. Tel Aviv 61570, Israel E-mail: neumo@neumo-vargus.co.il	SL	Posredništvo HEIDENHAIN NAVO d.o.o. 2000 Maribor, Slovenia www.heidenhain-hubl.si
BE	HEIDENHAIN NV/SA 1760 Roosdaal, Belgium www.heidenhain.be	IN	HEIDENHAIN Optics & Electronics India Private Limited Chetpet, Chennai 600 031, India www.heidenhain.in	TH	HEIDENHAIN (THAILAND) LTD Bangkok 10250, Thailand www.heidenhain.co.th
BG	ESD Bulgaria Ltd. Sofia 1172, Bulgaria www.esd.bg	IT	HEIDENHAIN ITALIANA S.r.l. 20128 Milano, Italy www.heidenhain.it	TR	T&M Mühendislik San. ve Tic. LTD. ŞTİ. 34728 Ümraniye-Istanbul, Turkey www.heidenhain.com.tr
BR	DIADUR Indústria e Comércio Ltda. 04763-070 – São Paulo – SP, Brazil www.heidenhain.com.br	JP	HEIDENHAIN K.K. Tokyo 102-0083, Japan www.heidenhain.co.jp	TW	HEIDENHAIN Co., Ltd. Taichung 40768, Taiwan R.O.C. www.heidenhain.com.tw
BY	Belarus GERTNER Service GmbH 50354 Huerth, Germany www.gertnergroup.com	KR	HEIDENHAIN Korea LTD. Gasan-Dong, Seoul, Korea 153-782 www.heidenhain.co.kr	UA	Gertner Service GmbH Büro Kiev 01133 Kiev, Ukraine www.gertnergroup.com
CA	HEIDENHAIN CORPORATION Mississauga, Ontario L5T2N2, Canada www.heidenhain.com	ME	Montenegro → SL	US	HEIDENHAIN CORPORATION Schaumburg, IL 60173-5337, USA www.heidenhain.com
CH	HEIDENHAIN (SCHWEIZ) AG 8603 Schwerzenbach, Switzerland www.heidenhain.ch	MK	Macedonia → BG	VE	Maquinaria Diekmann S.A. Caracas, 1040-A, Venezuela E-mail: purchase@diekmann.com.ve
CN	DR. JOHANNES HEIDENHAIN (CHINA) Co., Ltd. Beijing 101312, China www.heidenhain.com.cn	MX	HEIDENHAIN CORPORATION MEXICO 20235 Aguascalientes, Ags., Mexico E-mail: info@heidenhain.com	VN	AMS Co. Ltd HCM City, Vietnam E-mail: davidgoh@amsvn.com
CZ	HEIDENHAIN s.r.o. 102 00 Praha 10, Czech Republic www.heidenhain.cz	MY	ISOSERVE Sdn. Bhd 56100 Kuala Lumpur, Malaysia E-mail: isoserve@po.jaring.my	ZA	MAFEMA SALES SERVICES C.C. Midrand 1685, South Africa www.heidenhain.co.za
		NL	HEIDENHAIN NEDERLAND B.V. 6716 BM Ede, Netherlands www.heidenhain.nl		

